

Variable Speed Booster Sets

With Easymat & IMAT Control



EASYMAT SETS

General:

A range of economically priced variable speed cold water booster sets with one, two and three pump options. The sets feature the Easymat variable speed controller with either our all stainless steel MXH series or MXV-B series multi-stage pumps

Pumps:

MXH Series all stainless steel, horizontal, multi-stage centrifugal pumps. WRAs Approved
MXV-B Series all stainless steel vertical, multi-stage centrifugal pumps. WRAs approved

Motors:

Aluminium 2-Pole (2900 rpm) induction motors, three phase, 230/400/3/50, class F insulation, IP54 enclosure.

System:

One piece stainless steel manifolds and pipe-work, stainless steel fittings, nickel plated brass isolating and stainless steel non-return valves, electro-galvanised base plate, GWS PressureWave© accumulator. Fully wired and tested.

Operating Conditions:

Fluid:	Clean Cold Water.	Control:	Easymat variable speed controller via pressure transducer.
Fluid Temp:	Max 25 Deg.C.	Max Press:	10 bar Operational Pressure
Air Amb:	Max 40 Deg.C	Rated:	Continuous Service



Approval Number 1605304



Approval Number 1404327

FEATURES

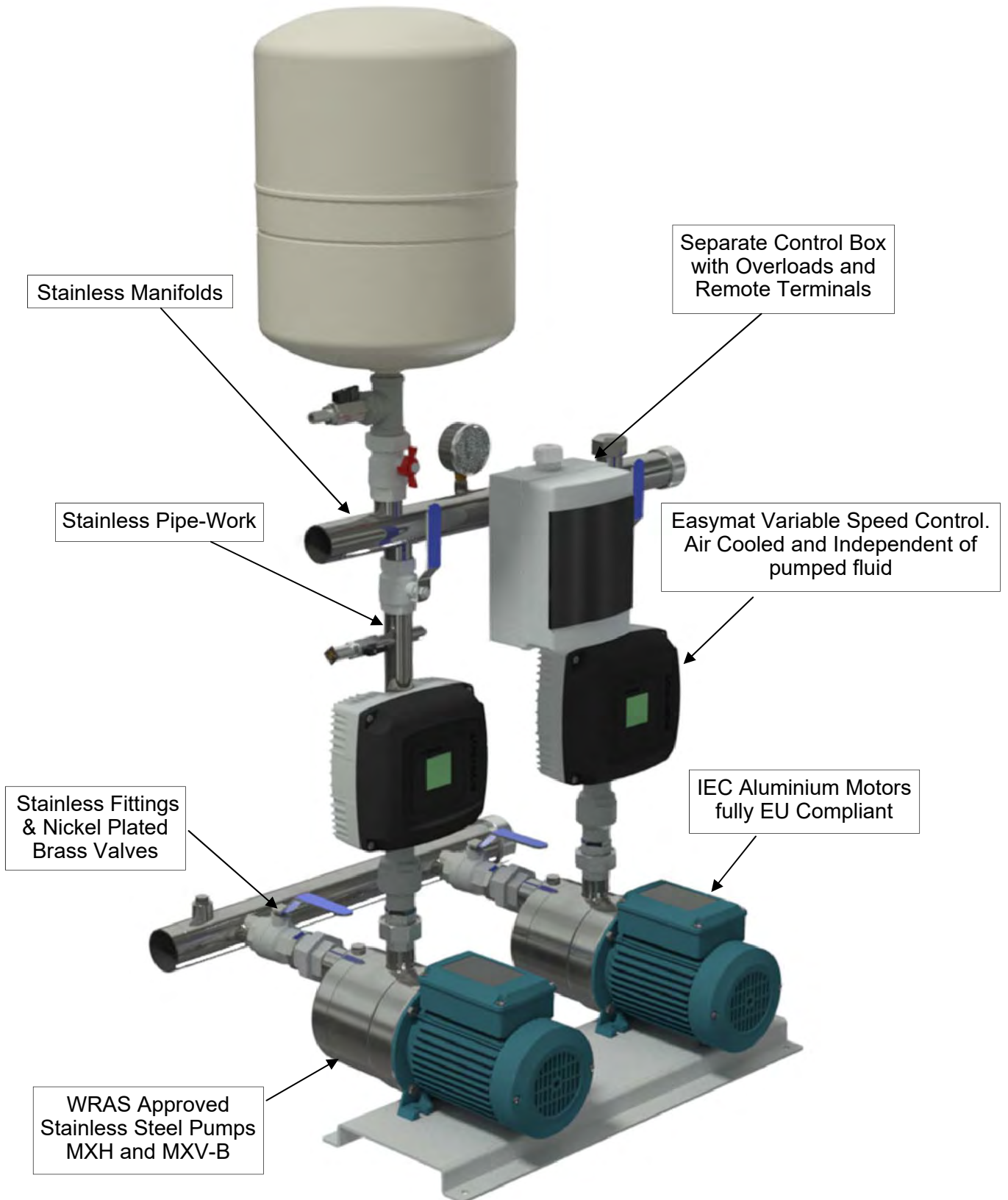

EASYMAT CONTROL

Control Panel

The Easymat is equipped with a control panel for simple system programming and parameter monitoring.

The 2 scroll buttons are used to scroll through the different operating parameters the Easymat can display.

At the same time you can use the 2 scroll buttons to move around the set up menu and to change the various options.

The custom LCD display gives a clear overview of the system condition and operating parameters. The icons above and below the display confirm the mode in which the Easymat is working and highlight any problems.

The 4 set-up buttons allow the operator to move between the set-up menus and to start and stop the pump/s. The symbols are designed to make the various function of each button clear. With these 4 buttons and the two scroll buttons you can manage all the set-up and operating parameters without the use of an external controller or computer.



LCD Display

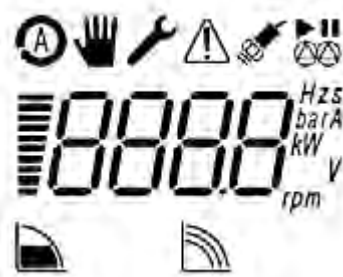

The integrated LCD custom display gives you an easy overview of the system condition and operating parameters.



Display Area. The display area shows the status of the parameters of the pump/s

The **Operating Icons** show in which mode the system is operating.



Constant pressure mode.

The system keeps the pressure constant as the demand for water changes. The user can choose the operating pressure as required.



Fixed speed mode.

The system works at a fixed speed which can be determined by the user as required.

The **System Icons** show in which way the system is operating.



Auto mode.

The icon shows that the system is operating in auto mode (constant pressure). The constant pressure icon will be shown on the lower section of the display.



Manual mode.

The icon shows that the system is operating in manual mode (fixed speed). With the navigation buttons the user can change the speed. The fixed speed icon will be shown on the lower section of the display.



Set-up mode.

The icon shows that the set-up menu is activated, in this mode it is possible to change all the operating parameters of the Easymat. Using the navigation buttons it is possible to scroll through the parameters and change them as required.



Sensor state.

This indicates the state of the pressure transducer connected to the Easymat. When lit it indicates that the transducer is working correctly, if flashing it indicates a transducer fault or incorrect connection.



Alarm.

This indicates that there is a fault on the system. A corresponding error number will be shown on the display.



Cascade mode.

This indicates that the multi-pump mode (max 2 pumps) is operating. The upper icon displays if the pump connected with the inverter is running or is in stand-by. The lower icon when lit indicates if the pump is the master unit or slave unit when flashing.

DIMENSIONS

easymat single pump variable speed booster set with MXH pump

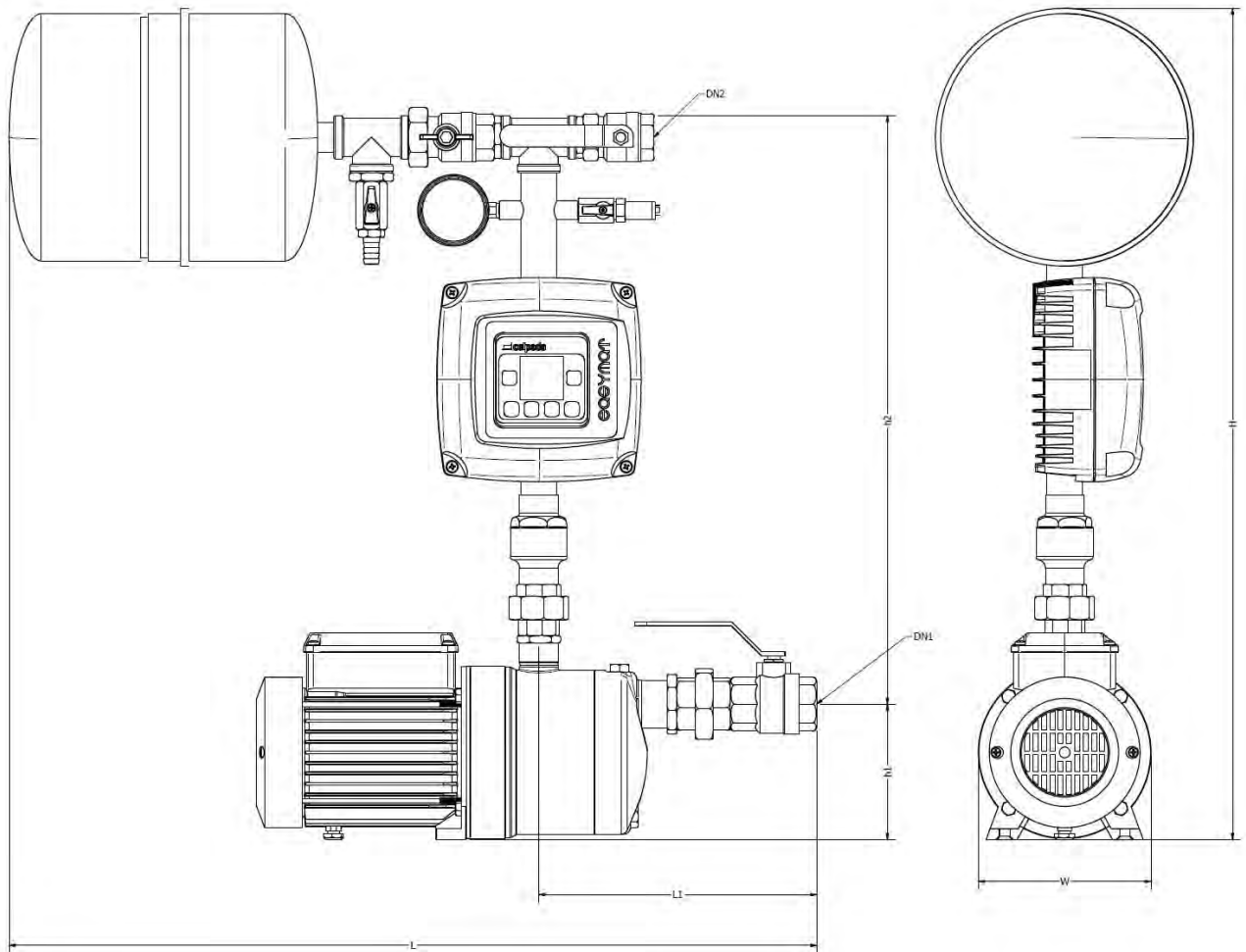

Model Number	DN1	DN2	mm					
			H	W	L	L1	h1	h2
1MXH202E-EMT-8	G1-1/4"	G1"	800	160	850	240	127	535
1MXH203E-EMT-8			800	160	850	240	127	535
1MXH204/A-EMT-8			800	160	910	265	127	535
1MXH205/A-EMT-8			800	160	830	290	127	535
1MXH206/B-EMT-8			800	160	1020	315	127	535
1MXH402E-EMT-8			800	160	850	240	127	535
1MXH403/A-EMT-8			800	160	875	240	127	535
1MXH404/A-EMT-8			800	160	910	265	127	535
1MXH405/B-EMT-8			800	160	995	290	127	535
1MXH406-EMT-8			800	160	1020	315	127	535
1MXH802/A-EMT-8	G1-1/2"	G1"	800	160	895	280	127	535
1MXH803-EMT-8			800	160	965	280	127	535
1MXH804-EMT-8			800	160	995	310	127	535
1MXH805/A-EMT-8			800	160	1065	340	127	535
1MXH1602-EMT-8	G2"	G1-1/2"	865	190	915	310	117	605
1MXH1603/A-EMT-8			865	190	955	310	117	605

Note:

Dimensions stated are Pre Production. Allow tolerance of 5%.

DIMENSIONS

easymat twin pump variable speed booster set with MXH pump

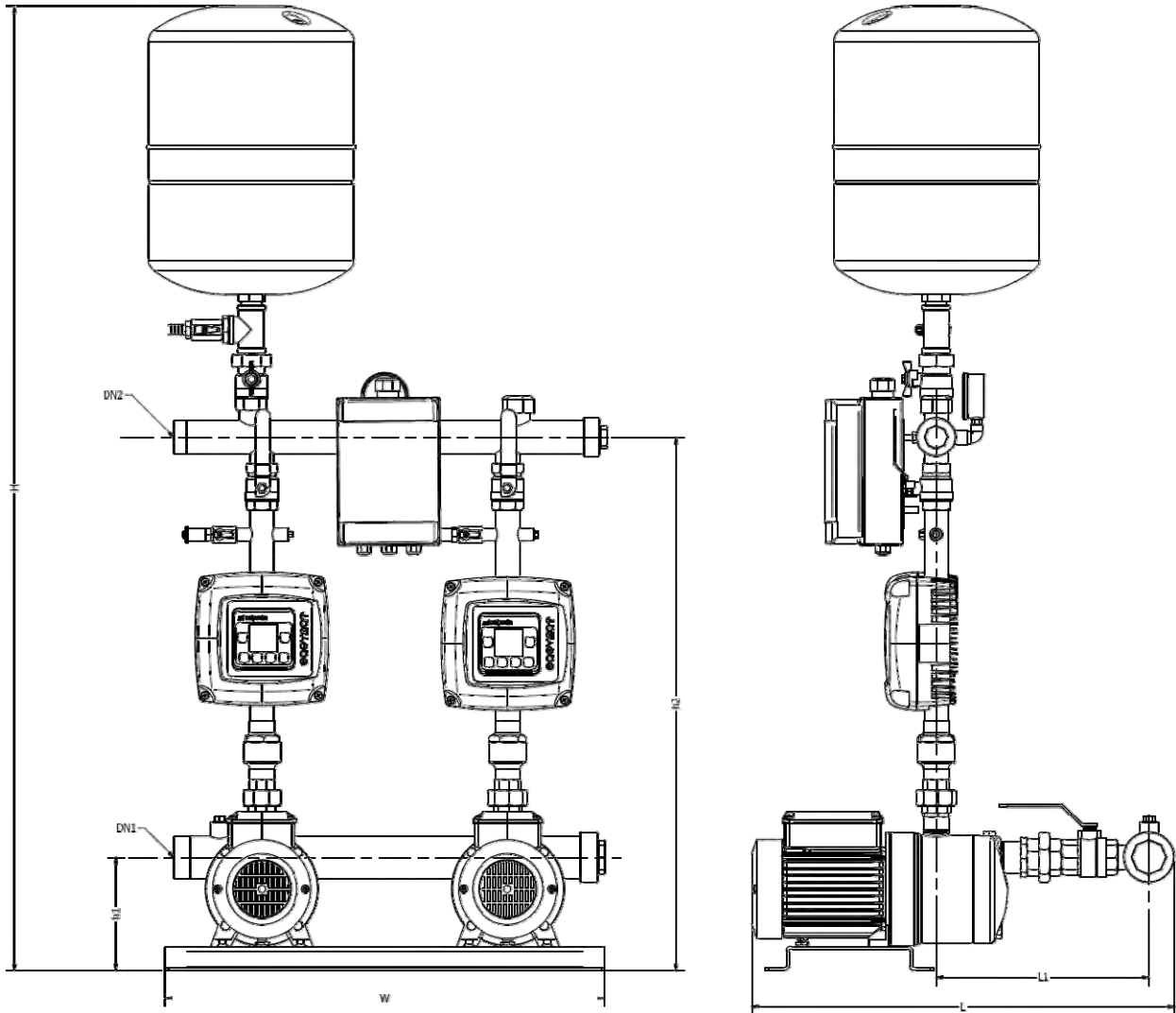

Model Number	DN1	DN2	mm					
			H	W	L	L1	h1	h2
2MXH202E-EMT-24	G2"	G1-1/2"	1425	625	565	305	160	785
2MXH203E-EMT-24			1425	625	565	305	160	785
2MXH204/A-EMT-24			1425	625	615	330	160	785
2MXH205/A-EMT-24			1425	625	640	355	160	785
2MXH206/B-EMT-24			1425	625	735	380	160	785
2MXH402E-EMT-24			1425	625	556	305	160	785
2MXH403/A-EMT-24			1425	625	590	305	160	785
2MXH404/A-EMT-24			1425	625	615	325	160	785
2MXH405/B-EMT-24			1425	625	710	355	160	785
2MXH406-EMT-24			1425	625	735	370	160	785
2MXH802/A-EMT-24	G2-1/2"	G2"	1430	625	620	340	160	785
2MXH803-EMT-24			1430	625	690	370	160	785
2MXH804-EMT-24			1430	625	720	390	160	785
2MXH805/A-EMT-24			1430	625	790	415	160	785
2MXH1602-EMT-24	G3"	G2-1/2"	1525	625	790	395	150	880
2MXH1603/A-EMT-24			1525	625	830	395	150	880

Note:
Dimensions stated are Pre Production. Allow tolerance of 5%.

DIMENSIONS

easymat three pump variable speed booster set with MXH pump

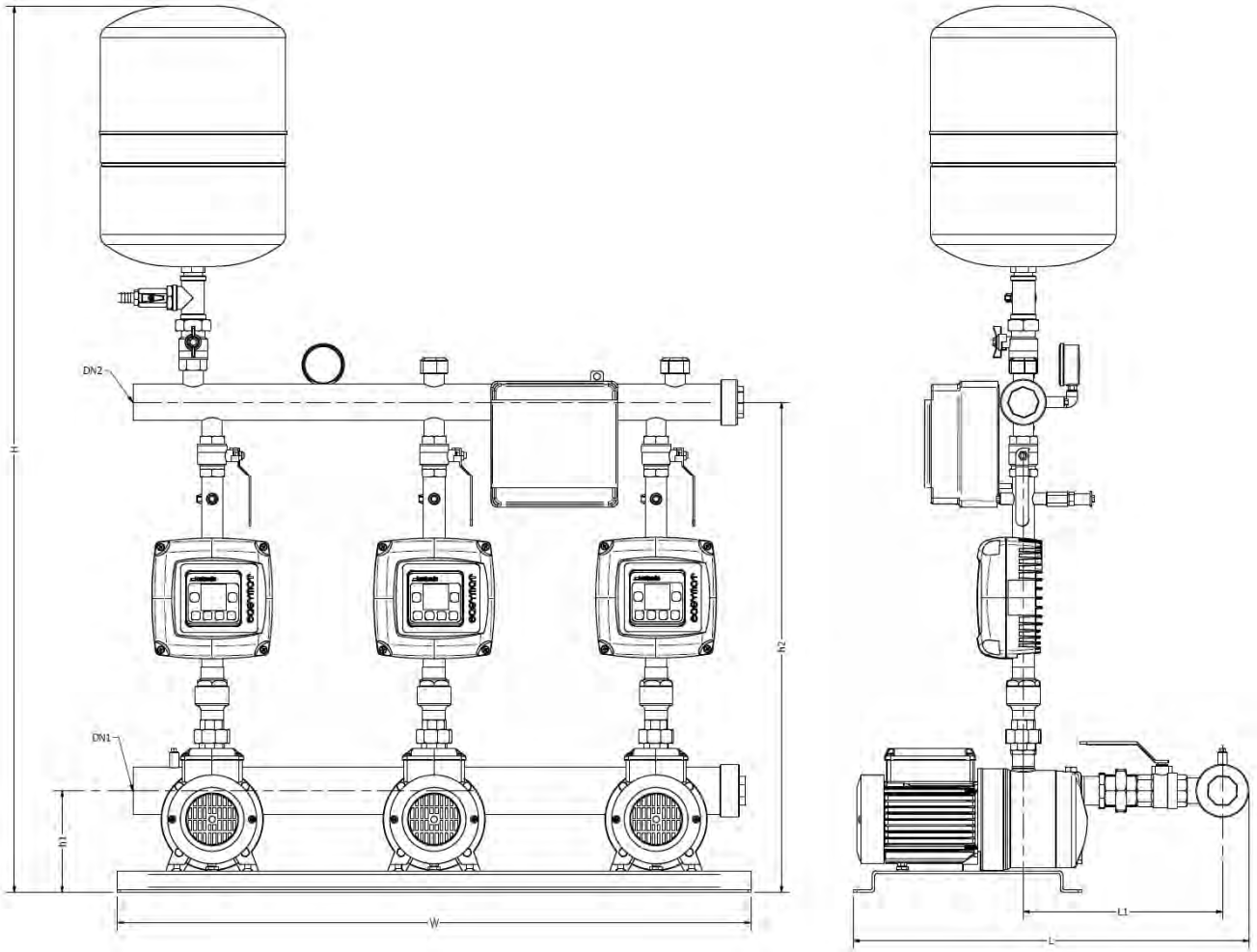

Model Number	DN1	DN2	mm					
			H	W	L	L1	h1	h2
3MXH202E-EMT-24	G2-1/2"	G2"	1440	1000	580	300	180	800
3MXH203E-EMT-24			1440	1000	580	300	180	800
3MXH204/A-EMT-24			1440	1000	630	325	180	800
3MXH205/A-EMT-24			1440	1000	655	350	180	800
3MXH206/B-EMT-24			1440	1000	725	375	180	800
3MXH402E-EMT-24			1440	1000	580	300	180	800
3MXH403/A-EMT-24			1440	1000	605	300	180	800
3MXH404/A-EMT-24			1440	1000	630	325	180	800
3MXH405/B-EMT-24			1440	1000	725	355	180	800
3MXH406-EMT-24			1440	1000	750	370	180	800
3MXH802/A-EMT-24	G3"	G2-1/2"	1490	1000	685	340	180	835
3MXH803-EMT-24			1490	1000	755	370	180	835
3MXH804-EMT-24			1490	1000	785	390	180	835
3MXH805/A-EMT-24			1490	1000	855	430	180	835
3MXH1602-EMT-24	DN100	DN80	1580	1000	790	380	180	895
3MXH1603/A-EMT-24			1580	1000	830	380	180	895

Note:
Dimensions stated are Pre Production. Allow tolerance of 5%.

DIMENSIONS

easymat single pump variable speed booster set with MXV-B pump

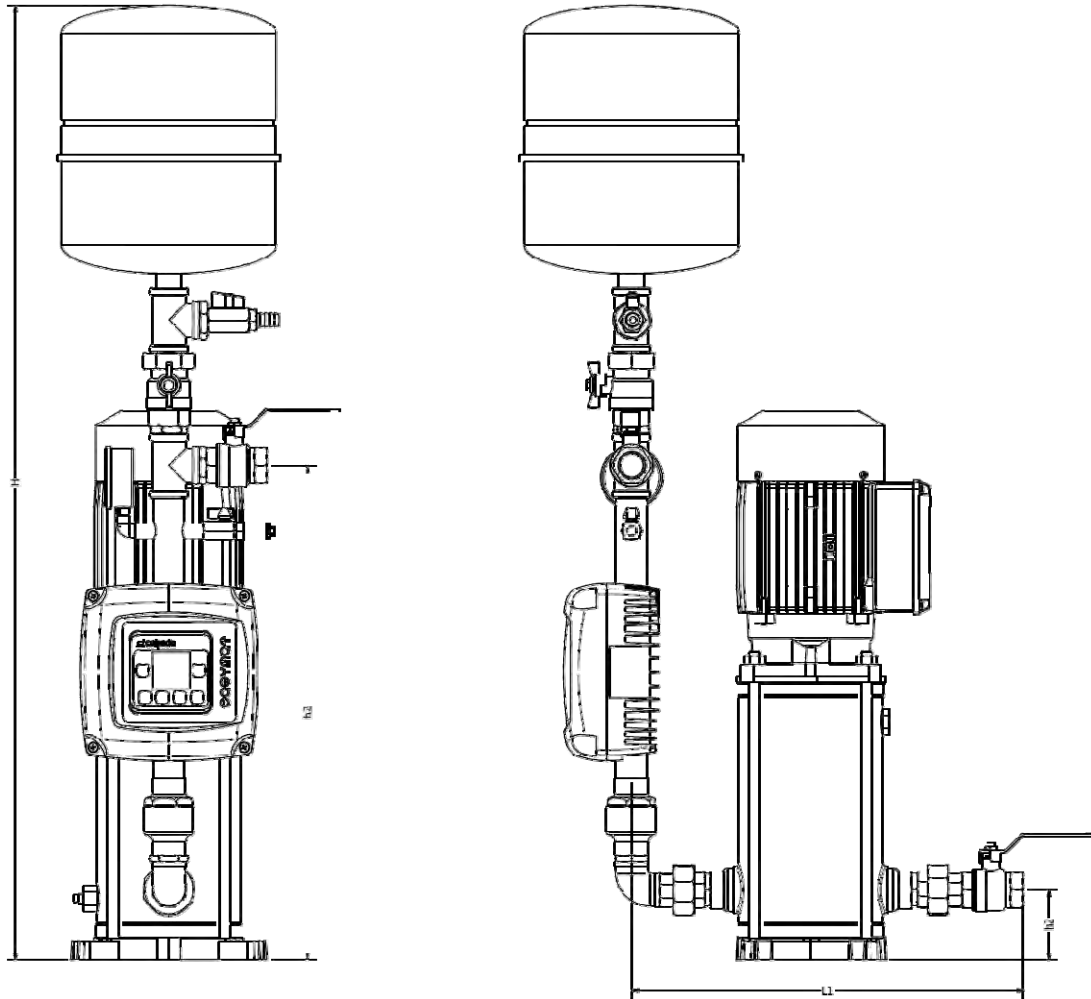

Model Number	DN1	DN2	mm			
			H	L1	h1	h2
1MXV-B25-204-EMT-8	G1"	G1"	1060	450	75	550
1MXV-B25-205-EMT-8			1060	450	75	550
1MXV-B25-206-EMT-8			1060	450	75	550
1MXV-B25-207-EMT-8			1060	450	75	550
1MXV-B25-208-EMT-8			1060	450	75	550
1MXV-B25-210-EMT-8			1060	450	75	550
1MXV-B32-404-EMT-8	G1-1/4"	G1-1/4"	1170	485	75	655
1MXV-B32-405-EMT-8			1170	485	75	655
1MXV-B32-406-EMT-8			1170	485	75	655
1MXV-B32-407-EMT-8			1170	485	75	655
1MXV-B32-408-EMT-8			1170	485	75	655
1MXV-B32-410-EMT-8			1170	485	75	655
1MXV-B40-804-EMT-8	G1-1/2"	G1-1/2"	1245	530	80	605
1MXV-B40-805-EMT-8			1245	530	80	605
1MXV-B40-806-EMT-8			1245	530	80	605

Note:
Dimensions stated are Pre Production. Allow tolerance of 5%.

DIMENSIONS

easymat twin pump variable speed booster set with MXV-B pump

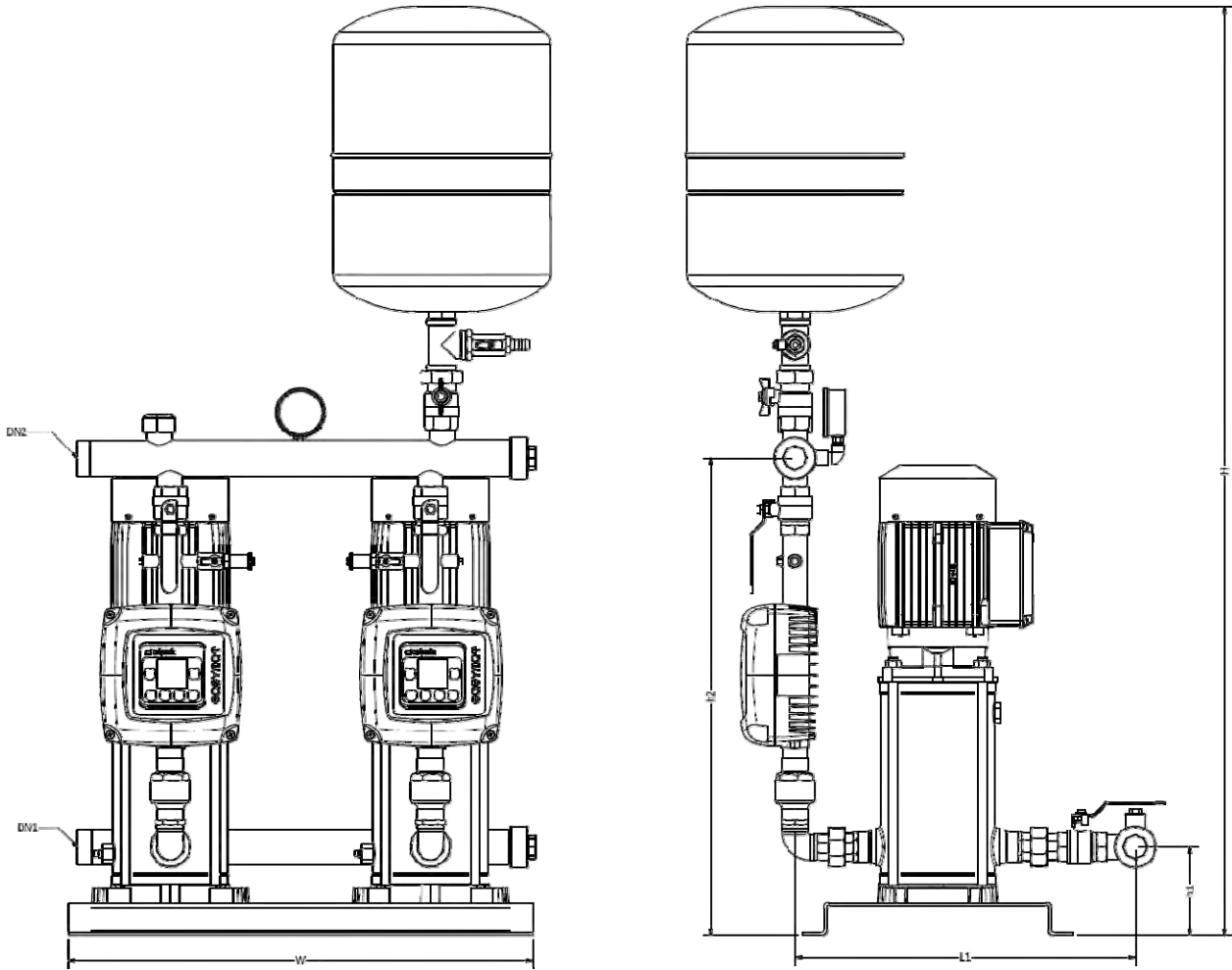

Model Number	DN1	DN2	mm				
			H	W	L1	h1	h2
2MXV-B25-204-EMT-24	G1-1/2"	G1-1/2"	1200	625	510	115	590
2MXV-B25-205-EMT-24			1200	625	510	115	590
2MXV-B25-206-EMT-24			1200	625	510	115	590
2MXV-B25-207-EMT-24			1200	625	510	115	590
2MXV-B25-208-EMT-24			1200	625	510	115	590
2MXV-B25-210-EMT-24			1200	625	510	115	590
2MXV-B32-404-EMT-24	G2"	G2"	1230	625	535	115	685
2MXV-B32-405-EMT-24			1230	625	535	115	685
2MXV-B32-406-EMT-24			1230	625	535	115	685
2MXV-B32-407-EMT-24			1230	625	535	115	685
2MXV-B32-408-EMT-24			1230	625	535	115	685
2MXV-B32-410-EMT-24			1230	625	535	115	685
2MXV-B40-804-EMT-24	G2-1/2"	G2-1/2"	1285	625	590	120	755
2MXV-B40-805-EMT-24			1285	625	590	120	755
2MXV-B40-806-EMT-24			1285	625	590	120	755

Note:
Dimensions stated are Pre Production. Allow tolerance of 5%.

DIMENSIONS

easymat three pump variable speed booster set with MXV-B pump

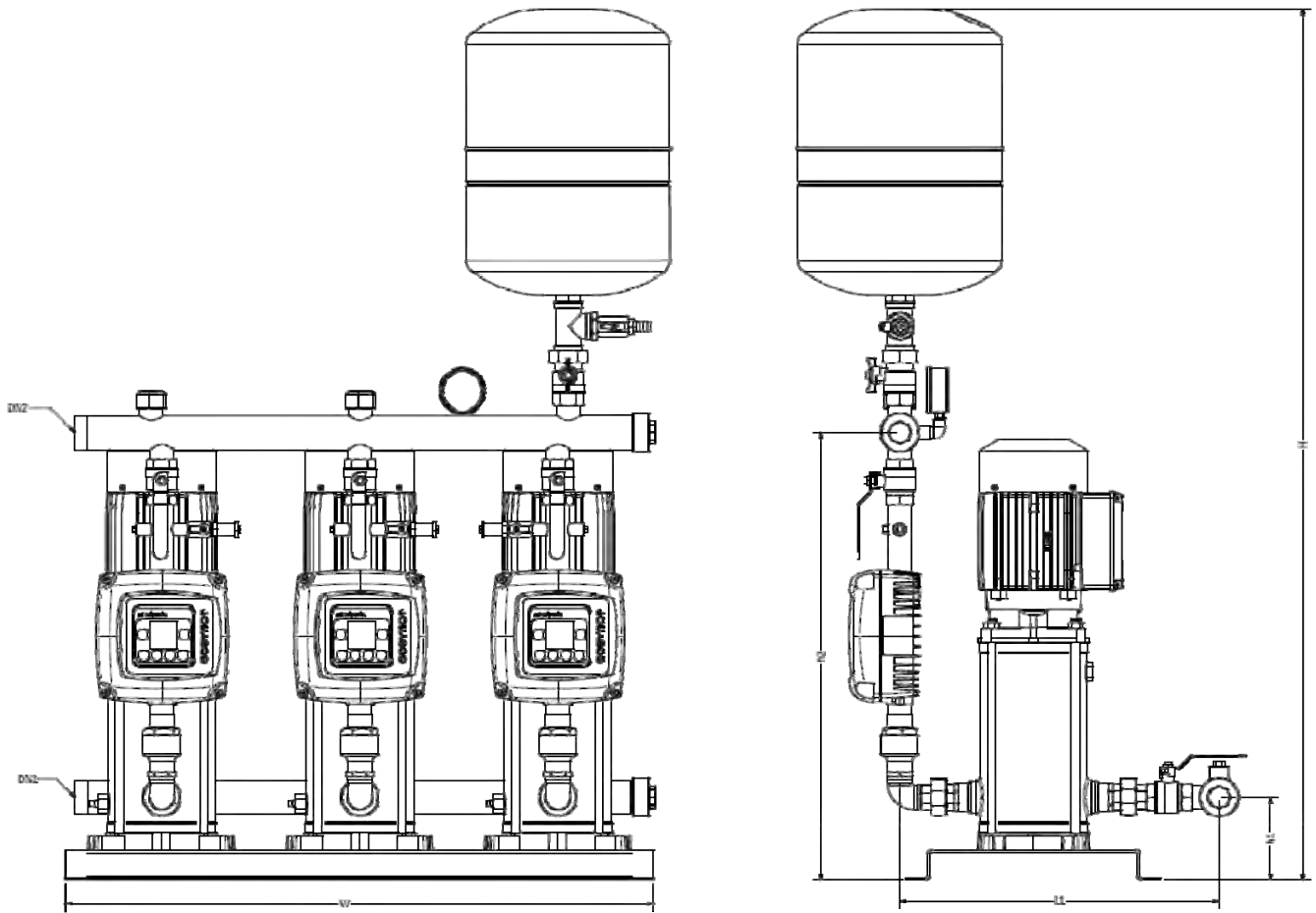

Model Number	DN1	DN2	mm				
			H	W	L1	h1	h2
3MXV-B25-204-EMT-24	G2"	G2"	1320	1000	520	130	670
3MXV-B25-205-EMT-24			1320	1000	520	130	670
3MXV-B25-206-EMT-24			1320	1000	520	130	670
3MXV-B25-207-EMT-24			1320	1000	520	130	670
3MXV-B25-208-EMT-24			1320	1000	520	130	670
3MXV-B25-210-EMT-24			1320	1000	520	130	670
3MXV-B32-404-EMT-24	G2-1/2"	G2-1/2"	1340	1000	545	130	690
3MXV-B32-405-EMT-24			1340	1000	545	130	690
3MXV-B32-406-EMT-24			1340	1000	545	130	690
3MXV-B32-407-EMT-24			1340	1000	545	130	690
3MXV-B32-408-EMT-24			1340	1000	545	130	690
3MXV-B32-410-EMT-24			1340	1000	545	130	690
3MXV-B40-804-EMT-24	G3"	G3"	1440	1000	600	135	790
3MXV-B40-805-EMT-24			1440	1000	600	135	790
3MXV-B40-806-EMT-24			1440	1000	600	135	790

Note:
Dimensions stated are Pre Production. Allow tolerance of 5%.

IMAT CONTROL



Benefits

Flexibility

I-MAT frequency converters are equipped with a software which provide different operating modes in order to cover a wide range of applications.

Reliability

The high efficiency heatsink with integrated fans allows to cool the frequency converter independently from the motor, to provide a higher reliability of the system.

Safety

The shape of the I-MAT frequency converters allows to separate the signal terminals area, from the power terminals area, in this way the user can operate on the signals connections in safety conditions.

Easy to use

The integrated control panel allows to program all the parameters directly on the frequency converters. Moreover it's possible to remove the control panel and remote it with a connection cable.

Communications between units

The system flexibility allows, with an optional electronic card, to assemble more units making them communicate together. The system is capable to manage variable speed pumps (up to 6) and fixed speed pump (up to 5).

Construction

Variable speed system driven by frequency converter for the motor control in the water supply applications and in the production/distribution of hot/cold water.

I-MAT is an integrated control system which, applied to the motor, allows to manage a wide range of applications and operating modes.

Applications

Frequency converter for automatic pump control suitable for:

- water supply
- water transport and distribution
- production and distribution of hot/cold water
- water treatment

For protection of the pumps:

- Against dry running
- Against operations with closed connection ports
- Against overcurrent of the motor
- Against overvoltage and undervoltage of the power supply
- Against unbalance or missing supply phases.

Operating conditions

Standard voltage: 400 V \pm 10% (380-415V) three-phase

Input voltage: 3~380V-10% \div 3~480V+5%

Output voltage: 0 \div 100% of the input voltage

Input frequency: 50-60 Hz

Output frequency: up to 70 Hz

Protection: IP55

Max Ambient Temperature: 50°C

Altitude: no higher than 1000 m, inside closed environment.

Construction

(standard execution)

The system comprises of:

- Frequency converter
- Removable control panel
- Power terminal board
- Signals terminal board
- Cable glands

On request:

- Adapter for motor mounting
- Adapter for wall mounting
- Pressure and temperature transducer
- Main switch
- Line filter and output filter

Type

Type (three-phase)	Frequency converter max current output A	Standard power motor 400V kW
I-MAT 5,2 TT-A	5,2	0,55 \div 1,8
I-MAT 11,2 TT-B	11,2	2,2 \div 4
I-MAT 25,8 TT-C	25,8	5,5 \div 11

IMAT SETS

General Information

A range of high specification variable speed cold water booster sets with multi-pump options up to 6 pumps. The sets feature the IMAT variable speed controller with either our stainless steel MXH series or MXV series multi-stage pumps. We can also build special systems with any of the pumps from our range to suit specific applications.

Pumps

MXH all stainless steel horizontal multi-stage centrifugal pumps (WRAs Approved)

MXV stainless steel vertical multi-stage centrifugal pumps (WRAs Approved)

Motors

Aluminium 2-pole (2900 rpm) induction motors, 400/3/50, class F insulation, IP54 and IP55 protection.

System

One piece stainless steel manifolds, and brass fittings with WRAs approved valves, WRAs approved GWS accumulator all mounted on a mild steel powder coated baseplate, fully wired and tested.

Operating Conditions

Fluid:	Clean Cold Water.	Control:	IMAT variable speed via Pressure Transducer, Differential Transducer or Temperature Transducer
Fluid Temp:	Max 25 Deg.C.	Max Press:	10 bar Operational Pressure
Air Amb:	Max 40 Deg.C	Rated:	Continuous Service



FEATURES

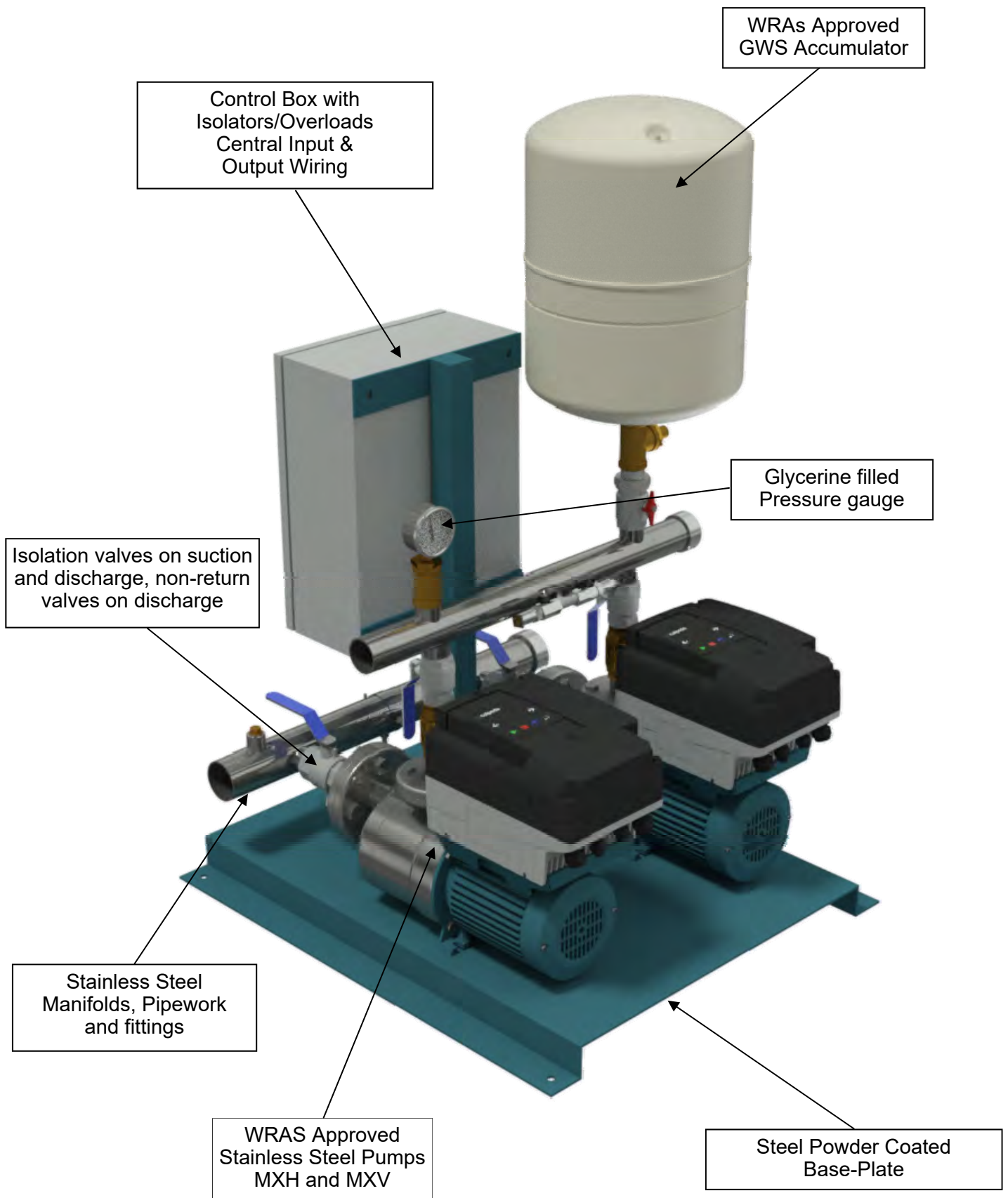

IMAT CONTROL

Control panel

The integrated control panel gives the customer the possibility to set all the parameters of the frequency converter.

Optional modules

On the front side of the frequency converter are predisposed compartments for connecting the optional modules. This solution allows to install the modules without dismantling the frequency converter.

Main switch

The frequency converters have the possibility (optional) to install a main switch.



Power connection area

The connection area is protected by a safety cover, there are dedicated clamps to connect one PTC probe.

I/O connection area

The connection area for the input/outputs is separated from the power connection area, this solution allows to connect external.

Heatsink

The high efficiency heat sink cooled by fans guarantees a high reliability. The side connection system allows an easy connection with the motors.

IMAT CONTROL

Operating modes



Constant pressure mode

Constant pressure keeps the pressure constant at a fixed value set by the user. This value of pressure is automatically kept by the system to provide to the final user a constant pressure even with different water demand, within the maximum performance of the motor-pump system.



Proportional pressure modes

Proportional pressure reduces the pressure of the pump (and as a consequence, the operating frequency) proportionally with the water demand of the system.



Constant temperature mode

In this operating mode the system is used to keep the temperature at a constant value in a specified system point.



Constant flow mode

Constant flow mode grants that system change the speed of the pump in order to keep constant the flow which pass inside a flow meter.



Fixed speed mode

In this operating mode the system work as a fixed speed pump. The speed of the pump could be set by the user between a range of speeds, or controlled by an external signal.



Night mode

The night mode is an optional mode which allows to reduce the speed of the pump if the temperature in the system decreases below a set value, this operating mode can be used with all operating modes over described.

Control Panel



I-MAT is equipped with a control panel that allows to carry out the set-up of the system and to monitor all system parameters.

The control panel is inside a IP55 enclosure which is possible to rotate and install in remote positions.

It is possible use the control panel in remote positions by means a cable with M12 connectors (standard cable).

The LCD custom display gives an easy overview of the system situation and of the operating parameters.

The icons on the top and below the display area explain in which way i-MAT is working and if there are some problems on the system.

The 2 scroll buttons are used to scroll the different operating parameters that i-MAT can show. At the same time you can use the 2 scroll buttons to move in the set up menu and to change the different options.

The 4 set-up buttons are created to enter and to move on the set-up menus and to start and to stop the pump. The symbols help to understand the function of each button. With these 4 buttons and the 2 scroll buttons you can manage all the set-up and operating parameters without the use of another control panel or computers.

DIMENSIONS

imat twin pump variable speed booster set with MXH pump

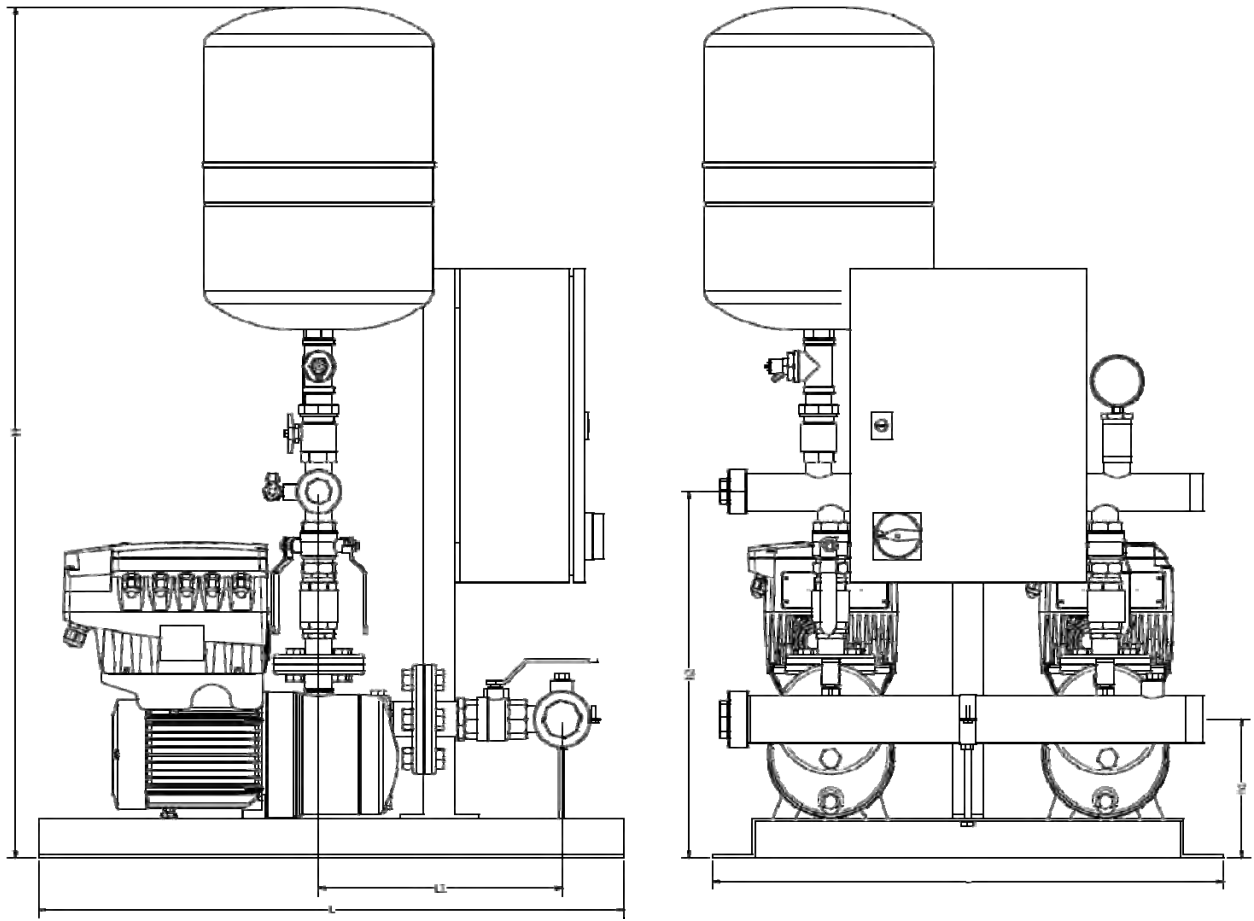

Model Number	DN1	DN2	mm					
			H	W	L	L1	h1	h2
2MXH202E-TTA-24	2" BSP	1-1/2" BSP	1180	650	745	305	175	485
2MXH203E-TTA-24			1180	650	745	305	175	485
2MXH204/A-TTA-24			1180	650	745	330	175	485
2MXH205/A-TTA-24			1180	650	745	355	175	485
2MXH206/B-TTA-24			1180	650	745	380	175	485
2MXH402E-TTA-24			1180	650	745	305	175	485
2MXH403/A-TTA-24			1180	650	745	305	175	485
2MXH404/A-TTA-24			1180	650	745	330	175	485
2MXH405/B-TTA-24			1180	650	745	355	175	485
2MXH406-TTA-24			1180	650	745	380	175	485
2MXH802/A-TTA-24	2-1/2" BSP	2" BSP	1200	650	950	365	175	500
2MXH803-TTA-24			1200	650	950	365	175	500
2MXH804-TTA-24			1200	650	950	395	175	500
2MXH805/A-TTA-24			1200	650	950	425	175	500

Note:
Dimensions stated are Pre Production. Allow tolerance of 5%.

DIMENSIONS

imat twin pump variable speed booster set with MXH pump (continued)

Model Number	DN1	DN2	mm					
			H	W	L	L1	h1	h2
2MXH1602-TTA-24	3" BSP	2-1/2" BSP	1300	650	1100	415	180	600
2MXH1603/A-TTA-24			1300	650	1100	415	180	600
2MXH1604/A-TTB-24			1300	650	1100	455	180	600
2MXH1605/A-TTB-24			1300	650	1100	480	180	600
2MXH1606/A-TTB-24			1300	650	1100	530	180	600
2MXH-F3201/A-TTB-24	DN100	DN80	1525	900	1200	500	225	785
2MXH-F3202/A-TTB-24			1525	900	1200	500	225	785
2MXH-F3203/A-TTC-24			1525	900	1200	545	225	785
2MXH-F3204/A-TTC-24			1525	900	1200	590	225	785
2MXH-F4801/A-TTB-24	DN125	DN100	1575	900	1200	550	225	830
2MXH-F4802/A-TTC-24			1575	900	1200	550	225	830
2MXH-F4803/A-TTC-24			1575	900	1200	610	225	830

Note:

Dimensions stated are Pre Production. Allow tolerance of 5%.

DIMENSIONS

imat three pump variable speed booster set with MXH pump

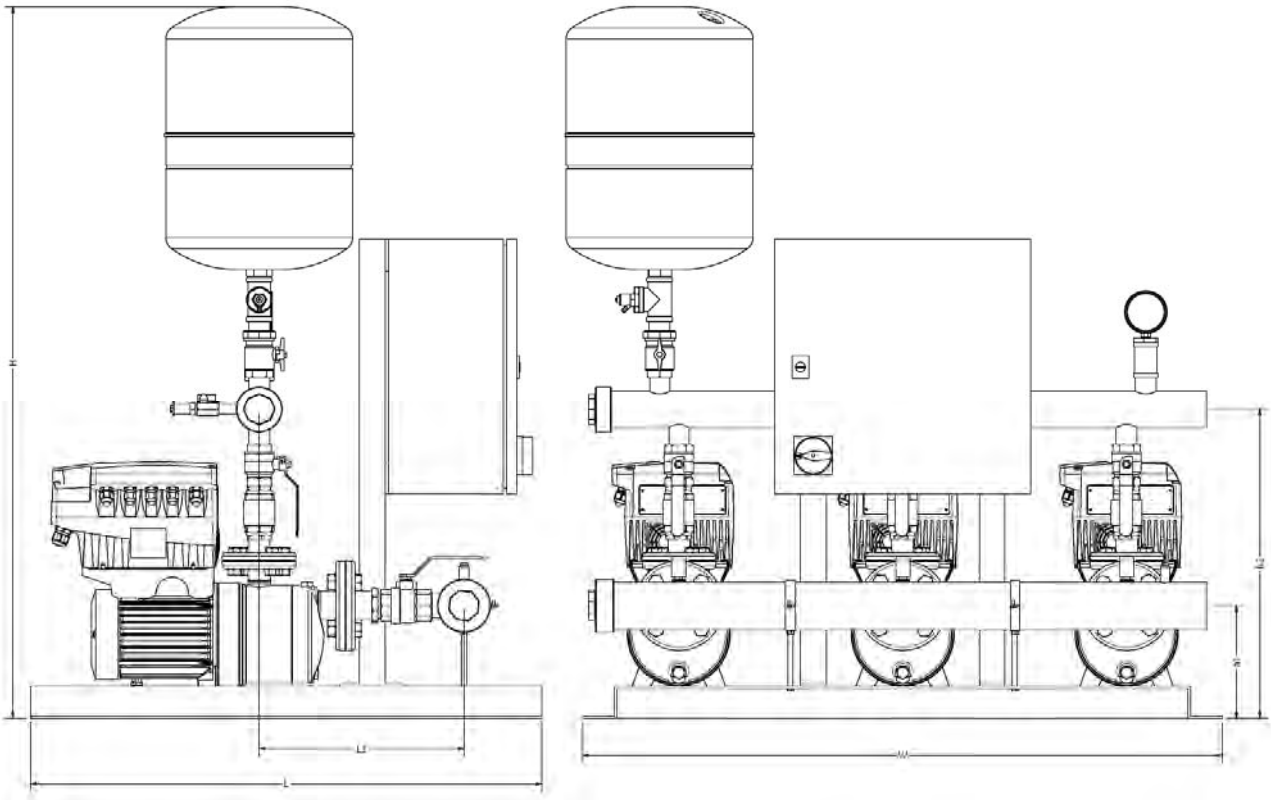

Model Number	DN1	DN2	mm					
			H	W	L	L1	h1	h2
3MXH202E-TTA-24	2-1/2" BSP	2" BSP	1220	1000	800	320	175	510
3MXH203E-TTA-24			1220	1000	800	320	175	510
3MXH204/A-TTA-24			1220	1000	800	345	175	510
3MXH205/A-TTA-24			1220	1000	800	370	175	510
3MXH206/B-TTA-24			1220	1000	800	395	175	510
3MXH402E-TTA-24			1220	1000	800	320	175	510
3MXH403/A-TTA-24			1220	1000	800	320	175	510
3MXH404/A-TTA-24			1220	1000	800	345	175	510
3MXH405/B-TTA-24			1220	1000	800	370	175	510
3MXH406-TTA-24			1220	1000	800	395	175	510
3MXH802/A-TTA-24	3" BSP	2-1/2" BSP	1220	1000	950	370	175	520
3MXH803-TTA-24			1220	1000	950	370	175	520
3MXH804-TTA-24			1220	1000	950	400	175	520
3MXH805/A-TTA-24			1220	1000	950	430	175	520

Note:
Dimensions stated are Pre Production. Allow tolerance of 5%.

DIMENSIONS

imat three pump variable speed booster set with MXH pump (continued)

Model Number	DN1	DN2	mm					
			H	W	L	L1	h1	h2
3MXH1602-TTA-24	DN100	DN80	1380	1000	1200	425	180	640
3MXH1603/A-TTA-24			1380	1000	1200	425	180	640
3MXH1604/A-TTB-24			1380	1000	1200	460	180	640
3MXH1605/A-TTB-24			1380	1000	1200	495	180	640
3MXH1606/A-TTB-24			1380	1000	1200	530	180	640
3MXH-F3201/A-TTB-24	DN125	DN100	1575	1000	1300	550	225	800
3MXH-F3202/A-TTB-24			1575	1000	1300	550	225	800
3MXH-F3203/A-TTC-24			1575	1000	1300	595	225	800
3MXH-F3204/A-TTC-24			1575	1000	1300	640	225	800
3MXH-F4801/A-TTB-24	DN150	DN125	1650	1200	1300	610	300	840
3MXH-F4802/A-TTC-24			1650	1200	1300	610	300	840
3MXH-F4803/A-TTC-24			1650	1200	1300	670	300	840

Note:

Dimensions stated are Pre Production. Allow tolerance of 5%.

DIMENSIONS

imat twin pump variable speed booster set with MXV pump

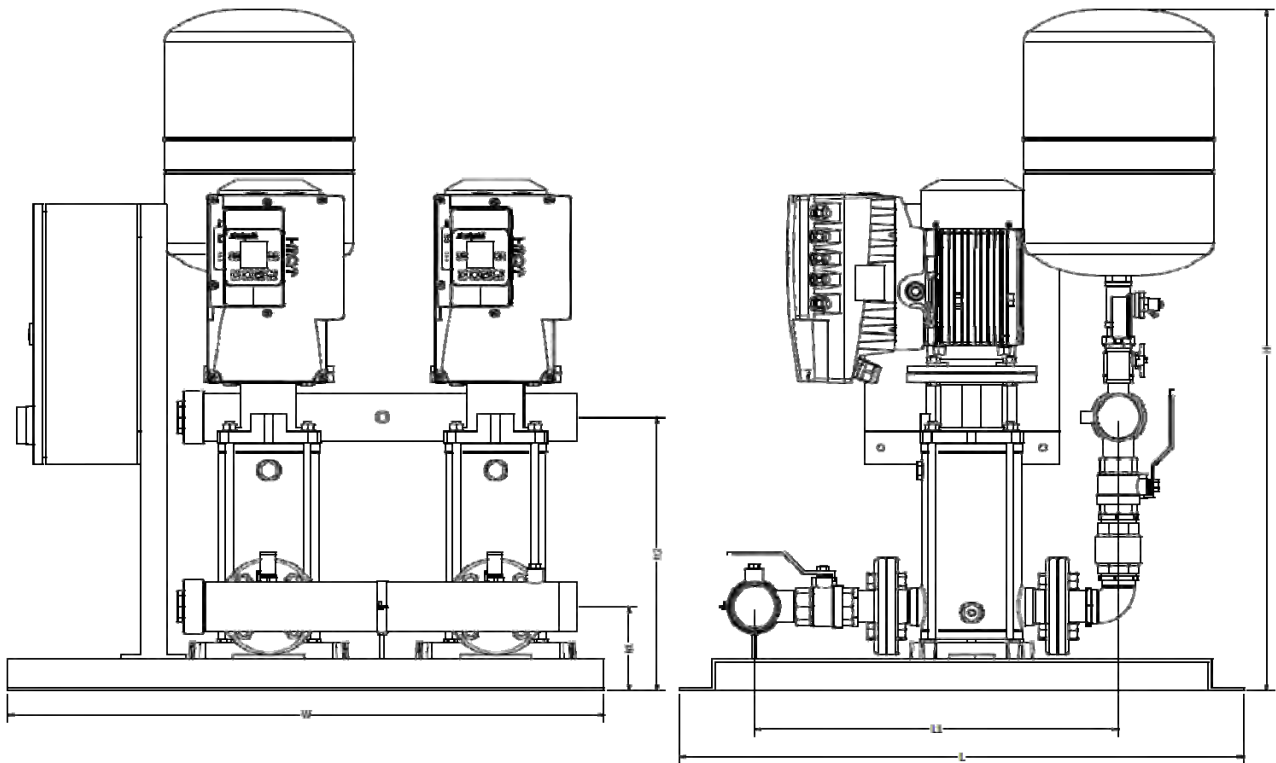

Model Number	DN1	DN2	mm					
			H	W	L	L1	h1	h2
2MXV25-204/C-TTA-24	1-1/2" BSP	1-1/2" BSP	990	900	725	540	125	350
2MXV25-205/C-TTA-24			990	900	725	540	125	350
2MXV25-206/C-TTA-24			990	900	725	540	125	350
2MXV25-207/C-TTA-24			990	900	725	540	125	350
2MXV25-208/C-TTA-24			990	900	725	540	125	350
2MXV25-210/C-TTA-24			990	900	725	540	125	350
2MXV32-404/C-TTA-24	2" BSP	2" BSP	1040	900	725	590	125	400
2MXV32-405/C-TTA-24			1040	900	725	590	125	400
2MXV32-406/C-TTA-24			1040	900	725	590	125	400
2MXV32-407/C-TTA-24			1040	900	725	590	125	400
2MXV32-408/C-TTB-24			1040	900	725	590	125	400
2MXV32-410/C-TTB-24			1040	900	725	590	125	400
2MXV40-804/C-TTA-24	2-1/2" BSP	2-1/2" BSP	1090	920	870	660	130	445
2MXV40-805/C-TTB-24			1090	920	870	660	130	445
2MXV40-806/C-TTB-24			1090	920	870	660	130	445
2MXV40-807/C-TTB-24			1090	920	870	660	130	445
2MXV40-808/C-TTB-24			1090	920	870	660	130	445
2MXV40-810/C-TTB-24			1090	920	870	660	130	445

Note:
Dimensions stated are Pre Production. Allow tolerance of 5%.

DIMENSIONS

imat twin pump variable speed booster set with MXV pump

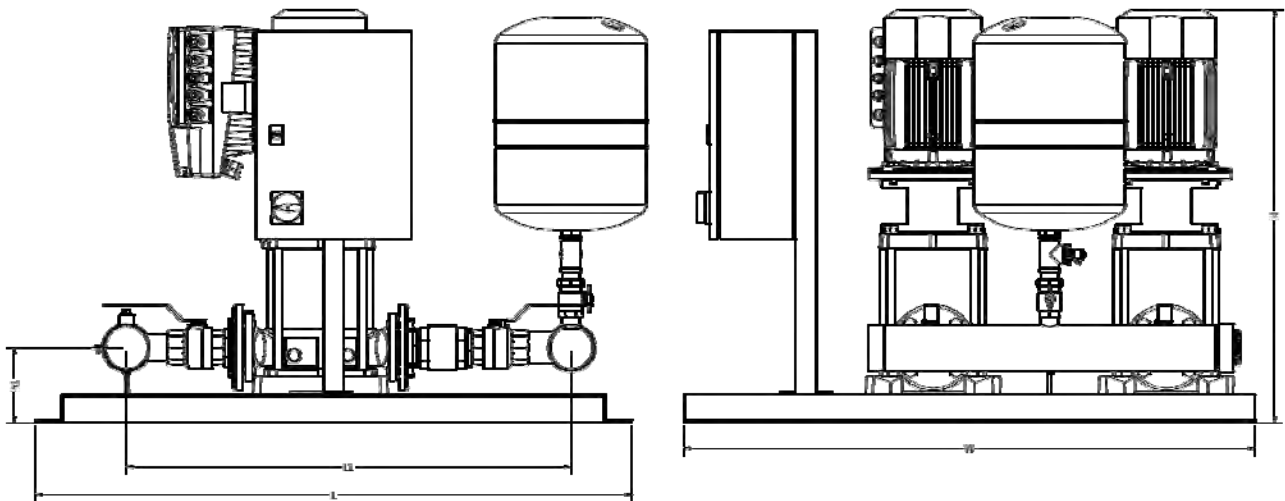

Model Number	DN1	DN2	mm				
			H	W	L	L1	h1
2MXV50-1603/C-TTB-24	3" BSP	3" BSP	795	1100	1200	880	140
2MXV50-1604/C-TTB-24			800	1100	1200	880	140
2MXV50-1605/C-TTC-24			875	1100	1200	880	140
2MXV50-1606/C-TTC-24			910	1100	1200	880	140
2MXV65-3202/C-TTB-24	DN100	DN100	795	1100	1200	1065	160
2MXV65-3203/C-TTC-24			865	1100	1200	1065	160
2MXV65-3204/C-TTC-24			910	1100	1200	1065	160
2MXV65-3205/C-TTC-24			1100	1100	1200	1065	160
2MXV80-4801/C-TTB-24	DN125	DN125	775	1100	1400	1235	160
2MXV80-4802/C-TTC-24			855	1100	1400	1235	160
2MXV80-4803/C-TTC-24			915	1100	1400	1235	160
2MXV80-4804/C-TTC-24			1125	1100	1400	1235	160

Note:

Dimensions stated are Pre Production. Allow tolerance of 5%.

DIMENSIONS

imat three pump variable speed booster set with MXV pump

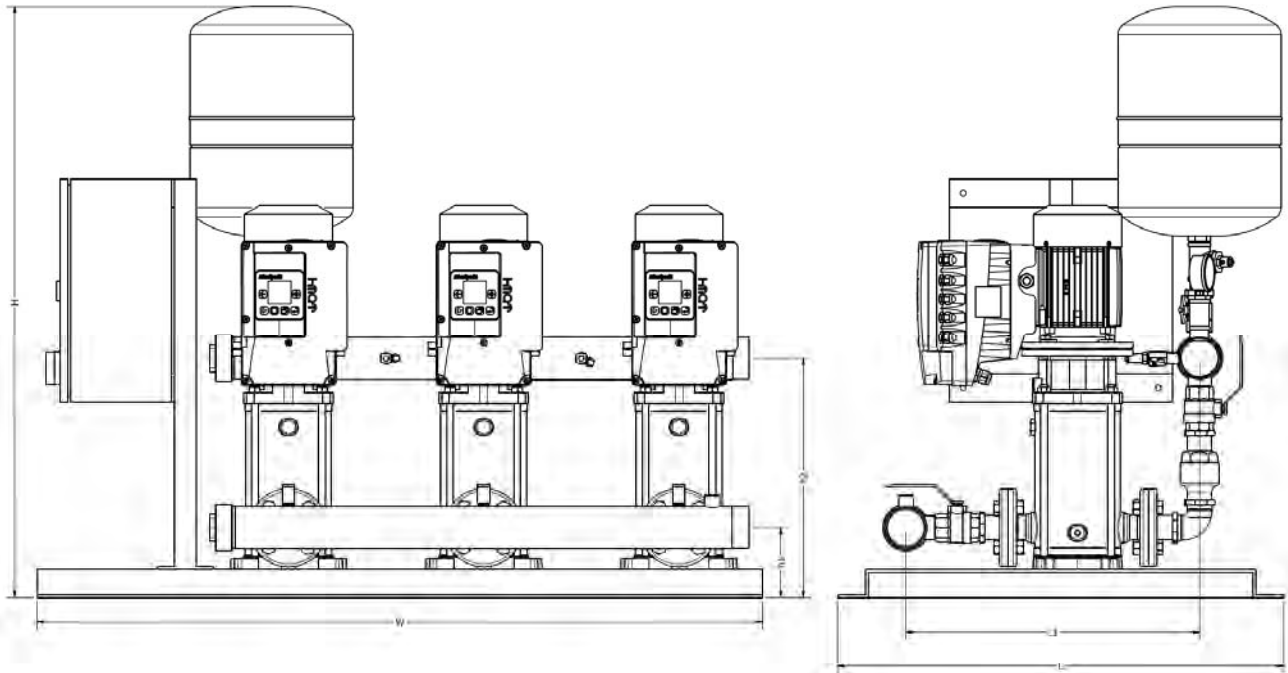

Model Number	DN1	DN2	mm					
			H	W	L	L1	h1	h2
3MXV25-204/C-TTA-24	2" BSP	2" BSP	1000	1300	900	550	125	365
3MXV25-205/C-TTA-24			1000	1300	900	550	125	365
3MXV25-206/C-TTA-24			1000	1300	900	550	125	365
3MXV25-207/C-TTA-24			1000	1300	900	550	125	365
3MXV25-208/C-TTA-24			1000	1300	900	550	125	365
3MXV25-210/C-TTA-24			1000	1300	900	550	125	365
3MXV32-404/C-TTA-24	2-1/2" BSP	2-1/2" BSP	1055	1300	900	605	125	460
3MXV32-405/C-TTA-24			1055	1300	900	605	125	460
3MXV32-406/C-TTA-24			1055	1300	900	605	125	460
3MXV32-407/C-TTA-24			1055	1300	900	605	125	460
3MXV32-408/C-TTB-24			1055	1300	900	605	125	460
3MXV32-410/C-TTB-24			1055	1300	900	605	125	460
3MXV40-804/C-TTA-24	3" BSP	3" BSP	1100	1300	900	680	130	460
3MXV40-805/C-TTB-24			1100	1300	900	680	130	460
3MXV40-806/C-TTB-24			1100	1300	900	680	130	460
3MXV40-807/C-TTB-24			1100	1300	900	680	130	460
3MXV40-808/C-TTB-24			1100	1300	900	680	130	460
3MXV40-810/C-TTB-24			1100	1300	900	680	130	460

Note:
Dimensions stated are Pre Production. Allow tolerance of 5%.

DIMENSIONS

imat three pump variable speed booster set with MXV pump

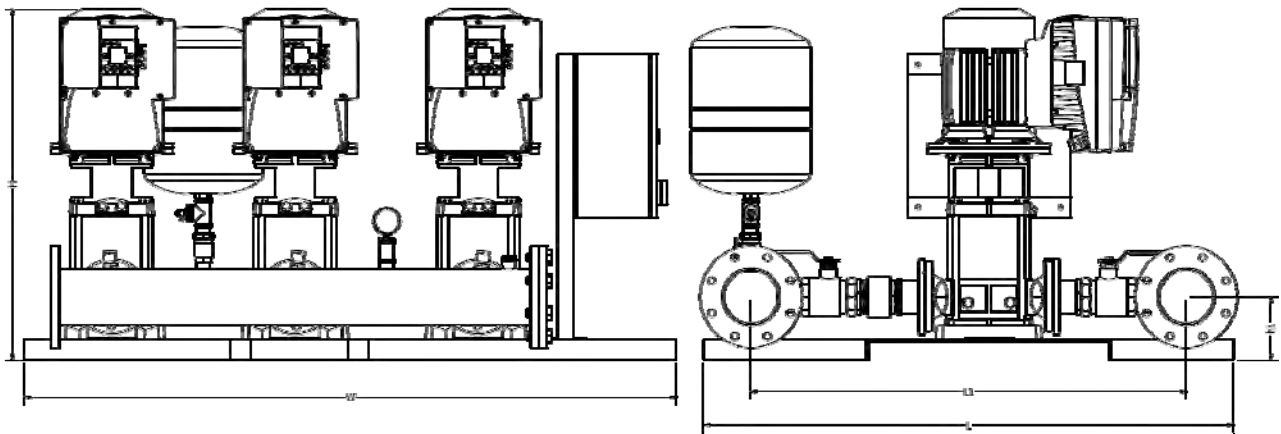

Model Number	DN1	DN2	mm				
			H	W	L	L1	h1
3MXV50-1603/C-TTB-24	DN100	DN100	820	1600	1400	1165	145
3MXV50-1604/C-TTB-24			820	1600	1400	1165	145
3MXV50-1605/C-TTC-24			875	1600	1400	1165	145
3MXV50-1606/C-TTC-24			910	1600	1400	1165	145
3MXV65-3202/C-TTB-24	DN125	DN125	830	1600	1400	1165	155
3MXV65-3203/C-TTC-24			865	1600	1400	1165	155
3MXV65-3204/C-TTC-24			910	1600	1400	1165	155
3MXV65-3205/C-TTC-24			1105	1600	1400	1165	155
3MXV80-4801/C-TTB-24	DN150	DN150	915	1600	1400	1165	155
3MXV80-4802/C-TTC-24			915	1600	1400	1165	155
3MXV80-4803/C-TTC-24			920	1600	1400	1165	155
3MXV80-4804/C-TTC-24			1125	1600	1400	1165	155

Note:

Dimensions stated are Pre Production. Allow tolerance of 5%.

