

---

# Operating Instructions

## Reverse Osmosis Systems UO 4300/5400/6000/7000/8000/9000/12000 ND



---

## Overview of contents

General information	A
Transport and storage	B
Technical data/ product description	C
Set-up and assembly	D
Placing the system in service / taking it out of service	E
Operation / monitoring	F
Malfunctions	G
Maintenance	H
Preserving/Cleaning the system	I

## Appendix

- R+I flowchart with components list	I
- Circuit diagram	II
- Control system manual	III
- Setting data RO 1000	IV

---

## Imprint

All Rights Reserved.

The edition date on the cover sheet is definitive.  
Subject to technical changes.

These Operating Instructions may not be translated into foreign languages, reprinted, saved on data media or otherwise duplicated except with the express written approval of the manufacturer.

## Contents of Chapter A

1. Notes on using the Operating Instructions.....	2
2. General safety information .....	3
2.1 Explanation of symbols and references .....	3
2.2 Additional safety requirements.....	3
2.3 Usage in accordance with intended purpose.....	3
2.4 Operating staff .....	3
2.5 Residual dangers .....	4
2.6 Bringing the system to a stop in the event of an emergency.....	4
2.7 Safety information for maintenance tasks .....	4
2.7 Disposing of system parts and operating materials .....	5
2.8 Unauthorized conversion and manufacturing replacement parts.....	5
2.9 Warrantee claims and liability .....	5
3. Basic principles of reverse osmosis systems.....	6
3.1 The principle of reverse osmosis .....	6
3.2 Calculation equations .....	6
3.3 Temperature dependency of permeate output.....	7

## 1. Notes on using the Operating Instructions

**Purpose:** The Operating Instructions are intended for users of the system and contain information on how to operate and maintain the system safely and reliably.

**Availability:** The Operating Instructions must always be available at the place where the system is in use.

**Subdivision:** The Operating Instructions consist of a number of chapters named by letters of the alphabet. An outline of all the chapters appears on Page 1. The header and page numbering, along with the letter identifying each chapter, make it easier for you to orient yourself. For information on the content of a specific chapter, please refer to the contents on the first page of that chapter.

<b>Conventions/ abbreviations:</b>	OI	Operating Instructions
	TD	Technical Documentation
	RO	Reverse Osmosis
	Permeate	Product water resulting from RO
	Product	Product water from the UP system
	Cy	Conductivity
	-	Enumerated items
		Steps to be performed

## 2. General safety information

### 2.1 Explanation of symbols and references



Danger

This symbol refers to an immediate danger that threatens the safety and life of persons. Failure to observe these notices will have severe consequences on health and safety, including life-threatening injuries.



Warning

This symbol refers to a possible danger that threatens the safety and life of persons. Failure to observe these notices may have severe consequences on health and safety, including life-threatening injuries.



Caution

This symbol refers to a possibly hazardous situation. Failure to observe these references may result in minor injuries and/or damage to property.



This symbol points out important information for working with the system in a proper manner. Failure to observe these references may result in malfunctions in the system or disturbances in the environment.

### 2.2 Additional safety requirements

Country-specific requirements, standards and regulations must be observed.

### 2.3 Usage in accordance with intended purpose

The RO-system is used to desalinate softened water. The system must only be operated with water supplied in accordance with the quality described in Chapter C/2 and the operating parameters specified there.

The system must not be operated unless it is in proper working order. Any malfunctions must be rectified immediately.

### 2.4 Operating staff

Only persons who have read and understood these Operating Instructions are permitted to operate the system. When operating the system, it is particularly important to observe the safety information strictly.

## 2.5 Residual dangers



Danger

- Water damage
  - To avoid accumulation of spills caused by leaks, the area in which the system is set up must be equipped with a floor drain and/or a leak monitoring system and corresponding alarm.
- Electrical shock
  - Do not touch electrical components with wet hands.
  - Before performing tasks on parts of electrical system, disconnect the system from the power supply.
- Mechanical force
  - Parts of the system are under excess pressure of up to 25. Release the pressure from the system before repairs and maintenance tasks.

## 2.6 Bringing the system to a stop in the event of an emergency

- ☞ Turn off the main switch
- ☞ Shut off the water supply

After remedying the damage:

- ☞ Open the water supply
- ☞ Turn on the main switch

## 2.7 Safety information for maintenance tasks

The operator must take pains to ensure that all maintenance, inspection and assembly tasks are performed by authorized and qualified professionals who have been sufficiently informed for the task at hand by thoroughly studying the Operating Instructions. These tasks must be properly performed by professionally trained staff members.

The system must be shut down and protected from being placed in operation again unintentionally before all repair and maintenance tasks. It is absolutely essential to observe the procedure described in these Operating Instructions for shutting down the system.

Before beginning tasks on the electrical equipment of the system, a check must confirm that power has been disconnected from the corresponding section of the system. In addition, the system must be secured to prevent it from being turned on again unintentionally.

Protective clothing suitable for the hazard at hand must be worn while performing the task.

## **2.7 Disposing of system parts and operating materials**

When they need to be discarded, system parts must be disposed of according to local requirements including separately if so required.

## **2.8 Unauthorized conversion and manufacturing replacement parts**

Conversion or modification of the system is only permitted with the approval of the manufacturer. The same applies to making changes in the programming for the control system. Original replacement parts and accessories authorized by the manufacturer enhance safety. Use of other parts will void the warrantee.

## **2.9 Warrantee claims and liability**

This product corresponds to the state of the art and was designed and manufactured in accordance with applicable rules of the technology, after which it was subjected to a quality control process. If there should nevertheless be any grounds for complaint, please direct requests for replacement to the manufacturer of this product in accordance with the general terms and conditions of sale and delivery.

### 3. Basic principles of reverse osmosis systems

#### 3.1 The principle of reverse osmosis

Osmosis is a process on which nearly all natural metabolic processes are based. If two solutions of varying concentrations are separated in a system by a semipermeable membrane, the solution with the higher concentration will always have a tendency to become more diluted. This process (osmosis) will continue until osmotic equilibrium is achieved.

In the process of reverse osmosis, the direction of the osmotic flow is reversed. To achieve this, pressure must be exerted on the concentrated solution. This pressure must be considerably greater than the osmotic pressure that arises due to the natural balancing of differing concentrations.

Synthetic membranes are used in water treatment systems that work on the principle of reverse osmosis. These membranes are permeable for water molecules. The content materials dissolved in the water are held back by the membranes. High pressure causes the concentrated solution (for example drinking water or process water) to flow through these membranes. The result is a separation of this solution into a partial flow with water in which the content materials that are held back are located (concentrate).

#### 3.2 Calculation equations

$$\text{Yield [\%]} = \frac{\text{permeate output [l/h]} \cdot 100\%}{\text{feed water input [l/h]}}$$

feed water input = Permeate output + concentrate output

$$\text{Concentrate output [l/h]} = \frac{\text{permeate output [l/h]} \cdot 100\%}{\text{yield [\%]}} - \text{permeate output [l/h]}$$

$$\text{Desalinization rate [\%]} = \left[1 - \frac{C_{y \text{ permeate}}}{C_{y \text{ raw water}}}\right] \cdot 100\%$$



### 3.3 Temperature dependency of permeate output



The permeate output of the system depends on the temperature of the feed water. The nominal output specified in the technical data and on the rating plate refers to the design temperature specified in Chapter C/2.

The actual output at a specific feed water temperature can be calculated from the following table using a correction factor.

The specific temperature-related permeate output can be calculated according to the following calculation equation:

$$\text{Permeate output at X } ^\circ\text{C} = \text{Rate output} \cdot \text{Correction factor F}$$

T in °C		Correction factor
Design temperature	Nominal output = 100%	1.00
-1		0.96
-2		0.92
-3		0.88
-4		0.84
-5		0.80
-6		0.77
-7		0.74
-8		0.70
-10		0.67
-11		0.64



**If the system is operated at a higher feed water temperature than the design temperature, care must be taken not to exceed the maximum permeate output that is specified on the rating plate and in the technical data (C/2)!**



After switching on the RO system permeate with high conductivity is produced for a short time. Therefore it is to be made certain during the interpretation of the peripheral equipment technology that a minimum running time of the RO system of at least 30 min per shifting process is ensured.

### 1. Transport and storage

- Systems of type RS and RSE, ND,KR, AS, ES, combi, ED,NF, UP and EP should be transported upright.
- Systems of type W should be transported lying down.
- Systems of type W/S may be transported either standing or lying down.



- **During transport, all systems must be secured against slipping and falling over!**
- The transport weight corresponds to the empty weight. For transport weights, please refer to the Technical Data in Chapter C/2.
- The system can be damaged by frost. Because of this, the system must be protected against frost and freezing during transport and storage.
- The maximum storage temperature is 40°C.
- The maximum storage duration for the system in original packing is 3 months at 20 °C. After that, the preservative fluid must be rinsed out and replaced if necessary.

## Contents of Chapter C

2. Usage limits .....	4
3. Product description .....	5
3.1 Rating plate .....	5
3.2 Working principle diagram .....	5
3.3 Functional description .....	5
3.4 Short description of the components .....	6
3.5 Options .....	7

## Technical Data

System		UO 4300 ND	UO 5400 ND	UO 6000 ND	UO 7000 ND	UO 8000 ND	UO 9500 ND	UO 12.000 ND
Code No.		381440	381450	381203	381460	381470	381480	381490
Control		RO 1000						
<b>Feed water specification</b>								
Feed water pressure min./max.	bar	2/6						
Pressure fluctuations (limit)	bar	± 0,5						
Temperature min./max.	°C	5/35						
<b>Connections</b>								
Feed water	DN	32	40	40	40	50	50	50
Permeate	DN	32	32	40	40	40	50	50
Concentrate	DN	32	32	32	32	32	32	50
Power consumption	kW	5,5			7,5	11		
Power connection	V/Hz	3x400/50						
Protection type		IP 54						
<b>Output data</b>								
Permeate outlet max.	l/h	4300	5400	6000	7000	8000	9500	12000
Concentrate min.	l/h	1430	1800	2000	2330	2660	3160	4000
Concentrate backflow	l/h	3500	3100	2700	2700	2200	1300	2700
Pump pressure max.	bar	25						
Permeate counterpressure max.	bar	0,3, without permeate backflow						
Recovery	%	75						
Salt rejection rate	%	97						
<b>Dimensions and weights</b>								
Dimensions (HxWxD)	mm	1800x2800x750	1800x2800x750	1800x3800x750	1800x3800x750	1850x3800x800	1850x4800x800	1850x3900x800
Weight approx.	kg	450	500	600	600	700	800	900
<b>Environmental data</b>								
Max. ambient temperature	°C	40						
Relative humidity (air)	%	<95, non-condensing						

Systems are designed for softened drinking water without chlorine in accordance with the German Drinking Water Regulation with a salt content of 1000 mg/l and at a feed water temperature of 15°C.

System		UO 4300 ND/FU	UO 5400 ND/FU	UO 6000 ND/FU	UO 7000 ND/FU	UO 8000 ND/FU	UO 9500 ND/FU	UO 12.000 ND/FU
Code No.		381447	381457	381207	381467	381477	381487	381497
Control		RO 1000						
<b>Feed water specification</b>								
Feed water pressure min./max.	bar	2/6						
Pressure fluctuations (limit)	bar	± 0,5						
Temperature min./max.	°C	5/35						
<b>Connections</b>								
Feed water	DN	32	40	40	40	50	50	50
Permeate	DN	32	32	40	40	40	50	50
Concentrate	DN	32	32	32	32	32	32	50
Power consumption	kW	5,5			7,5	11		
Power connection	V/Hz	3x400/50						
Protection type		IP 54						
<b>Output data</b>								
Permeate outlet max.	l/h	4300	5400	6000	7000	8000	9500	12000
Concentrate min.	l/h	1430	1800	2000	2330	2660	3160	4000
Concentrate backflow	l/h	3500	3100	2700	2700	2200	1300	2700
Pump pressure max.	bar	25						
Permeate counterpressure max.	bar	0,3, without permeate backflow						
Recovery	%	75						
Salt rejection rate	%	97						
<b>Dimensions and weights</b>								
Dimensions (HxWxD)	mm	1800x2800x750	1800x2800x750	1800x3800x750	1800x3800x750	1850x3800x800	1850x4800x800	1850x3900x800
Weight approx.	kg	450	500	600	600	700	800	900
<b>Environmental data</b>								
Max. ambient temperature	°C	40						
Relative humidity (air)	%	<95, non-condensing						

Systems are designed for softened drinking water without chlorine in accordance with the German Drinking Water Regulation with a salt content of 1000 mg/l and at a feed water temperature of 15°C.

## 2. Usage limits



In order to attain the life span of 3 years calculated for the membranes, reverse osmosis installations must be supplied, in accordance with the installation type, with softened water (types ND, KR, e.g.) or tap water with stabilised hardness level (type AS, e.g.) and run in compliance with the German Drinking Water Regulation and the specifications below. Membranes are wearing parts. The degree of wear depends on the feed water quality and the operating conditions.

Parameter	Unit	Limit
Free chlorine *	mg/l	not detectable*
Iron **	mg/l	0.2
Manganese **	mg/l	0.05
Silicate ***	mg/l	25
SDI <sup>4</sup>	-	3
pH level during operation <sup>5</sup>		3.6-9.5
pH level during cleaning		2-12

The feed water must be free from substances that damage the membrane. These are in particular:

- oxidants (e.g. free chlorine, ozone, hydrogen peroxide)
- surfactants (especially if cationic)
- biocides and inhibitors
- natural organic matter (NOM)

Additionally, the operating parameters for the reverse osmosis installations given in chapter C (Technical Data) apply.

If the UP feed water is softened, the soft water quality is to be observed. If antiscalant is added for hardness stabilisation (i.e. when iron, manganese and silicate are stabilised at the same time), the manufacturer's specifications must be complied with. If necessary, the pH or the permeate output must be adjusted.

\* Free chlorine (oxidants) corrodes the plastic membrane, especially if metal ions are present. This attack is irreversible and will cause a decrease of the salt retention rate while increasing the permeate conductance. This is why the feed water of the UP installation should not contain any free chlorine.

\*\* Iron/manganese can be present in a dissolved or undissolved state. Undissolved iron or manganese should be removed by filtration. Dissolved iron/manganese can be oxidised and then removed by filtration or stabilised, for example, by means of an antiscalant. Iron/manganese deposits on the membranes can generally be removed by chemical cleaning.

\*\*\* Silicate may form solid deposits on the membranes which are hard to remove. The maximum silicate concentration in the RO concentrate should not exceed 100 mg/l if soft water is used. In RO installations, type KR, the maximum silicate concentration in the RO feed water is 10 mg/l for this reason.

<sup>4</sup> The SDI is a sum parameter. It indicates the degree to which suspended matter will likely form deposits on the membrane. If the SDI > 3, prefiltration must be improved accordingly.

<sup>5</sup> The pH level considerably influences the solubility of many water compounds. It may be necessary to modify the pH level in order to obtain the desired permeate yield or quality.

### 3. Product description

#### 3.1 Rating plate

The rating plate is located on the front side of the system. It contains important information on the output and maximum operating parameters of the system.

To ensure fast and problem-free processing of warranty claims, technical information or customer service, be sure to indicate the system type, item number and manufacturing number!

#### 3.2 Working principle diagram

See the R+I diagram in the appendix

#### 3.3 Functional description

Softened feed water is fed in through a fine filter (5 µm filter unit) to the circuit pump unit. This unit pumps the water through the semipermeable membranes at high pressure. As a result of the high pressure, some of the water diffuses through the membranes. The result is purified water that is almost completely free of salts, colloids, germs and pyrogens. This water, which is led off, is referred to as the **permeate**. The salts that are held back are continually rejected into the wastewater channel with the **RO concentrate**.

To arrive at a more economical yield and to cause water to flow over the membranes optimally, part of the concentrate is directed back in front of the membranes.

### 3.4 Short description of the components

<b>Hardness monitoring device (1X02) (Option)</b>	Continuously monitors soft water quality and generates an alarm message if a limit value is exceeded.
<b>Pressure gauge filter inlet (1Pr01)</b>	Display of the inlet pressure.
<b>Fine filter (1F01)</b>	Protects the RO membranes from impurities (filter fineness 5µm).
<b>Pressure gauge filter outlet (1Pr02)</b>	Display of filter outlet pressure.
<b>Sample removal tap for feed water (1V07)</b>	Used to remove samples from the feed water of the system.
<b>Inlet solenoid valve (1V01)</b>	Is always open during permeate production.
<b>Pressure switch (1Pr03)</b>	Monitors the inlet pressure.
<b>Pump (1P01)</b>	Produces the pressure required for the reverse osmosis process.
<b>Pressure gauge pump pressure (1PR04) (not installed in types FU)</b>	Display of the pump pressure.
<b>pump regulating valve (not installed in types FU)</b>	Used to adjust permeate outlet
<b>Pressure gauge operating pressure (1Pr05)</b>	Display of the operating pressure.
<b>Rinse connection, inlet (option 1V10)</b>	Makes it possible to connect to a cleaning station.
<b>Pressure gauge (concentrate pressure) (1Pr06)</b>	Display of the concentrate pressure.



<b>RO-module (1X01)</b>	Pressure vessel with membrane module.
<b>Rinse connection for concentrate (option 1V12)</b>	A 3-way ball cock used as a discharge for cleaning the system.
<b>Concentrate regulating valve (1V06)</b>	Used to set the amount of concentrate to be led away.
<b>Concentrate rinse valve (option 1V03)</b>	Used to force concentrate.
<b>Flow meter for concentrate (1FI01)</b>	Display of the RO concentrate quantity.
<b>pressure regulating valve (1V05)</b>	Controls the amount of concentrate directed in front of the pump.
<b>Flow meter for concentrate recirculation (1FI03)</b>	Display of the RO concentrate recirculation quantity
<b>Permeate measurement cell (1Q02)</b>	Measures the conductivity of the permeate. The control system is used to turn off the system if a limit value is exceeded.
<b>Permeate flow meter (1FI02)</b>	Displays the permeate flow level.
<b>Permeate rinse connection (option 1V11)</b>	A 3-way ball cock used as a discharge for cleaning the system.
<b>Control system</b>	Monitors and controls all important functions during the operation of the system.
<b>3.5 Options</b>	The options available for this installation/these installations are described in the P&I diagram and in the list of components in the appendix of this manual.

## Contents of Chapter D

1. Set-up .....	2
1.1 Requirements for the set-up location .....	2
1.2 Setting up the system .....	2
2. Water-side connections.....	3
2.1 Necessary qualifications of the assembly staff .....	3
2.2 Making the hydraulic connections.....	3
3. Electrical connection.....	4
3.1 Necessary qualifications of the assembly staff .....	4
3.2 Connecting the power supply.....	4
3.3 Connecting the accessories / signal exchange .....	4

### 1. Set-up

#### 1.1 Requirements for the set-up location

- The space required for the system may be derived from the measurements specified in Chapter C/21. In addition, there should be 1 m of space on each side available for operating and maintaining the system.
- The room in which the system is set up must meet the environmental conditions specified in Chapter C/2.
- The minimum bearing capacity at the set-up location must be 150% of the operating weight specified in Chapter C/2.
- The set-up surface must be even and run horizontally.
- The room must be well ventilated and not exposed to freezing temperatures.
- To avoid accumulation of spills caused by leaks, the area in which the system is set up must be equipped with a floor drain and/or a leak monitoring system and corresponding alarm.
- The necessary electrical connections must be available on the construction side (see Chapter C-1) and must be located no more than 2 m away from the system.

#### 1.2 Setting up the system

- ☞ Unpack the system.
- ☞ Check over the delivery for completeness and transport damage. (See Chapter C-3.2 for scope of delivery). Any deviations or damage must be reported to the manufacturer immediately.
- ☞ Move the system carefully to the place provided for it with a suitable lifting device.
- ☞ The system must be set up on a holding surface in accordance with the requirements of Chapter C/2.

## 2. Water-side connections

### 2.1 Necessary qualifications of the assembly staff



The water-side connection must only be made by trained professional staff members. Observe general regulations (in German-speaking countries, DIN, DVGW, SVGW and ÖKGW) as well as local installation requirements while installing the system.

### 2.2 Making the hydraulic connections

#### Inlet

- ☞ Remove the sealing disks from the screw connection in the inlet.
- ☞ Connect the inlet.

#### Permeate

- ☞ Remove the sealing disks from the screw connection in the permeate output.
- ☞ Connect the permeate output with the consumer line.

#### Concentrate

- ☞ Remove the sealing disk from the concentrate line.
- ☞ Connect the concentrate output with the drain



Caution

In standstill times of the system the max. back pressure of 0,3 bar must not be exceeded.

The cross section of permeate piping by customer may only be one nominal width greater than the permeate output piping of the system.

At a back pressure > 0,3 bar and the danger of permeate backflow, a check valve has to be installed into permeate piping.

It is only allowed to install a shut-off valve into permeate piping if also a relief valve is installed.

### 3. Electrical connection

#### 3.1 Necessary qualifications of the assembly staff



Danger

Electrical connection tasks may only be performed in Germany by an electrician certified by VDE in accordance with the applicable requirements.

#### 3.2 Connecting the power supply



Danger

Before connecting the power supply, make certain that the corresponding main switch is turned off!

- ☞ Make the power supply connection in the control cabinet with a fixed connection according to the circuit diagram.

#### 3.3 Connecting the accessories / signal exchange

Connections for the

- Product container level
- Forced stop
- Combined malfunction
- Dosing

should be made according to the circuit diagram.

## Contents of Chapter E

1. Placing the system in service.....	2
1.1 Qualifications of the commissioning staff .....	2
1. Rinsing out the preservative fluid .....	2
1.3 Adjusting the operating parameters.....	3
2. Taking the system out of service .....	3

## 1. Placing the system in service

### 1.1 Qualifications of the commissioning staff



The system must be placed in service by qualified professionals.



Before the system is placed in service, all screw connections must be retightened.

### 1.2 Rinsing out the preservative fluid



The preservative solution contains **1.5% sodium bisulfite and 20% glycerin**.

The preservation fluid should be drained out into the run-off channel in accordance with applicable regulations governing pouring and draining.

- ☞ Connect the product permeate with run-off channel
- ☞ Open valves 1V04, 1V05 and 1V06 completely
- ☞ Open feed water
- ☞ Set the system into operation (see Chapter F) **and rinse for minimum 30 minutes**



The higher permeate conductivity during the rinsing of the system can cause a shut down of the system. In this case quit the malfunction (see Chapter F) and continue rinsing.

### 1.3 Adjusting the operating parameters

- ☞ Adjust valve 1V04 to middle position (50% open)
- ☞ Adjust min. concentrate flow at 1FI01 (see chapter C/2) with valve 1V06
- ☞ Adjust concentrate backflow at 1FI03 (if existing - see Chapter C/2) with valve 1V05
- ☞ Adjust permeate flow at 1FI02 (see Chapter C/2) with valve 1V04
- ☞ If necessary readjust concentrate backflow (if existing) with 1V05 and concentrate flow with 1V06
  
- ☞ **Record the operating data of the system on a control sheet (see Chapter C/2)**
  
- ☞ Turn off the system
- ☞ Reconnect the permeate with the tank or consumer



**In no event should the values specified in the technical data for permeate output, yield, operating pressure and product output be exceeded.**



The permeate output of the system depends on the temperature of the feed water. For further information see Chapter 3.2.

## 2. Taking the system out of service



**Taking the system out of service refers to a down time of >30 days for the system.**  
**When the system is taken out of service, it must be pre-served.**  
**For information on preserving the system, please contact the manufacturer.**



**Contents of Chapter F**

- 1. Operating and display components .....2
  - 1.1. Operating elements for pumps with frequency converter (if existing) .....3
- 2. Operating states .....4
- 3. Short description of the RO 1000 control system.....5
  - 3.1. Operating structure .....5
  - 3.2. Functional diagram .....7
  - 3.3. Turning on.....8
  - 3.4. Turning off .....9

1. Operating and display components

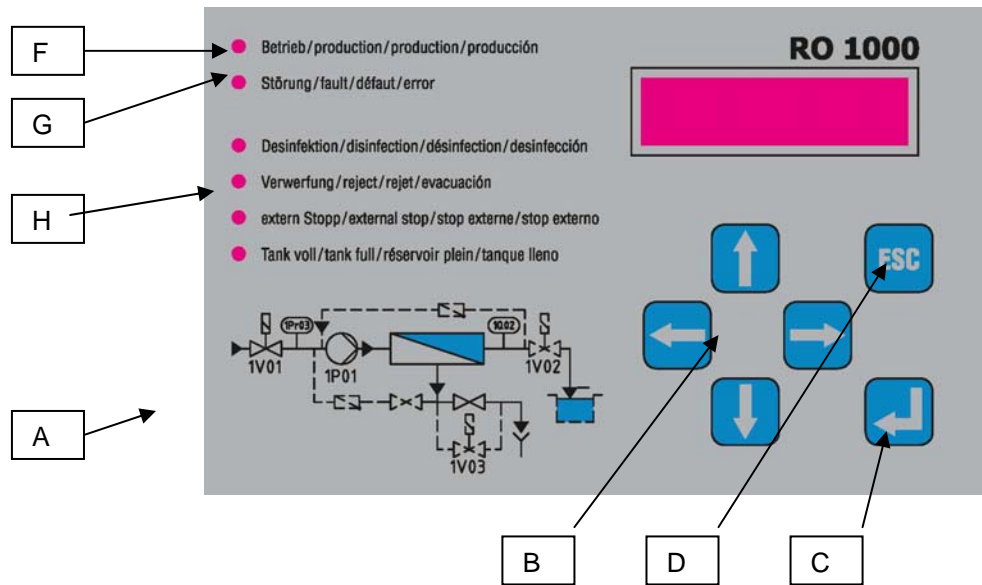

	Name	Function
A	Power switch	- Turns the system on and off → only with casing for top mounting
Q1	Main switch	- Turns the system on and off. → only with built-in casing
B		- Password entry - Menu selection - Selection
C		- Confirmation of entries - Brings up a menu
D		- Quit menu - Quit malfunctions
E	Display	Displays: - current operating state - permeate conductivity / temperature - operating hours - current malfunctions
F	Operation LED (green)	Continuous: → System in operation Flashing: Maintenance request
G	Malfunction LED (red)	Active malfunction
H	Operating states LEDs (yellow)	
	Disinfecting	Disinfecting active
	Rejection	Permeate rejection active
	Regeneration	<b>External stop</b> entry active Permeate production interrupted
	Tank full	<b>Upper level</b> input active Permeate production interrupted



For additional information on the function and operation of the RO 1000 control unit, please refer to the RO 1000 control unit manual in the appendix of these Operating Instructions.

1.1. Operating elements for pumps with frequency converter (if existing)

	Description	Function
▲	arrow key up	Increasing of permeate flow <b>Option PKR:</b> Increasing of setpoint value permeate flow
▼	arrow key down	Decreasing of permeate flow <b>Option PKR:</b> Decreasing of setpoint value permeate flow

## 2. Operating states

<b>Turned off</b>	System off (all outputs inactive) Malfunction recording off
<b>Operation</b> ⇒ <b>Rejection</b>	1V01 input valve opened, 1P01 pump in operation 1V02 permeate valve (when existing) closed Permeate is being rejected  <b>For RO-Types UO-ED:</b> 1V01 input valve opened, 1P01 pump in operation 1V02.2 valve closed, 1V02.1 valve opened Permeate is being rejected
⇒ <b>Production</b>	1V01 input valve opened, 1P01 pump in operation 1V02 permeate valve (when existing) opened System is producing permeate  <b>For RO-Types UO-ED:</b> 1V01 input valve opened, 1P01 pump in operation 1V02.2 valve opened System is producing permeate
⇒ <b>Concentrate rinsing</b>	1V01 input valve opened, 1V03 concentrated valve opened After a set amount of time elapses, switch over to <b>tank full</b>
⇒ <b>Tank full</b>	<b>Upper level</b> input (terminal 31, 32) opened System in standby until request about level active again
⇒ <b>Discont. rinsing</b>	Time-controlled forced production if the operating state <b>tank full</b> has been active for the set time
⇒ <b>External stop</b>	<b>External stop</b> input (terminal 23, 24) opened Permeate production interrupted until <b>External stop</b> input closed again
<b>Disinfection</b>	System in operation <b>without any safety devices</b> 1V01 input valve opened, 1P01 pump in operation 1V02 permeate valve (when existing) opened

### 3. Short description of the RO 1000 control system

**3.1. Operating structure** Operating and monitoring of the control system takes place on the following 2 levels

**Display level** Alternating display of:



- actual operating state

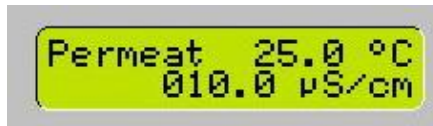

- permeate conductivity and temperature



- operating hours



- actual malfunctions

**Operating level**

To get into operation level press the Enter-key.



- Acknowledge Errors  
- Change of operation states



- Display of actual Permeate- conductivity and -temperature



- Display operating hours  
- Setting of Cond.-limits (operator password)



07 ps LIM exc.  
08 calibration

- Calibration of Cond.-permeate and T-permeate (operator password)
- Setting alarm options (operator password)



09 settings  
10 diagnostics

- Settings (operator password)
- Diagnosis (operator password)

### Operator password

1234



For additional information on the function and operation of the RO 100 control unit, please refer to the RO 1000 control unit manual in the Appendix of these Operating Instructions.

3.2. Functional diagram

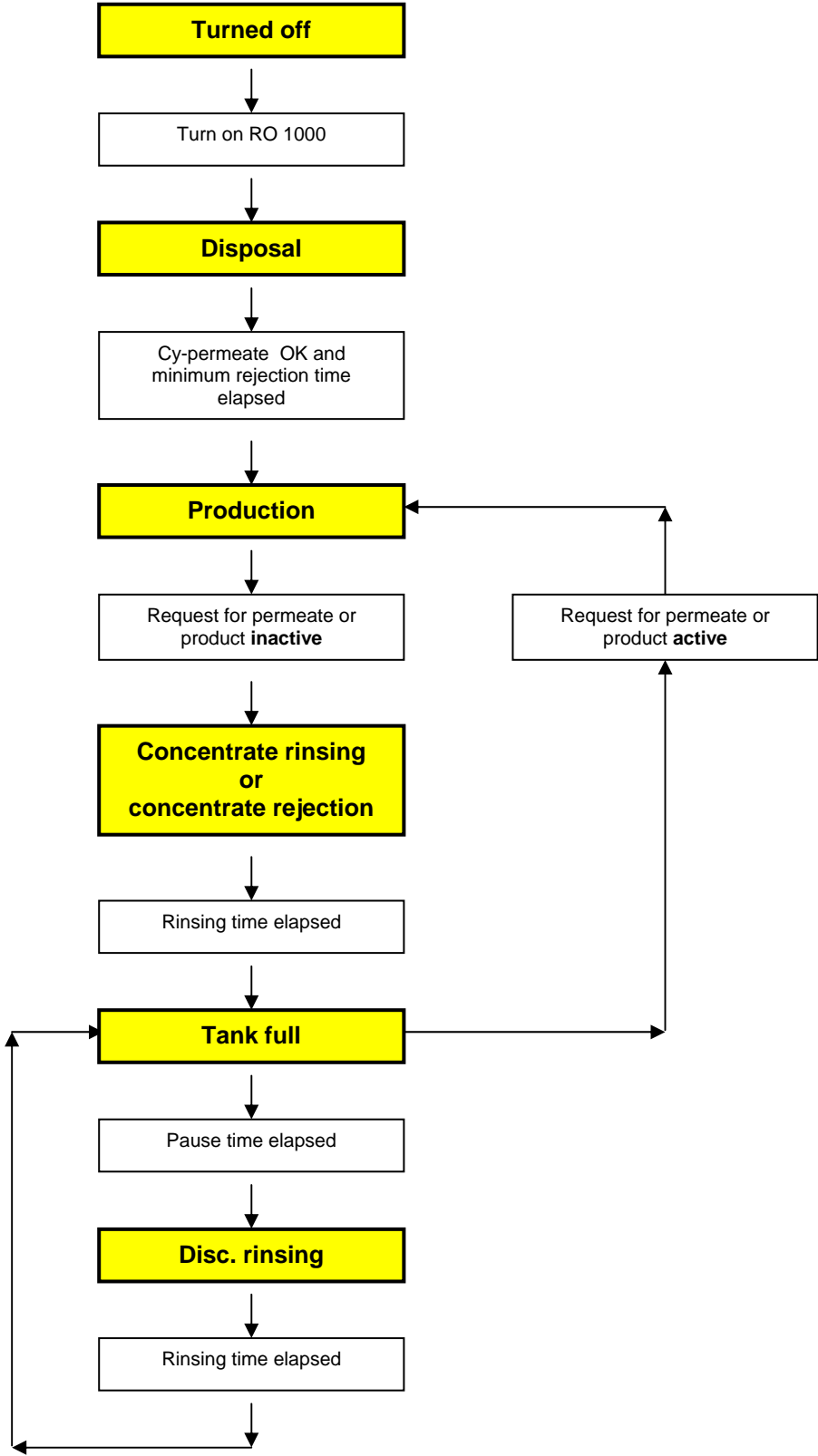

3.3. Turning on



```
01 Ackn.failure
2 Operat. mode
```



```
1 Ackn.failure
02 Operat. mode
```



```
Operation mode
STOP
```



```
Operation mode
OPERATION
```



```
Save?
Yes = ENTER
```



```
1 Ackn.failure
02 Operat. mode
```



→ System is running



3.4. Turning off



```

01 Ackn.failure
 2 Operat. mode
    
```



```

 1 Ackn.failure
02 Operat. mode
    
```



```

Operation mode
OPERATION
    
```



```

Operation mode
STOP
    
```



```

Save?
Yes = ENTER
    
```



```

 1 Ackn.failure
02 Operat. mode
    
```



→ System is shut-off

## Contents of Chapter G

1. General information .....	2
1.1. Malfunction message to the manufacturer .....	2
1.2. Malfunction display .....	2
1.3 Malfunction reset .....	2
1.4 Malfunction table .....	3

## 1. General information

The use of high-quality individual components and installing safety and monitoring equipment in our systems allows us to reach a very high level of operational availability.

If an operating malfunction should nevertheless arise, the error can easily be detected using the following malfunction table and the cause eliminated.

If serious malfunctions occur, please contact the manufacturer (see rating plate).

**Only qualified professional personnel with the appropriate training should eliminate malfunctions, taking into consideration the safety requirement in Chapter A of these Operating Instructions!**



**Power must be disconnected from the system before beginning these tasks, and the system must be protected to ensure it is not turned on again unintentionally!**

**Pressure must be released from all lines.**

### 1.1. Malfunction message to the manufacturer

To ensure effective help in resolving malfunctions, please have the following information on hand:

- Manufacturing number
- Item number
- System type
- Log sheets and maintenance sheets from the last 4 months

### 1.2. Malfunction display

- Red malfunction LED on the control system
- Malfunction message appears on the display

### 1.3 Malfunction reset

☞ **ESC**

Malfunction pump with frequency converter (if existing)

☞ **Switch off main switch**

### 1.4 Malfunction table

Malfunction	Cause	Remedy
Control display dark	Power supply interrupted	Make power supply connection
	Fuse SI1 defective - control type 230VAC: 630mA - control type 24VDC: 2A	Replace the fuse in question
	Fuse SI2 (6,3A) defective	
	Flat band cable between the motherboard and the display unplugged	Unscrew the front plate and plug the cable back in
	Control system defective	Replace the control system
<b>Motor/hard water</b> display:	Hard water sensor triggered (if present)	- Check the soft water quality - Check the sensor and replace if necessary
	Wire jumper defective	Restore the wire jumper
	Motor protection switch triggered (if present)	- Check the adjustment of the motor protection switch - Check the motor
<b>Low pressure</b> display: **	Feed water pressure too low	- Check the pressure difference on the softener - Increase the feed water pressure
	Filter blocked	Replace the filter cartridge
	Pressure switch defective	Replace the pressure switch
	1V01 input valve defective	Replace the valve
<b>CO exceeded</b> display:	Conductivity of feed water too high	Calculate desalinization rate Target: > 97%
	Desalinization rate too low	After consultation with the manufacturer: - Clean RO modules - Replace RO modules
<b>EEPROM fail</b> display:	Initialization error	Check parameters according to parameter overview (see control unit manual in the appendix of these Operating Instructions)
Malfunction LED is flashing:	System error	Replace the control system
System does not go into operation	<b>Tank full</b> LED is lit even though the permeate tank is empty	Level switch defective
	System in operation	Pump defective
	<b>Extrenal stop</b> LED is lit	Connected softener is in regeneration

\*\*

1V01 input valve opened, 1P01 pump not in operation

1V02 permeate valve (when existing) opened

If pressure returns, system restarts automatically after 1 min.

With every returning malfunction, restart time will be doubled to max. 32 min.

Time delay will be reset by pressing ESC-key

Malfunction	Cause	Remedy
Permeate output too low	Feed water temperature too low	Calculate permeate output according to Chapter A3.3
	Permeate counterpressure too high	Check permeate line
	Modules blocked	After consultation with the manufacturer: - Clean RO modules - Replace RO modules
	Pump defective	Replace pump
	Valve position changed	Re-adjust unit
	Frequency controlled pump runs too slow	Check adjustment of frequency controlled pump
Red LED at frequency controlled pump is illuminated/ is flashing	Malfunction of frequency controlled pump	- check motor - switch off main switch and switch on again

## Contents of Chapter H

1. Maintenance and monitoring tasks.....	2
1.1 Safety information .....	2
1.2 General information .....	2
2. Logging operating parameters.....	3
2.1 Performing a concentrate rinse (water brushing) .....	4
3. Maintenance .....	5
3.1 Maintenance tasks .....	5

## 1. Maintenance and monitoring tasks

### 1.1 Safety information



The operator must ensure that all maintenance, monitoring and assembly tasks are performed by authorized and qualified trained personnel.

The system must be shut down and protected from being placed in operation again unintentionally before all repair and maintenance tasks.



Before beginning tasks on the electrical systems and equipment, a check must confirm that power has been disconnected from the system. In addition, the system must be secured to prevent it from being turned on again unintentionally.

Protective clothing suitable for the hazard at hand must be worn while performing the maintenance tasks.

Immediately after the maintenance tasks are completed, all safety and protective equipment must be set back in place and functionality restored.

### 1.2 General information

To ensure long-term problem free operation of the system, maintenance tasks must be performed at regular intervals and a record must be kept of operating parameters!

The record of operating parameters and maintenance tasks should be kept by the operator of the system himself.



Signing a maintenance contract with the supplier makes it possible for the supplier to take over the responsibility of performing regular maintenance tasks on the system.

A record book should be kept to record operating parameters. It is located in the appendix of these operating instructions. The purpose of this record keeping is to have continuous documentation of the operating parameters. This makes it easier to detect a drop in output or incorrect functionality of the system and then to eliminate the problem.

The documentation of maintenance tasks should be kept on the maintenance log that is provided for this purpose.

## 2. Logging operating parameters

The following parameters must be checked and recorded **weekly**:

Parameter	Measurement point/remarks
Operating hours	Control display
Residual hardness in soft water	Check with the hardness kit on the 1V07 tap (not necessary by units of AS)
Conductivity of feed water	Verification with conductivity measurement device
Temperature of feed water	Verification with conductivity measurement device
Fine filter inlet pressure	1Pr01 pressure gauge
Fine filter outlet pressure	1Pr02 pressure gauge
Operating pressure (if existing)	1Pr05 pressure gauge
Concentrate pressure	1Pr06 pressure gauge
Permeate output	1FI02 flow meter
Concentrate output	1FI01 flow meter
Concentrate recirculation (if existing)	1FI03 flow meter
Conductivity of permeate	Control display
Temperature of permeate	Control display
Desalinization rate	For calculation see Chapter A 3.2
Absence of leaks in the system	



Minor fluctuations in the conductivity of the permeate and permeate output are normal. The effect of the temperature or a fluctuating conductivity may be reasons for this. When the desalinization rate drops below 97% or there is a drop in permeate output of about 10%, a concentrate rinse should be performed (see 2.1).



## 2.1 Performing a concentrate rinse (water brushing)

During a concentrate rinse, the increase in the flow of concentrate flows more strongly through the membrane(s). Because of this, soluble accretions are more readily removed and rinsed away.

The duration of a "water brushing" should be at least 60 minutes, and it should be performed as follows:

- ☞ Log record of actual values
- ☞ Open the 1V06 concentrate valve
- ☞ Open the 1V05 pressure control valve
- ☞ Allow to rinse for at least 60 minutes
- ☞ Adjust the operating parameters to the target values
- ☞ Log record of actual values

### Note:

**If the conductivity of the permeate does not improve permanently after a concentrate rinsing, a chemical cleaning of the membranes must be performed.**

**In this case, it is essential to contact the supplier to agree upon the further procedure!**

### 3. Maintenance



Maintenance tasks should be performed when needed, but no less often than at the maintenance specified intervals!

#### 3.1 Maintenance tasks

The following maintenance task should be performed:

System part	Task to be performed	Maintenance interval
Fine filter	Replace the fine filter cartridges and clean the filter housing	-3 months -if the pressure drops by 0.8 bar
Pressure switch	Functional test by blocking off the feed water inlet  → RO must switch off	-6 months
Sensor hardness monitoring device (if any)	Replace sensor	- 12 months - after triggering of sensor
- Conductivity cell(s) - pH-sensor (if existing)	Check of parameters with reference device, if necessary new calibration	- on start-up - 1 year - if quality of feed water changes
Filter mat for control cabinet fan (if any)	Check fouling factor and clean as required	- 1 month
	Replace filter mat	- 6 month
Accessories	see Operating Instructions in the appendix	

**Log sheet**

Customer: \_\_\_\_\_  
 \_\_\_\_\_  
 \_\_\_\_\_

System Type: \_\_\_\_\_  
 Item No.: \_\_\_\_\_  
 Placed in service on: \_\_\_\_\_

Date	Value R+I/ Measuring point	Value	Values when placed in service	Date	Date	Date	Date
Operating hours	Display Control	h					
Residual hardness of soft water (not necessary by units of <b>AS</b> )	1V07	°dH					
Conductivity of feed water	1V07	µS/cm					
Temperature of feed water	1V07	°C					
Fine filter inlet pressure	1Pr01	bar					
Fine filter outlet pressure	1Pr02	bar					
Operating pressure	1Pr04	bar					
Concentrate pressure	1Pr05	bar					
Permeate output	1Pr06	l/h					
Concentrate output	1FI02	l/h					
Concentrate recirculation (if existing)	1FI01	l/h					
Conductivity of permeate	1FI03	µS/cm					
Temperature of permeate	Display Control	°C					
Desalination rate	Display Control	%					
Absence of leaks in the system	-						

**Note:** The values when placed in service must be entered when the system is placed in service.  
 After that, this log sheet should be duplicated. As described in chapter H, the operating parameters should be documented weekly.  
 If there is a significant deviation in actual values from the values when placed in service, the operator should contact the supplier and if appropriate send this log to the supplier as well.

**Maintenance log**

Customer: \_\_\_\_\_  
 \_\_\_\_\_  
 \_\_\_\_\_

System type: \_\_\_\_\_

Item No.: \_\_\_\_\_

Placed in service on: \_\_\_\_\_ CW \_\_\_\_\_

1. Quarter / year: \_\_\_\_\_

System part	CW 1	CW 2	CW 3	CW 4	CW 5	CW 6	CW 7	CW 8	CW 9	CW 10	CW 11	CW 12	CW 13
Fine filter													
Pressure switch													
Sensor hardness monitoring device													
Conductivity cell pH-sensor (if existing)													
Filter mat for control cabinet fan (if any)													
Accessories													

**Note: Each maintenance task should be documented with a date and the initials of the person performing the task.  
 Copies should be made of the maintenance log before the first entries are made!**

**Maintenance log**

Customer: \_\_\_\_\_  
 \_\_\_\_\_  
 \_\_\_\_\_

System type: \_\_\_\_\_

Item No.: \_\_\_\_\_

Placed in service on: \_\_\_\_\_ CW \_\_\_\_\_

2. Quarter / year: \_\_\_\_\_

System part	CW 14	CW 15	CW 16	CW 17	CW 18	CW 19	CW 20	CW 21	CW 22	CW 23	CW 24	CW 25	CW 26
Fine filter													
Pressure switch													
Sensor hardness monitoring device													
Conductivity cell pH-sensor (if existing)													
Filter mat for control cabinet fan (if any)													
Accessories													

**Note: Each maintenance task should be documented with a date and the initials of the person performing the task. Copies should be made of the maintenance log before the first entries are made!**

**Maintenance log**

Customer: \_\_\_\_\_  
 \_\_\_\_\_  
 \_\_\_\_\_

System type: \_\_\_\_\_  
 Item No.: \_\_\_\_\_  
 Placed in service on: \_\_\_\_\_ CW \_\_\_\_\_

3. Quarter / year: \_\_\_\_\_

System part	CW 27	CW 28	CW 29	CW 30	CW 31	CW 32	CW 33	CW 34	CW 35	CW 36	CW 37	CW 38	CW 39
Fine filter													
Pressure switch													
Sensor hardness monitoring device													
Conductivity cell pH-sensor (if existing)													
Filter mat for control cabinet fan (if any)													
Accessories													

**Note: Each maintenance task should be documented with a date and the initials of the person performing the task.  
 Copies should be made of the maintenance log before the first entries are made!**

**Maintenance log**

Customer: \_\_\_\_\_  
 \_\_\_\_\_  
 \_\_\_\_\_

System type: \_\_\_\_\_  
 Item No.: \_\_\_\_\_  
 Placed in service on: \_\_\_\_\_ CW \_\_\_\_\_

4. Quarter / year: \_\_\_\_\_

System part	CW 40	CW 41	CW 42	CW 43	CW 44	CW 45	CW 46	CW 47	CW 48	CW 49	CW 50	CW 51	CW 52	(KW 53)
Fine filter														
Pressure switch														
Sensor hardness monitoring device														
Conductivity cell pH-sensor (if existing)														
Filter mat for control cabinet fan (if any)														
Accessories														

**Note: Each maintenance task should be documented with a date and the initials of the person performing the task. Copies should be made of the maintenance log before the first entries are made!**

## Contents of chapter I

1. Preserving the system .....	2
1.1 General points .....	2
1.2 Preserving options .....	2
1.3 Materials required .....	2
1.4 Connecting the preservation tank .....	2
1.4.1 For systems without cleaning connections .....	2
1.4.2 For systems with cleaning connections (optional) .....	3
1.5 Preparing the preserving solution .....	3
1.6 Executing the preservation procedure .....	4
1.7 Composition of the preserving solution .....	4
2. Cleaning the system .....	5
2.1 General points .....	5
2.2 Materials required .....	5
2.3 Connecting the cleaning tank .....	5
2.4 Preparing the cleaning solution .....	6
2.5 Executing the cleaning procedure .....	6
2.6 Cleaning solutions .....	8
2.6.1 Acid cleaning .....	8
2.6.2 Alkali cleaning .....	8



## 1. Preserving the system

### 1.1 General points



After three months at most the preserving agent should be flushed out and replaced if necessary.

When the system is shut down for more than thirty days, it must be preserved.

When it is put into operation again, please follow the procedure described in chapter E of this operating manual.



The preserving solution contains 1.5% of sodium bisulphite and 20% of glycerine.

The preserving solution should be fed into the pipelines in accordance with the directives that apply in the given case.

### 1.2 Preserving options

- Sodium bisulphite: preserving without antifreeze
- Sodium bisulphite + glycerine: preserving with antifreeze, to a temperature of - 10° C

### 1.3 Materials required

- Preserving tank with pump and locking valve
- 3 connecting tubes
- Preserving/neutralisation chemicals: sodium bisulphite (art. no. 530014) and glycerine (art no. 530024)
- Protective clothing (goggles, gloves, apron)

### 1.4 Connecting the preservation tank

- ☞ Switch off system
- ☞ Close the feed water inlet

#### 1.4.1 For systems without cleaning connections

- ☞ Set up the preservation tank at a height greater than that of the system, so as to ensure that the preserving solution will flow into the RO system without any difficulty
- ☞ Close off the valve on the preservation tank
- ☞ Detach the permeate pipe and the concentrate pipe of the RO system

- ☞ The connecting tubes should be connected as follows:
  - Remove hexagon-cap after pressure gauge 1Pr05 and set up a tube connection to the pump of preservation tank.
  - Set up a tube connection between preservation tank and the concentrate outlet of the RO system.
  - Set up a tube connection between preservation tank and the permeate outlet of the RO.

#### 1.4.2 For systems with cleaning connections (optional)

- ☞ Set up the preservation tank at a height greater than that of the system, so as to ensure that the preserving solution will flow into the RO system without any difficulty
- ☞ Close off the valve on the preservation tank
- ☞ The connecting tubes should be connected as follows:
  - Connect preservation-pump with 1V10 cleaning connection
  - Set up a tube connection between preservation tank and 1V12 concentrate cleaning connection
  - Set up a tube connection between preservation tank and 1V11 permeate cleaning connection

#### 1.5 Preparing the preserving solution



Danger

##### **Danger of fumes!**

**In handling cleaning chemicals, please have regard to the general instructions for avoidance of accidents and to what is stated in the relevant safety data sheet.**

**When pouring the chemicals into the preservation tank, protective clothing should be worn – protective goggles, rubber gloves and rubber apron**

- ☞ Charge the preservation tank with a quantity of soft water as specified in the table (see 1.7, depending on the size of the system).
- ☞ Check that the connections are adequately sealed.
- ☞ Prepare the preserving solution by adding the chemicals (as shown on table) to the preservation tank.

**Important:**

**Chemicals should be added with caution – stir constantly!**

### 1.6 Executing the preservation procedure

- ☞ Put the three-way ball valves (1V11 and 1V12) in "Flushing" position\*
- ☞ Open the 1V10 tap\*
- ☞ Open the 1V06 concentrate control valve and the 1V05 pressure control valve completely
- ☞ Open the locking valve on the preservation tank
- ☞ Switch on preservation-pump
- ☞ Let the preserving solution circulate for ten minutes
- ☞ Switch off the preservation-pump
- ☞ Close the locking valve on the preservation tank
- ☞ Close the 1V10 tap\*
- ☞ Detach the tube connections
- ☞ Close off feed water input and permeate and concentrate outlets with sealing disks
- ☞ Dispose of preserving solution (see 1.1 "General points")

\* Only for systems with cleaning connections

### 1.7 Composition of the preserving solution

	Permeate output of the system l/h	Soft water supply l	Sodium bisulphite powder g	Glycerine l
Art. no.			530 014	530 024
Conc. of chemicals			97%	86,5%
	- 500	20	200	3,2
	550 - 1500	50	500	8,0
	1550 - 3500	100	1000	16,0
	3550 - 9500	200	2000	32,0
	9550 -12.000	250	2500	40,0
	12.050 - 17.000	300	3000	48,0
	17.050 – 20.000	400	4000	64,00
	20.050 - 30.000	500	5000	80,00



Warning

The pH value of the preserving solution is 4 or thereabouts.

## 2. Cleaning the system

### 2.1 General points

If the conductivity of the permeate rises by as much as 15%, or if the permeate output falls by as much as 10%, it is recommended that the membrane modules should be cleaned.

There is a distinction to be made between two types of cleaning:



- 1.) Acid cleaning to remove carbonate and iron deposits
- 2.) Alkali cleaning to remove organic impurities and silica scaling.

**Generally cleaning should be carried out in the following sequence:  
alkali → acid.**

**Please discuss the type of cleaning with the manufacturer before carrying it out.**



**Cleaning solution should be disposed with in adherence to the local or country-specific requirements!**

### 2.2 Materials required

- Cleaning tank with pump and locking valve
- Three connecting tubes
- Universal indicator paper, pH 0-14 (art. no. 630074)
- Cleaning/ neutralising chemicals (see 2.6 "Cleaning solutions")
- Conductivity measurement device for comparative measurement
- Protective clothing (goggles, gloves, apron)

### 2.3 Connecting the cleaning tank

☞ see section 1.4

## 2.4 Preparing the cleaning solution



Danger

### **Danger of fumes!**

**In handling cleaning chemicals, please have regard to the general instructions for avoidance of accidents and to what is stated in the relevant safety data sheet.**

**When pouring the chemicals into the cleaning tank, protective clothing should be worn – protective goggles, rubber gloves and rubber apron!**

- ☞ Charge the cleaning tank with the quantity of soft water specified in the table.
- ☞ Check that the connections are adequately sealed
- ☞ Prepare the cleaning solution by adding the chemicals (as shown on table 2.6) to the cleaning tank.

### **Important:**

**Chemicals should be added with caution – stir constantly!**

## 2.5 Executing the cleaning procedure

- ☞ Switch off the system
- ☞ Close the feed water inlet

### **Charging the system with the cleaning solution**

- ☞ Put three-way ball valves (1V11 and 1V12) in "Cleaning" position\*
- ☞ Open the 1V10 tap\*
- ☞ Open the 1V06 concentrate control valve and the 1V05 pressure control valve completely
- ☞ Open the locking valve on the cleaning tank
- ☞ Switch on pump of cleaning tank

### **Time needed for the cleaning solution to be effective**

- ☞ Let cleaning solution circulate for between **30 and 60 minutes**
- ☞ Switch off pump of cleaning tank
- ☞ Close locking valves on the cleaning tank
- ☞ Dispose of cleaning solution (see 1.1, "General points")
- ☞ Close 1V10 tap\*
- ☞ Detache tube connection between cleaning tank and RO system
- ☞ Screw down again the hexagon cap

### Flushing out the system

- ☞ Open feed water inlet
- ☞ Switch on the RO system (see control manual)
- ☞ Flush out the system for **at least 45 minutes**. Here the flushing liquid that emerges should be disposed of a quantity at a time (see 1.1, "General points")
- ☞ Switch off RO system (see control manual)
- ☞ Detach the connecting tubes
- ☞ Reconnect permeate and concentrate outlets
- ☞ Put the 1V11 and 1V12 taps back into operating position\*



**Do not terminate the cleaning procedure until the pH value of the concentrate is the same as the pH value of the feed water.**

\* Only for systems with cleaning connections



The temperature of the cleaning solution must not exceed 35° C!  
If the pH value shows no further change between the input and outflow of the cleaning solution, the cleaning procedure may be terminated.

## 2.6 Cleaning solutions

### 2.6.1 Acid cleaning

			<b>Cleaning option 1</b>	<b>Cleaning option 2</b>
	Permeate output of the system l/h	Soft water supply l	Citric acid powder kg	Hydrochloric acid ml
Art. no.			530 015	530 13
Conc. of chemicals			100%	33%
	- 500	50	1,0	250
	550 - 1500	100	2,0	500
	1550 - 3500	200	4,0	1000
	3550 - 9500	300	6,0	1500
	9550 -12.000	400	8,0	2000
	12.050 - 17.000	500	10,0	2500
	17.050 – 20.000	700	14,0	3500
	20.050 - 30.000	1000	20,0	5000



The pH value of the preserving solution is 2 or thereabouts. It should not be allowed to fall below this level.

### 2.6.2 Alkali cleaning

			<b>Cleaning option 1</b>		<b>Cleaning option 2</b>
	Permeate output of the system l/h	Soft water supply l	NaOH-flakes g	Sodium dodecyl sulphate g	Genesol 703 kg
Art. no.			530 027	530 21	530 051
Conc. of chemicals			100%	90%	-
	- 500	50	50	15	1,25
	550 - 1500	100	100	30	2,50
	1550 - 3500	200	200	60	5,00
	3550 - 9500	300	300	90	7,50
	9550 -12.000	400	400	120	10,00
	12.050 - 17.000	500	500	150	12,50
	17.050 – 20.000	700	700	210	17,50
	20.050 - 30.000	1000	1000	300	25,00



The pH value of the preserving solution is 12 or thereabouts. It should not be allowed to fall below this level.

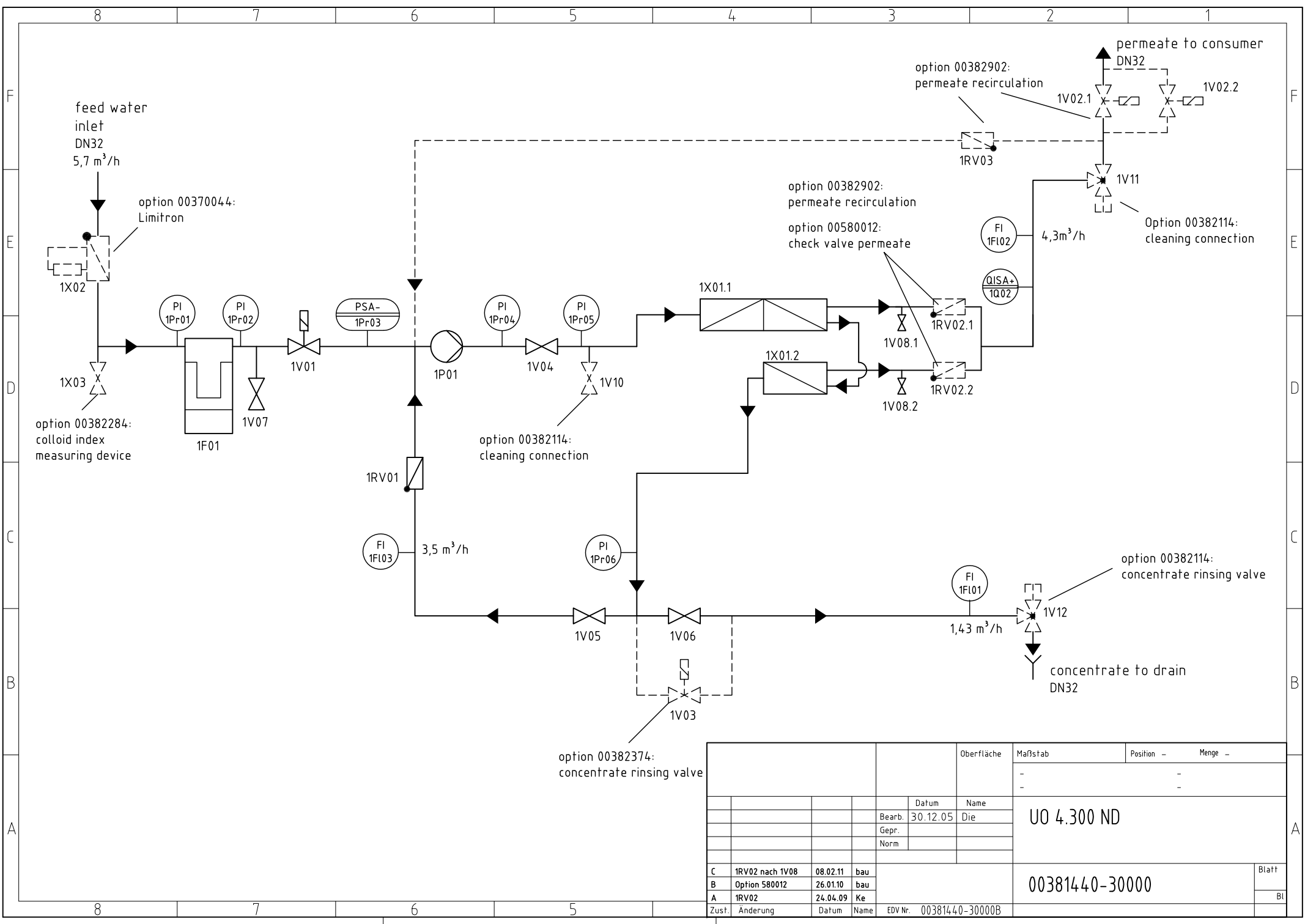

				Oberfläche	Maßstab	Position	Menge
					-	-	-
				Datum	Name		
				Bearb.	30.12.05	Die	
				Gepr.			
				Norm			
C	1RV02 nach 1V08	08.02.11	bau				
B	Option 580012	26.01.10	bau				
A	1RV02	24.04.09	Ke				
Zust.	Änderung	Datum	Name	EDV Nr.	00381440-30000B		
						Blatt	
						00381440-30000	
						Bl	



<b>UO 4.300 ND</b>		<b>Component List</b>	
Code-No. 00 381 440			
<b>P+I-No.</b>	<b>Code-No.</b>	<b>Description</b>	
1F01	00 330 050 00 335 101	filter housing 10" Big Blue, 1 1/2" filter cartridge, 10", 5 µm	
1FI01	00 580 044	flowmeter 500-5000 l/h	
1FI02	00 580 046	flowmeter 600-6400 l/h	
1FI03	00 580 043	flowmeter 400-4000 l/h	
1P01	00 390 341	pump CR 10-16, 3x400V/50Hz, 5,5KW	
1Pr01	00 630 006	pressure gauge, Ms, NG63, 1/4"h, 0-10 bar	
1Pr02	00 630 006	pressure gauge, Ms, NG63, 1/4"h, 0-10 bar	
1Pr03	00 600 012	pressure switch FF4-8, 3/8"	
1Pr04	00 630 008	pressure gauge, Ms, NG63, 1/4"h, 0-40 bar	
1Pr05	00 630 209	pressure gauge, Ms, NG63, 1/4"h, 0-25 bar	
1Pr06	00 630 209	pressure gauge, Ms, NG63, 1/4"h, 0-25 bar	
1Q02	00 100 011	conductivity measuring cell	
1RV01	00 580 012	check valve PVC, DN25, PN16	
1V01	00 410 102	solenoid valve, Ms, 1 1/4", DN32	
1V04	00 415 039	ball valve VA, DN40	
1V05	00 415 004	regulating valve- concentrate recirculation, ball valve VA, 3/4"	
1V06	00 415 056	concentrate regulating valve, needle valve VA, 1" IG	
1V07	00 410 084	sample	
1V08	00 405 050	sample	
1X01	00 400 049	vessel, GFK, 8040-2, 25 bar	
	00 400 048	vessel, GFK, 8040-1, 25 bar	
	00 395 151	low pressure element	
	00 545 399	electric control with	
	00 545 376	micro processor controller RO1000	
option 00382114 cleaning set:			
1V10	00 415 006	cleaning connection, ball valve VA, 1 1/4" IG	
1V11	00 405 324	3 way-ball valve, DN32	
1V12	00 405 324	3 way-ball valve, DN32	
option 00382902 permeate recirculation:			
1RV02.X	00 580 013	check valve PVC, DN25, PN16	
1RV03	00 580 013	check valve PVC, DN32, PN16	
1V02.1	00 405 117	solenoid valve DN21, 1"AG	
1V02.2	00 405 117	solenoid valve DN21, 1"AG	
option 00382374 concentrate rinse valve:			
1V03	00 410 126	solenoid valve Ms, 1", 230V/50Hz	
further optionen:			
1RV02.X	00 580 012	check valve PVC, DN25, PN16	
1X02	00 370 044	hardness monitor Limitron 11/4"	
1X03	00 382 284	colloid index measuring device	
	00 541 497	conductivity range permeate 0,5-50 µs/cm	
	00 541 498	conductivity range permeate 20-2.000 µs/cm	
	00 541 499	conductivity range permeate 100-10.000 µs/cm	

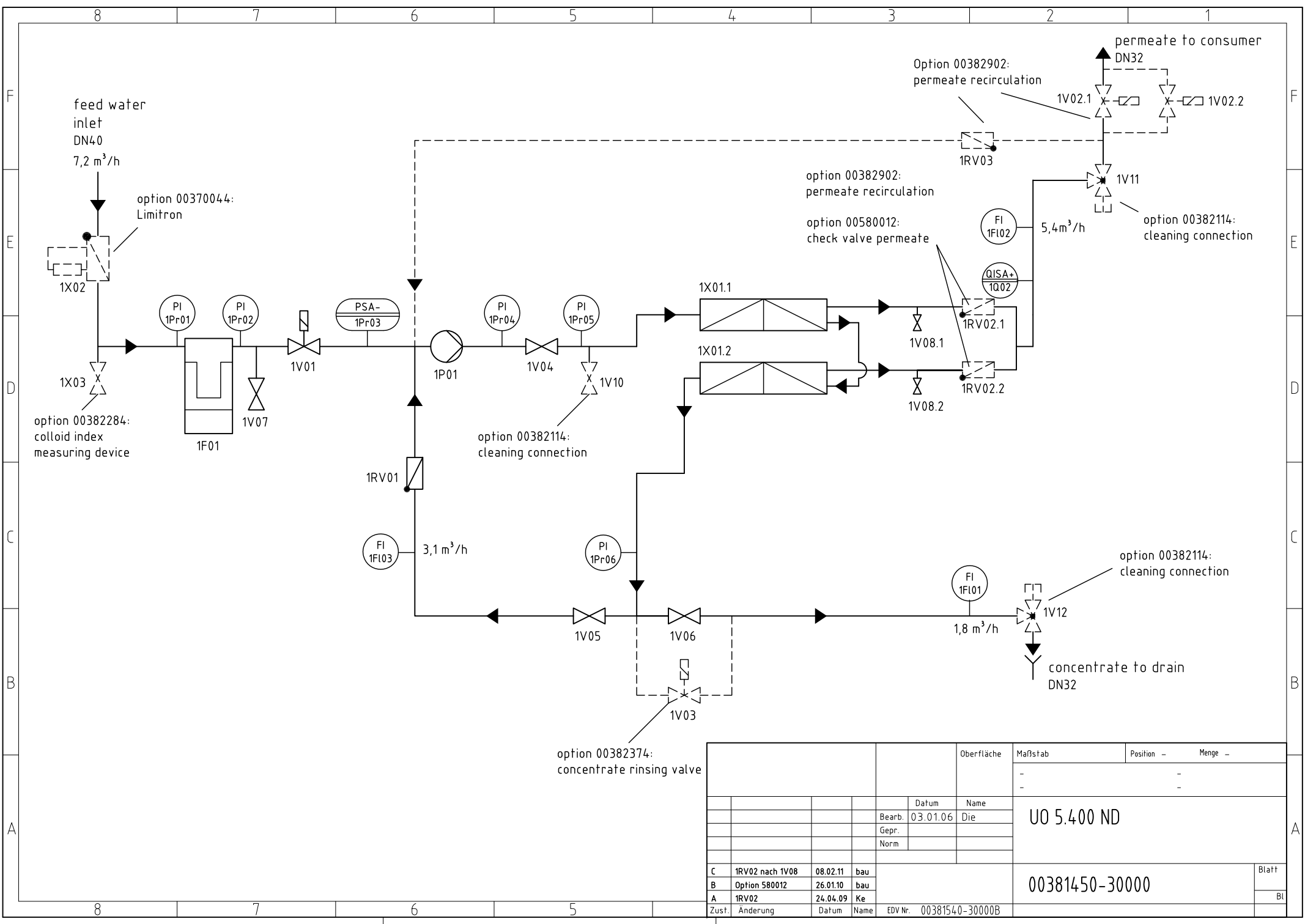

option 00382374:  
concentrate rinsing valve

				Oberfläche	Maßstab	Position	Menge
					-	-	-
				Datum	Name		
				Bearb.	03.01.06	Die	
				Gepr.			
				Norm			
C	1RV02 nach 1V08	08.02.11	bau				
B	Option 580012	26.01.10	bau				
A	1RV02	24.04.09	Ke				
Zust.	Änderung	Datum	Name	EDV Nr.	00381540-30000B		
						Blatt	
						00381450-30000	
						Bl	

<b>UO 5.400 ND</b> Code-No. 00381450		<b>Component List</b>	
<b>P+I-No.</b>	<b>Code-No.</b>	<b>Description</b>	
1F01	00 300 004 00 335 017	filter housing FMC3-2, 11/2" filter cartridge 20", 5 µm, 3 piece	
1FI01	00 580 044	flowmeter 500-5000 l/h	
1FI02	00 580 046	flowmeter 600-6400 l/h	
1FI03	00 580 043	flowmeter 400-4000 l/h	
1P01	00 390 339	pump CR 10-14, 3x400V/50Hz, 5,5KW	
1Pr01	00 630 006	pressure gauge Ms, NG63, 1/4"h, 0-10 bar	
1Pr02	00 630 006	pressure gauge Ms, NG63, 1/4"h, 0-10 bar	
1Pr03	00 600 012	pressure switch FF4-8, 3/8"	
1Pr04	00 630 008	pressure gauge Ms, NG63, 1/4"h, 0-40 bar	
1Pr05	00 630 209	pressure gauge Ms, NG63, 1/4"h, 0-25 bar	
1Pr06	00 630 209	pressure gauge Ms, NG63, 1/4"h, 0-25 bar	
1Q02	00 100 011	conductivity measuring cell	
1RV01	00 580 012	check valve PVC, DN25, PN16	
1V01	00 410 102	solenoid valve Ms, 11/4", DN32	
1V04	00 415 039	ball valve VA, DN40	
1V05	00 415 004	regulating valve- concentrate recirculation, ball valve VA, 3/4"	
1V06	00 415 056	concentrate regulating valve, needle valve VA, 1" IG	
1V07	00 410 084	sample	
1V08	00 405 050	sample	
1X01	00 400 049 00 395 136	vessel, GFK, 8040-2, 25 bar low pressure element	
	00 545 399 00 545 376	electric control with micro processor controller RO1000	
option 00382114 cleaning set:			
1V10	00 415 006	cleaning connection, ball valve VA, 11/4" IG	
1V11	00 405 324	3 way-ball valve, DN32	
1V12	00 405 324	3 way-ball valve, DN32	
option 00382902 permeate recirculation:			
1RV02.X	00 580 013	check valve PVC, DN25, PN16	
1RV03	00 580 013	check valve PVC, DN32, PN16	
1V02.1	00 405 117	solenoid valve DN21, 1"AG	
1V02.2	00 405 117	solenoid valve DN21, 1"AG	
option 00382374 concentrate rinse valve:			
1V03	00 410 126	solenoid valve Ms, 1", 230V/50Hz	
further optionen:			
1RV02.X	00 580 013	check valve PVC, DN25, PN16	
1X02	00 370 044	hardness monitor Limitron 11/4"	
1X03	00 382 284	colloid index measuring device	
	00 541 497	conductivity range permeate 0,5-50 µs/cm	
	00 541 498	conductivity range permeate 20-2.000 µs/cm	
	00 541 499	conductivity range permeate 100-10.000 µs/cm	

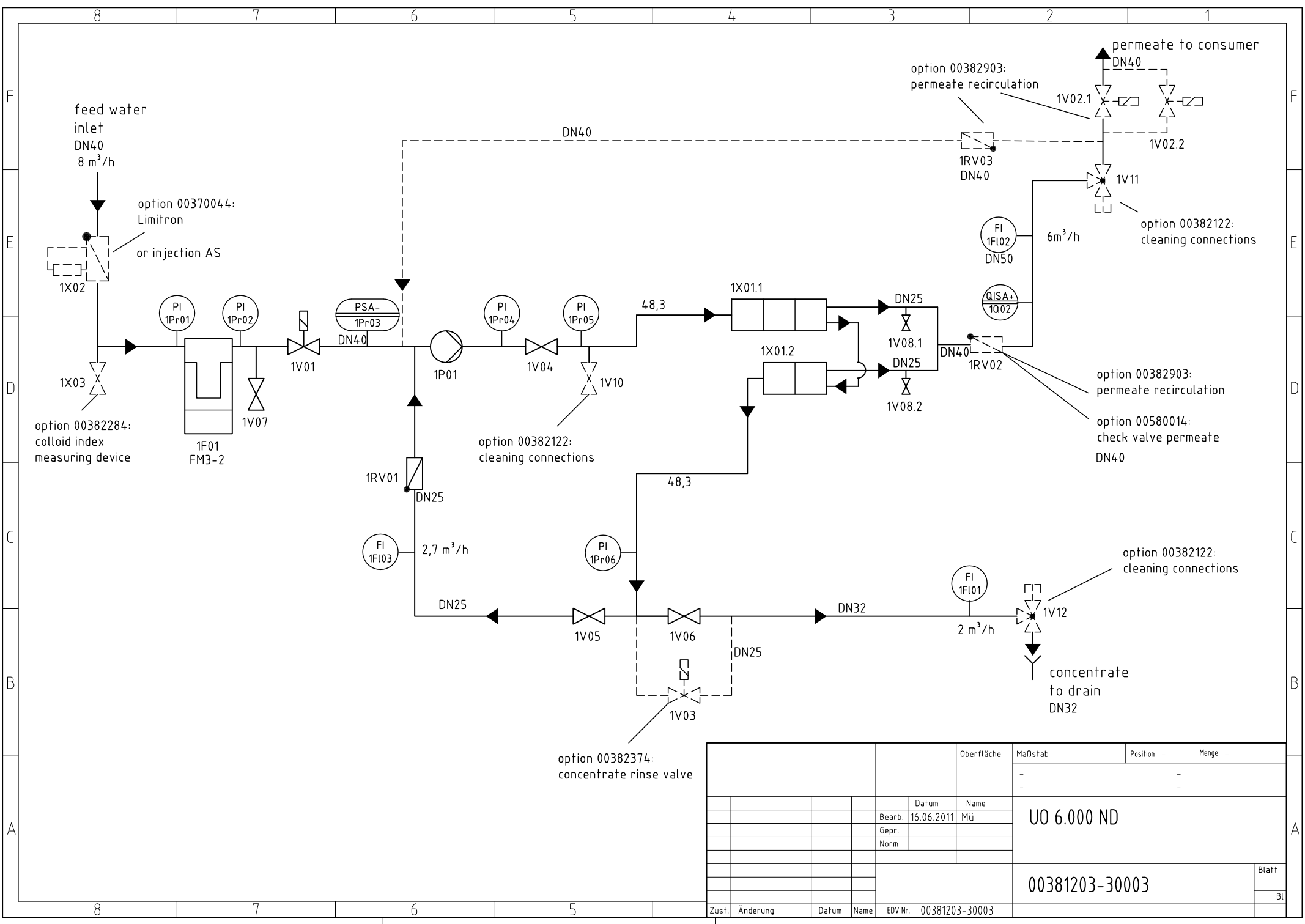

		Oberfläche	Maßstab	Position	Menge
		Datum	Name		
		Bearb.	16.06.2011	Mü	
		Gepr.			
		Norm			
				UO 6.000 ND	
				00381203-30003	
				Blatt	
				Bl	
Zust.	Änderung	Datum	Name	EDV Nr.	00381203-30003

<b>UO 6.000 ND</b> Code-No. 00381203		<b>Component List</b>	
<b>P+I-No.</b>	<b>Code-No.</b>	<b>Description</b>	
1F01	00 300 004 00 335 017	filter housing FMC3-2, 11/2" filter cartridge, 20", 5 µm, 3 pieces	
1FI01	00 580 044	flowmeter concentrate, 500-5000 l/h	
1FI02	00 580 046	flowmeter permeate 600-6400 l/h	
1FI03	00 580 043	flowmeter concentrate recirculation 400-4000 l/h	
1P01	00 390 341	pump CR 10-16, 3x400V/50Hz, 5,5KW	
1Pr01	00 630 006	pressure gauge filter inlet, NG63, 1/4"h, 0-10 bar	
1Pr02	00 630 006	pressure gauge filter outlet, NG63, 1/4"h, 0-10 bar	
1Pr03	00 600 012	pressure switch FF4-8, 3/8"	
1Pr04	00 630 008	pressure gauge pump pressure, NG63, 1/4"h, 0-40 bar	
1Pr05	00 630 209	pressure gauge operation pressure, NG63, 1/4"h, 0-25 bar	
1Pr06	00 630 209	pressure gauge concentrate pressure, NG63, 1/4"h, 0-25 bar	
1Q02	00 100 011	conductivity measuring cell permeate	
1RV01	00 580 012	check valve PVC, DN25, PN16	
1V01	00 410 102	solenoid valve, 11/4", DN32	
1V04	00 415 039	ball valve VA, DN40	
1V05	00 415 004	regulating valve - concentrate recirculation, ball valve 3/4"	
1V06	00 415 056	concentrate regulating valve, needle valve 1"	
1V07	00 410 084	sample	
1V08	00 405 050	sample permeate	
1X01	00 400 050	vessel, GFK, 8040-3, 25 bar	
	00 400 049	vessel, GFK, 8040-2, 25 bar	
	00 395 151	membrane element	
	00 545 399 00 545 376	electric control with micro processor controller RO1000	
option 00382122 cleaning set:			
1V10	00 415 006	cleaning connection, ball valve, 11/4"	
1V11	00 405 325	3-way ball valve DN40	
1V12	00 405 324	3-way ball valve DN32	
option 00382903 permeate recirculation:			
1RV02	00 580 014	check valve PVC, DN40, PN16	
1RV03	00 580 014	check valve PVC, DN40, PN16	
1V02.1	00 405 117	solenoid valve DN21, 1"AG	
1V02.2	00 405 117	solenoid valve DN21, 1"AG	
option 00382374 concentrate rinse valve			
1V03	00 410 126	solenoid valve, 1", 230V/50Hz	
further options:			
1RV02	00 580 014	check valve PVC, DN40, PN16	
1X02	00 370 070	hardness monitor Limitron 11/2"	
1X03	00 382 284	colloid index measuring device	

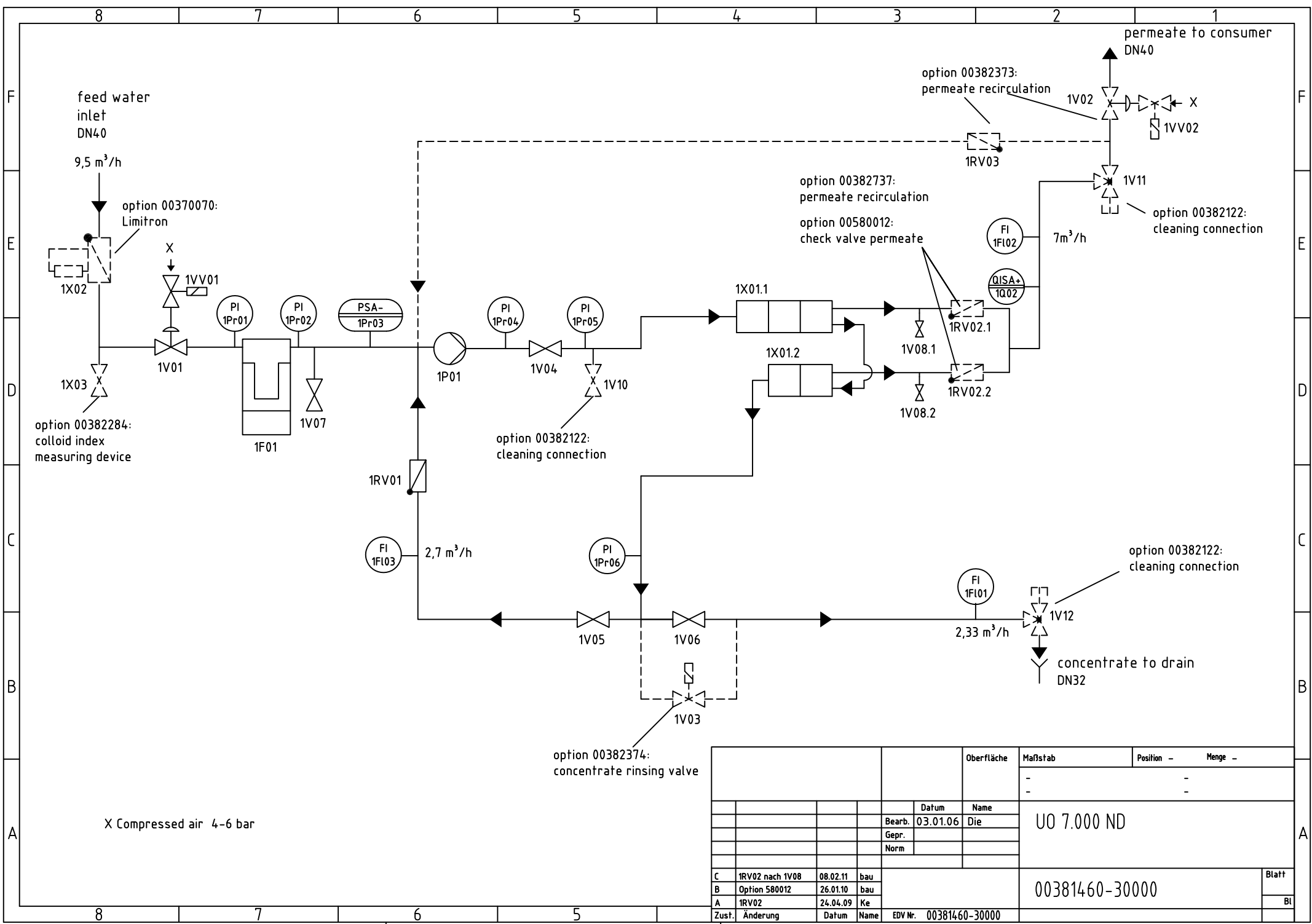

X Compressed air 4-6 bar

				Oberfläche	Maßstab	Position -	Menge -	
					-	-	-	
				Datum	Name	UO 7.000 ND		
				Bearb.	03.01.06	Die		
				Gepr.				
				Norm				
C	1RV02 nach 1V08	08.02.11	bau	00381460-30000				Blatt
B	Option 580012	26.01.10	bau					
A	1RV02	24.04.09	Ke					
Zust.	Änderung	Datum	Name	EDV Nr.	00381460-30000			Bl

<b>UO 7.000 ND</b> Code-No. 00381460		<b>Component List</b>	
<b>P+I-No.</b>	<b>Code-No.</b>	<b>Description</b>	
1F01	00 300 021 00 335 067	filter housing FMC3-3S flange DN 50 filter cartridge 30", 5 µm, 3 piece	
1FI01	00 580 044	flowmeter 500-5000 l/h	
1FI02	00 580 047	flowmeter 1-10 m³/h	
1FI03	00 580 043	flowmeter 400-4000 l/h	
1P01	00 390 345	pump CR 10-20, 3x400V/50Hz, 7,5KW	
1Pr01	00 630 006	pressure gauge Ms, NG63, 1/4"h, 0-10 bar	
1Pr02	00 630 006	pressure gauge Ms, NG63, 1/4"h, 0-10 bar	
1Pr03	00 600 012	pressure switch FF4-8, 3/8"	
1Pr04	00 630 008	pressure gauge Ms, NG63, 1/4"h, 0-40 bar	
1Pr05	00 630 209	pressure gauge Ms, NG63, 1/4"h, 0-25 bar	
1Pr06	00 630 209	pressure gauge Ms, NG63, 1/4"h, 0-25 bar	
1Q02	00 100 011	conductivity measuring cell	
1RV01	00 580 012	check valve PVC, DN25, PN16	
1V01	00 405 088	diaphragm valve DN40, pilote controlled, NC	
1V04	00 415 039	ball valve VA, DN40	
1V05	00 415 004	regulating valve- concentrate recirculation, ball valve VA, 3/4"	
1V06	00 415 056	concentrate regulating valve, needle valve VA, 1" IG	
1V07	00 410 084	sample	
1V08	00 405 050	sample	
1VV01	00 405 039	solenoid pilot valve, type 324, G¼", 230V/50Hz	
1X01	00 400 050	vessel GFK, 8040-3, 25 bar	
	00 400 049	vessel GFK, 8040-2, 25 bar	
	00 395 151	low pressure element 8040 ND	
	00 545 400	electric control with	
	00 545 376	micro processor controller RO1000	
option 00382122 cleaning set:			
1V10	00 415 006	cleaning connection, ball valve VA, 1 1/4" IG	
1V11	00 405 325	3 way-ball valve DN40	
1V12	00 405 324	3 way-ball valve DN32	
option 00382373 permeate recirculation:			
1RV02.X	00 580 012	check valve PVC, DN25, PN16	
1RV03	00 580 014	check valve PVC, DN40, PN16	
1V02	00 405 088	diaphragm valve DN40, pilote controlled, NC	
1VV02	00 405 039	solenoid pilot valve, type 324, G¼", 230V/50Hz	
option 00382374 concentrate rinse valve:			
1V03	00 410 126	solenoid valve Ms, 1", 230V/50Hz	
further optionen:			
1RV02.X	00 580 012	check valve PVC, DN25, PN16	
1X02	00 370 070	hardness monitor Limitron 11/2"	
1X03	00 382 284	colloid index measuring device	
	00 541 497	conductivity range permeate 0,5-50 µs/cm	
	00 541 498	conductivity range permeate 20-2.000 µs/cm	
	00 541 499	conductivity range permeate 100-10.000 µs/cm	

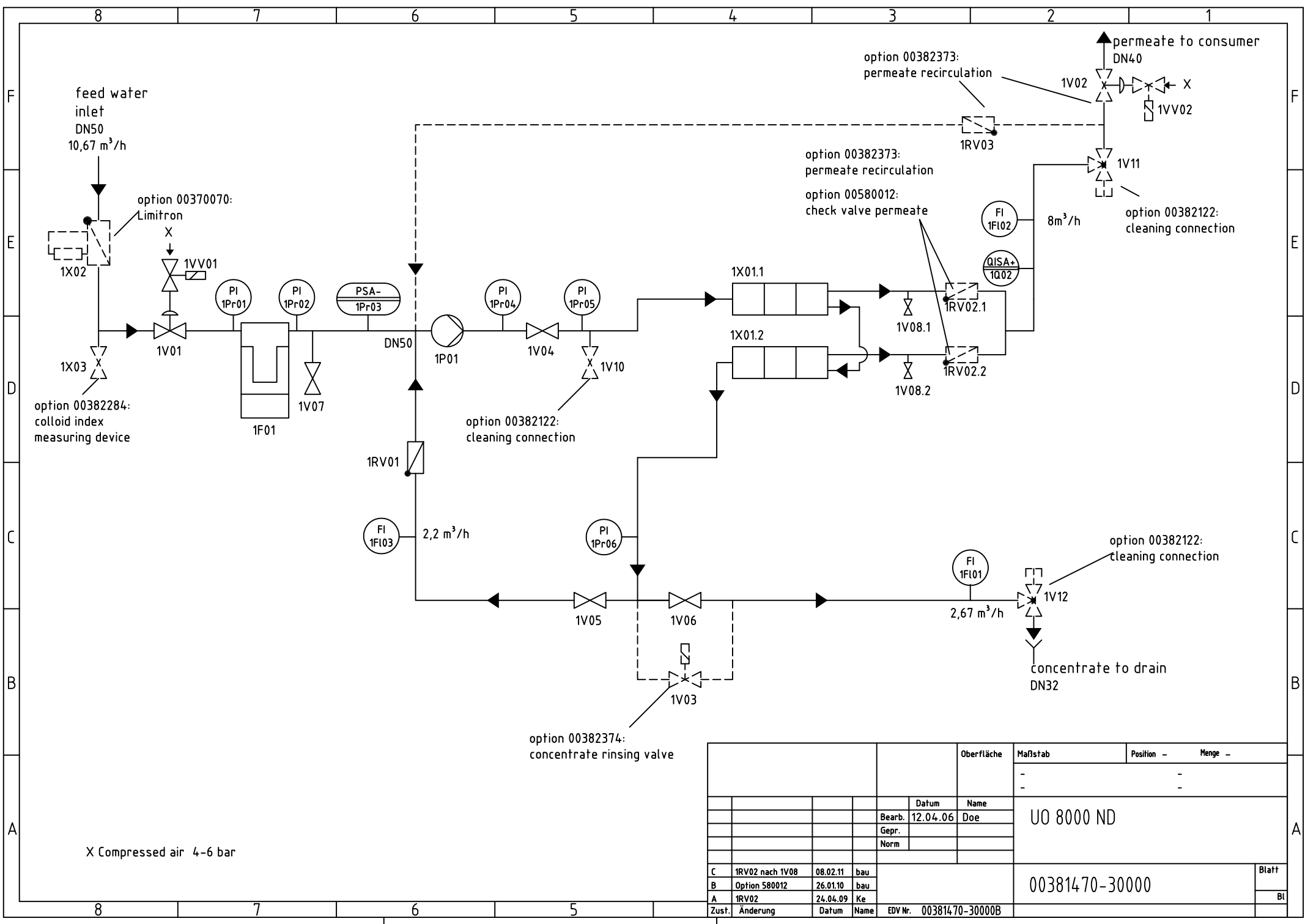

X Compressed air 4-6 bar

				Oberfläche	Maßstab	Position -	Menge -	
				Datum	Name	UO 8000 ND		
				Bearb.	12.04.06	Doe		
				Gepr.				
				Norm				
C	1RV02 nach 1V08	08.02.11	bau	00381470-30000				Blatt
B	Option 580012	26.01.10	bau					
A	1RV02	24.04.09	Ke					
Zust.	Änderung	Datum	Name	EDV Nr.	00381470-30000B			Bl



<b>UO 8000 ND</b> Code-No. 00381470		<b>Component List</b>	
<b>P+I-No.</b>	<b>Code-No.</b>	<b>Description</b>	
1F01	00 300 021 00 335 067	filter housing FMC3-3S, flange DN 50 filter cartridge 30", 5 µm, 3 piece	
1FI01	00 580 044	flowmeter 500-5000 l/h	
1FI02	00 580 047	flowmeter 1-10 m³/h	
1FI03	00 580 041	flowmeter 250-2500 l/h	
1P01	00 390 347	pump CR 15-10, 3x400V/50Hz, 11 KW	
1Pr01	00 630 006	pressure gauge Ms, NG63, 1/4"h, 0-10 bar	
1Pr02	00 630 006	pressure gauge Ms, NG63, 1/4"h, 0-10 bar	
1Pr03	00 600 012	pressure switch FF4-8, 3/8"	
1Pr04	00 630 008	pressure gauge Ms, NG63, 1/4"h, 0-40 bar	
1Pr05	00 630 209	pressure gauge Ms, NG63, 1/4"h, 0-25 bar	
1Pr06	00 630 209	pressure gauge Ms, NG63, 1/4"h, 0-25 bar	
1Q02	00 100 011	conductivity measuring cell	
1RV01	00 580 012	check valve PVC, DN25, PN16	
1V01	00 405 111	diaphragm valve DN50, pilote controlled, NC	
1V04	00 415 039	ball valve VA, DN40	
1V05	00 415 004	regulating valve- concentrate recirculation, ball valve VA, 3/4"	
1V06	00 415 056	concentrate regulating valve, needle valve VA, 1" IG	
1V07	00 410 084	sample	
1V08	00 405 050	sample	
1VV01	00 405 039	solenoid pilot valve, type 324, G¼", 230V/50Hz	
1X01	00 400 050	vessel GFK, 8040-3, 25 bar	
	00 395 136	low pressure element	
	00 545 401 00 545 376	electric control with micro processor controller RO1000	
option 00382122 cleaning set:			
1V10	00 415 006	cleaning connection, ball valve VA, 1 1/4" IG	
1V11	00 405 325	3 way-ball valve DN40	
1V12	00 405 324	3 way-ball valve DN32	
option 00382373 permeate recirculation:			
1RV02.X	00 580 014	check valve PVC, DN25, PN16	
1RV03	00 580 014	check valve PVC, DN40, PN16	
1V02	00 405 088	diaphragm valve DN40, pilote controlled, NC	
1VV02	00 405 039	solenoid pilot valve type 324, G¼", 230V/50Hz	
option 00382374 concentrate rinse valve:			
1V03	00 410 126	solenoid valve Ms, 1", 230V/50Hz	
further optionen:			
1RV02.X	00 580 014	check valve PVC, DN25, PN16	
1X02	00 370 070	hardness monitor Limitron 1 1/2"	
1X03	00 382 284	colloid index measuring device	
	00 541 497	conductivity range permeate 0,5-50 µs/cm	
	00 541 498	conductivity range permeate 20-2.000 µs/cm	
	00 541 499	conductivity range permeate 100-10.000 µs/cm	

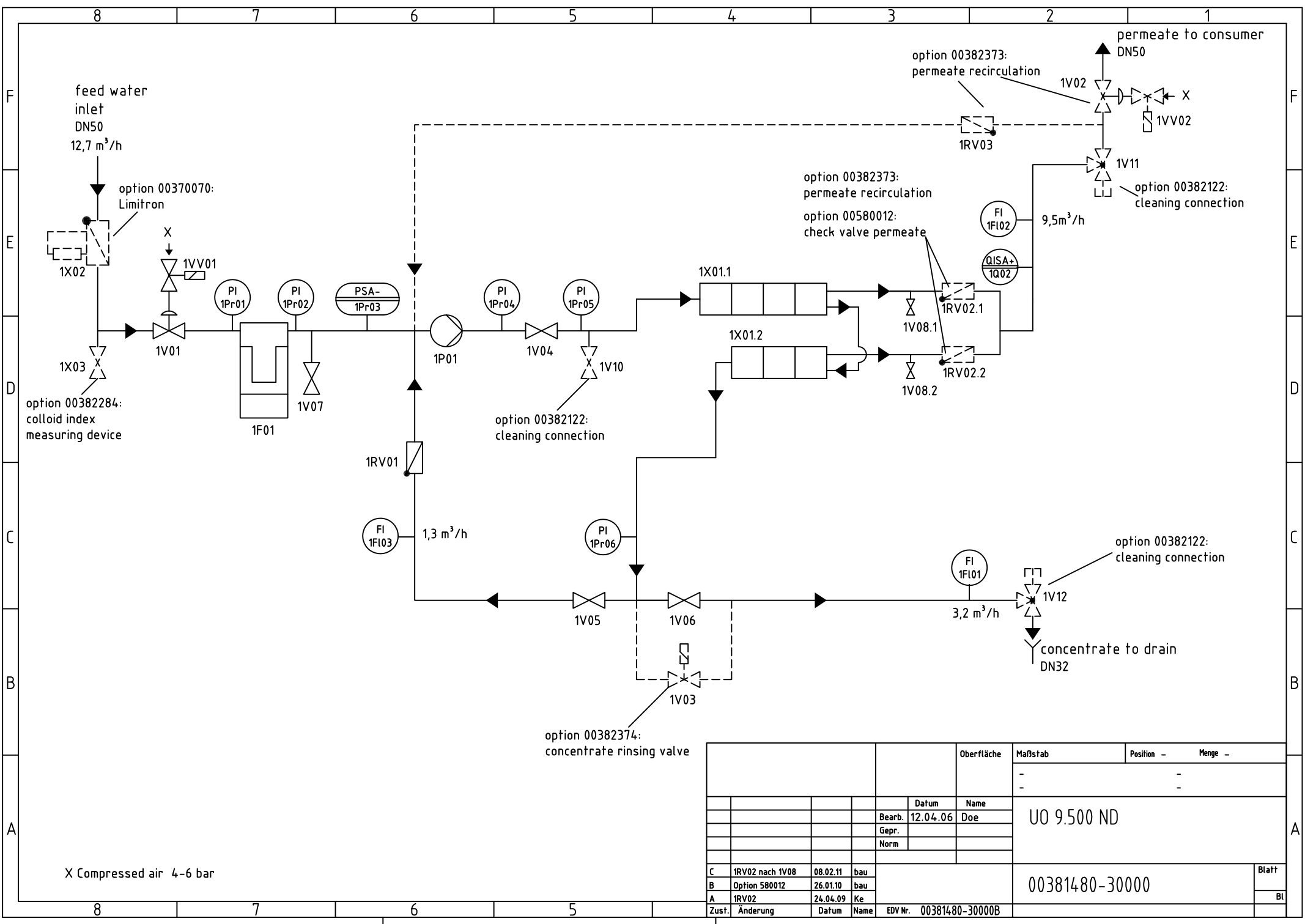

X Compressed air 4-6 bar

				Oberfläche	Maßstab	Position -	Menge -
					-	-	-
			Datum	Name	UO 9.500 ND		
		Bearb.	12.04.06	Doe			
		Gepr.					
		Norm					
C	1RV02 nach 1V08	08.02.11	bau		00381480-30000		
B	Option 580012	26.01.10	bau				
A	1RV02	24.04.09	Ke				
Zust.	Änderung	Datum	Name	EDV Nr.	00381480-30000B		Blatt

<b>UO 9.500 ND</b> Code-No. 00381480		<b>Component List</b>	
<b>P+I-No.</b>	<b>Code-No.</b>	<b>Description</b>	
1F01	00 300 021 00 335 067	filter housing FMC3-3S flange DN 50 filter cartridge 30", 5 µm, 3 piece	
1FI01	00 580 044	flowmeter 500-5000 l/h	
1FI02	00 580 047	flowmeter 1-10 m³/h	
1FI03	00 580 043	flowmeter 400-4000 l/h	
1P01	00 390 349	pump CR 15-12, 3x400V/50Hz, 11,0KW	
1Pr01	00 630 006	pressure gauge Ms, NG63, 1/4"h, 0-10 bar	
1Pr02	00 630 006	pressure gauge Ms, NG63, 1/4"h, 0-10 bar	
1Pr03	00 600 012	pressure switch FF4-8, 3/8"	
1Pr04	00 630 008	pressure gauge Ms, NG63, 1/4"h, 0-40 bar	
1Pr05	00 630 209	pressure gauge Ms, NG63, 1/4"h, 0-25 bar	
1Pr06	00 630 209	pressure gauge Ms, NG63, 1/4"h, 0-25 bar	
1Q02	00 100 011	conductivity measuring cell	
1RV01	00 580 012	check valve PVC, DN25, PN16	
1V01	00 405 111	diaphragm valve DN50, pilote controlled, NC	
1V04	00 415 039	ball valve VA, DN40	
1V05	00 415 004	regulating valve- concentrate recirculation, ball valve VA, 3/4"	
1V06	00 415 056	concentrate regulating valve, needle valve VA, 1" IG	
1V07	00 410 084	sample	
1V08	00 405 050	sample	
1VV01	00 405 039	solenoid pilot valve, type 324, G¼", 230V/50Hz	
1X01	00 400 051	vessel GFK, 8040-4, 25 bar	
	00 400 050	vessel GFK, 8040-3, 25 bar	
	00 395 151	low pressure element 8040 ND	
	00 545 401 00 545 376	electric control with micro processor controller RO1000	
option 00382122 cleaning set:			
1V10	00 415 006	cleaning connection, ball valve VA, 1 1/4" IG	
1V11	00 405 325	3 way-ball valve DN40	
1V12	00 405 324	3 way-ball valve DN32	
option 00382373 permeate recirculation:			
1RV02.X	00 580 012	check valve PVC, DN25, PN16	
1RV03	00 580 014	check valve PVC, DN40, PN16	
1V02	00 405 088	diaphragm valve DN40, pilote controlled, NC	
1VV02	00 405 039	solenoid pilot valve Typ 324, G¼", 230V/50Hz	
option 00382374 concentrate rinse valve:			
1V03	00 410 126	solenoid valve Ms, 1", 230V/50Hz	
further optionen:			
1RV02.X	00 580 012	check valve PVC, DN25, PN16	
1X02	00 370 070	hardness monitor Limitron 1 1/2"	
1X03	00 382 284	colloid index measuring device	
	00 541 497	conductivity range permeate 0,5-50 µs/cm	
	00 541 498	conductivity range permeate 20-2.000 µs/cm	
	00 541 499	conductivity range permeate 100-10.000 µs/cm	

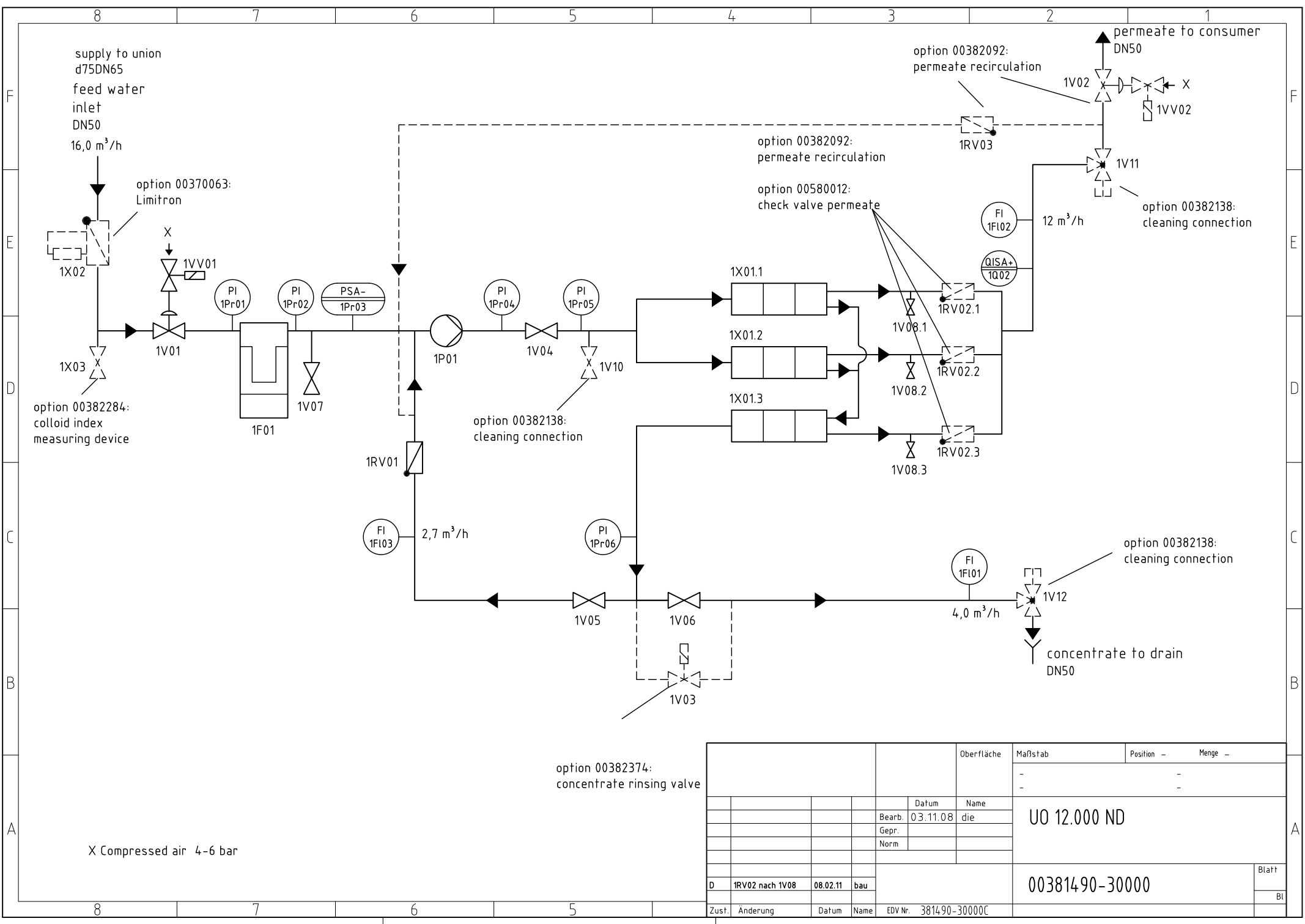

X Compressed air 4-6 bar

option 00382374:  
concentrate rinsing valve

		Oberfläche	Maßstab	Position	Menge
		Datum	Name		
		Bearb.	03.11.08	die	
		Gepr.			
		Norm			
D	1RV02 nach 1V08	08.02.11	bau	Blatt	
Zust.	Änderung	Datum	Name	EDV Nr.	381490-30000C
				Bl	

UO 12.000 ND

00381490-30000

<b>UO 12.000 ND</b> Code-No. 00381490		<b>Component List</b>	
<b>P+I-No.</b>	<b>Code-No.</b>	<b>Description</b>	
1F01	00 300 024 00 335 017	filter housing FMC6-2S flange DN 50 filter cartridge 20", 5 µm, 6 piece	
1FI01	00 580 047	flowmeter 1000-10000 l/h	
1FI02	00 580 048	flowmeter 2-20 m³/h	
1FI03	00 580 043	flowmeter 400-4000 l/h	
1P01	00 390 349	pump CR 15-12, 3x400V/50Hz, 11KW	
1Pr01	00 630 006	pressure gauge Ms, NG63, 1/4"h, 0-10 bar	
1Pr02	00 630 006	pressure gauge Ms, NG63, 1/4"h, 0-10 bar	
1Pr03	00 600 012	pressure switch FF4-8, 3/8"	
1Pr04	00 630 008	pressure gauge Ms, NG63, 1/4"h, 0-40 bar	
1Pr05	00 630 209	pressure gauge Ms, NG63, 1/4"h, 0-25 bar	
1Pr06	00 630 209	pressure gauge Ms, NG63, 1/4"h, 0-25 bar	
1Q02	00 100 011	conductivity measuring cell	
1RV01	00 580 012	check valve PVC, DN25, PN16	
1V01	00 405 111	diaphragm valve DN50, pilote controlled, NC	
1V04	00 415 065	ball valve VA, DN50	
1V05	00 415 004	regulating valve- concentrate recirculation, ball valve VA, 3/4"	
1V06	00 415 181	concentrate regulating valve, needle valve VA, 1½" IG	
1V07	00 410 084	sample	
1V08	00 405 050	sample	
1VV01	00 405 039	solenoid pilot valve type 324, G¼", 230V/50Hz	
1X01	00 400 050 00 395 151	vessel GFK, 8040-3, 25 bar low pressure element	
	00 545 401 00 545 376	electric control with micro processor controller RO1000	
option 00382138 cleaning set:			
1V10	00 415 007	cleaning connection, ball valve VA, 1 1/2" IG	
1V11	00 405 326	3 way-ball valve DN50	
1V12	00 405 326	3 way-ball valve DN50	
option 00382092 permeate recirculation:			
1RV02.X	00 580 015	check valve PVC, DN32, PN16	
1RV03	00 580 015	check valve PVC, DN50, PN16	
1V02	00 405 111	diaphragm valve DN50, pilote controlled, NC	
1VV02	00 405 039	solenoid pilot valve Typ 324, G¼", 230V/50Hz	
option 00382374 concentrate rinse valve:			
1V03	00 410 126	solenoid valve Ms, 1", 230V/50Hz	
further optionen:			
1RV02.X	00 580 012	check valvePVC, DN32, PN16	
1X02	00 370 063	hardness monitor Limitron 2"	
1X03	00 382 284	colloid index measuring device	
	00 541 497	conductivity range permeate 0,5-50 µs/cm	
	00 541 498	conductivity range permeate 20-2.000 µs/cm	
	00 541 499	conductivity range permeate 100-10.000 µs/cm	

Kopieren oder Weitergabe nur mit unserer schriftlichen Genehmigung gestattet

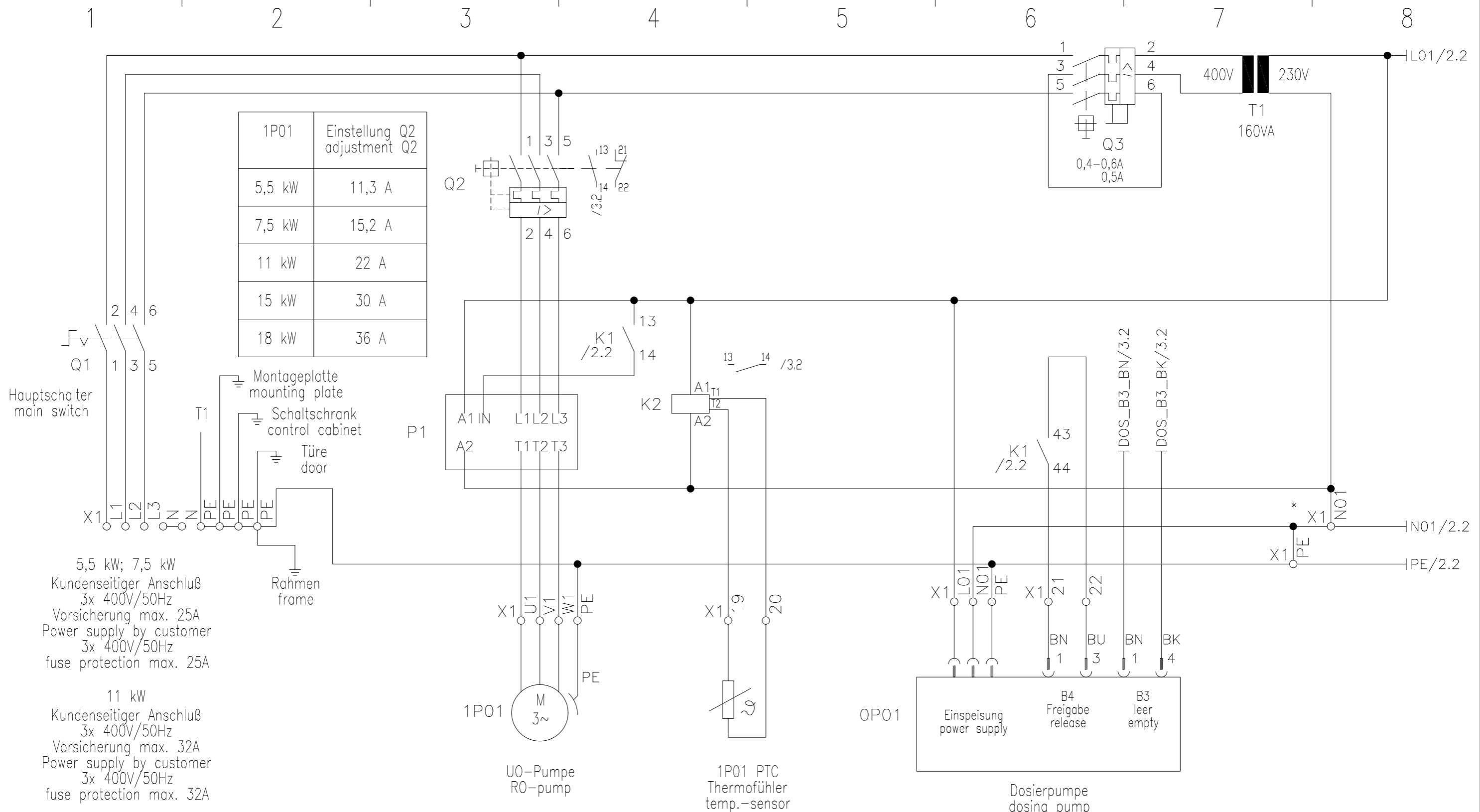

5,5 kW; 7,5 kW  
Kundenseitiger Anschluß  
3x 400V/50Hz  
Vorsicherung max. 25A  
Power supply by customer  
3x 400V/50Hz  
fuse protection max. 25A

11 kW  
Kundenseitiger Anschluß  
3x 400V/50Hz  
Vorsicherung max. 32A  
Power supply by customer  
3x 400V/50Hz  
fuse protection max. 32A

15 kW; 18,5 kW  
Kundenseitiger Anschluß  
3x 400V/50Hz  
Vorsicherung max. 40A  
Power supply by customer  
3x 400V/50Hz  
fuse protection max. 40A

Achtung!  
Klemmbrett auch bei Stillstand unter Spannung  
Danger!  
Terminal block also in case of shut-down under voltage!

Vor Reparaturarbeiten Hauptschalter ausschalten!  
Before service work switch-off main switch!

\*Bei Entfernen der Brücke ist ein  
Isolationswächter nach VDE 0100 einzubauen  
\*Install isolation monitor according to VDE 0100,  
if bridge is removed

Revision	Datum	Name	Datum	Name
a			gez. 24.03.09	Jm
b				
c			gepr. 06.04.09	Tie
d				

Hauptstromkreis  
main supply circuit

Projektbez. R01000-II / 5,5 - 18,5 kW		=
Auftragsnr.	Zeichnungsnr. 545399-01000	+

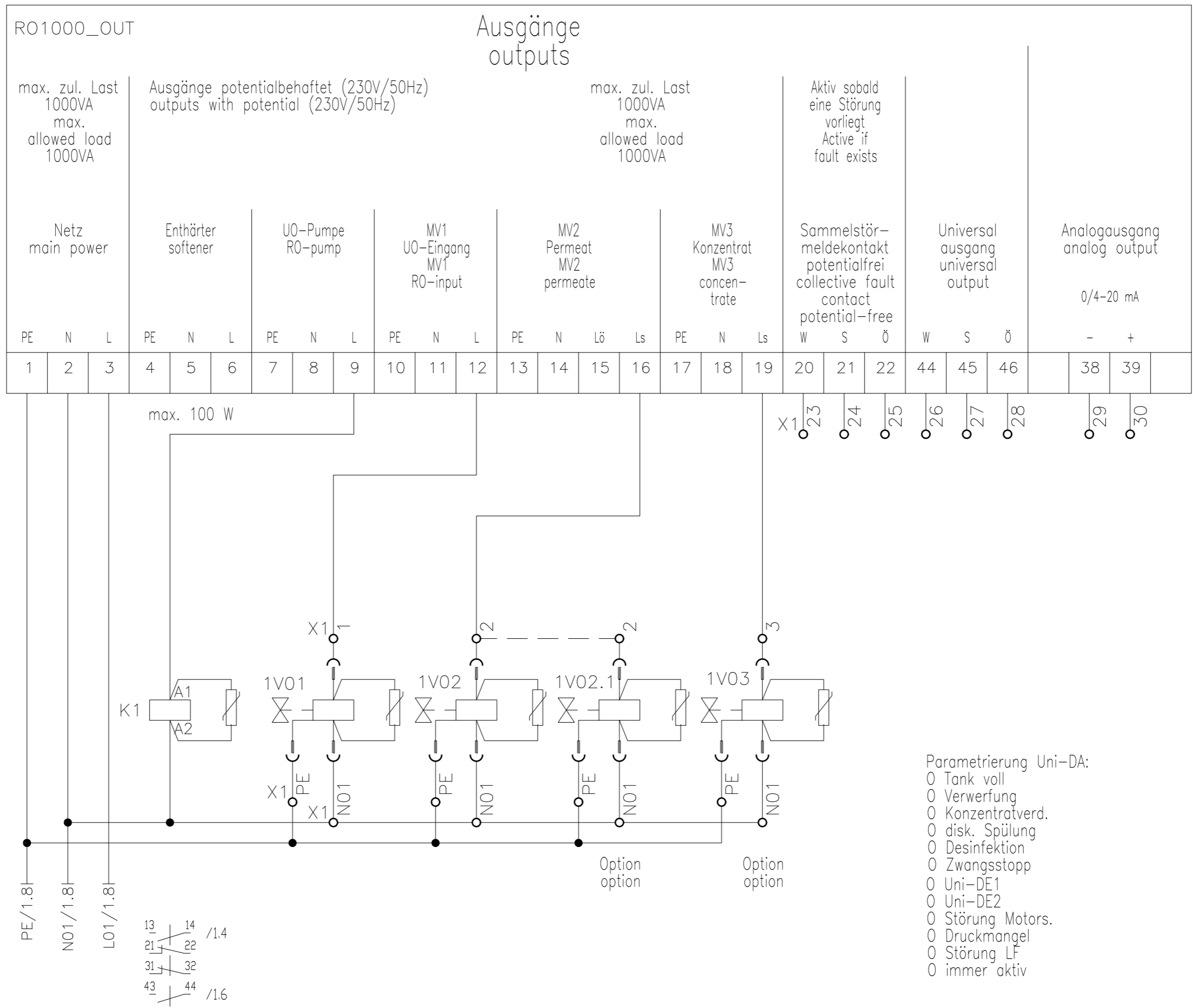

- Parametrierung Uni-DA:
- Tank voll
  - Verwerfung
  - Konzentratverd.
  - disk. Spülung
  - Desinfektion
  - Zwangsstopp
  - Uni-DE1
  - Uni-DE2
  - Störung Motors.
  - Druckmangel
  - Störung LF
  - immer aktiv

Revision	Datum	Name	Datum	Name
a			gez. 24.03.09	Jm
b				
c			gepr. 06.04.09	Tie
d				

Anschlußbelegung RO1000  
Terminals RO1000

Projektbez. RO1000-II / 5,5 - 18,5 KW		=
Auftragsnr.	Zeichnungsnr. 545399-01000	+

1 2 3 4 5 6 7 8

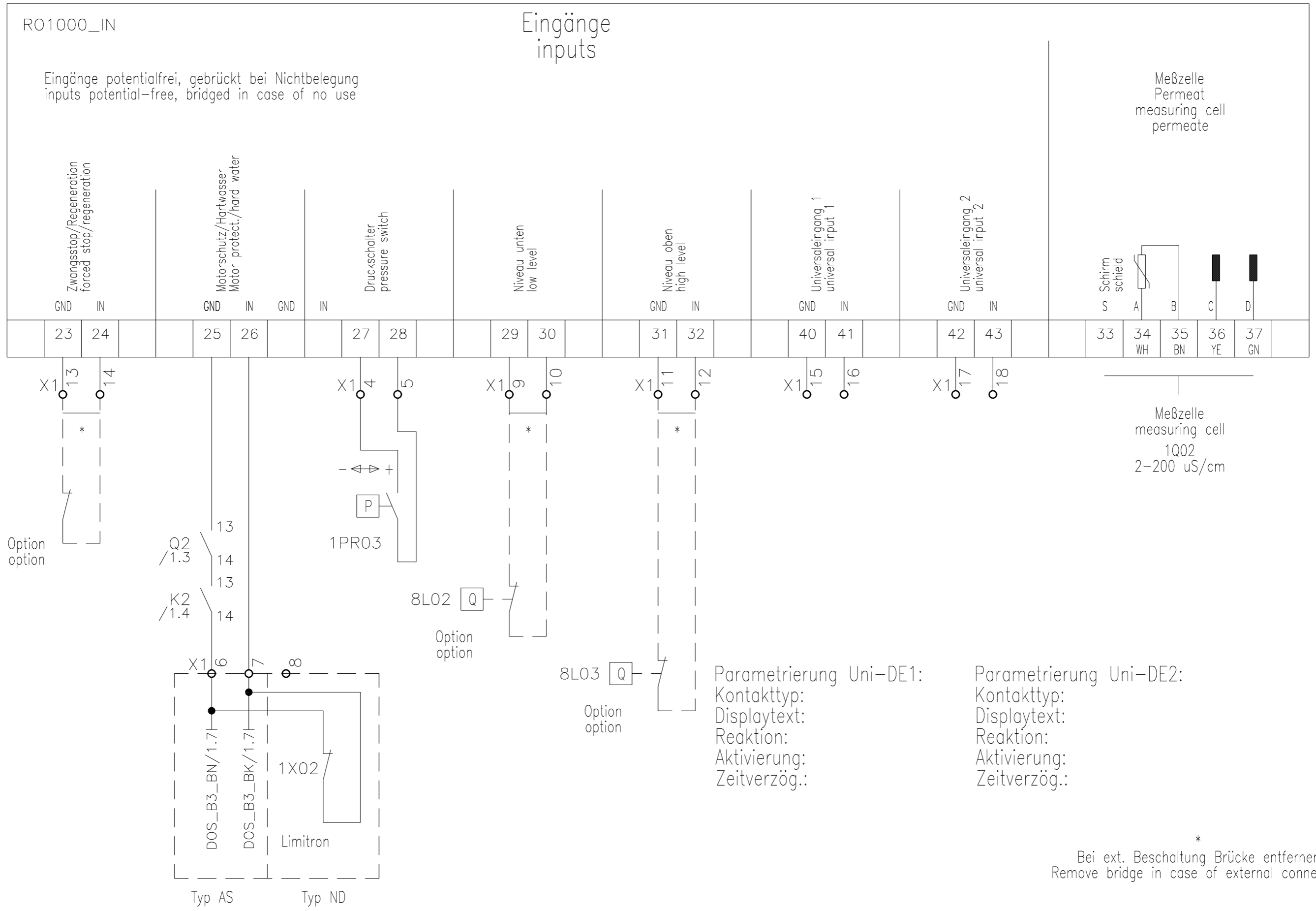

Revision	Datum	Name	Datum	Name
a			gez. 24.03.09	Jm
b				
c			gepr. 06.04.09	Tie
d				

Anschlußbelegung RO1000  
Terminals RO1000

Projektbez. RO1000-II / 5,5 - 18,5 KW	=	
Auftragsnr.	Zeichnungsnr. 545399-01000	Blatt 3 6 Bl.



Kopieren oder Weitergabe nur mit unserer schriftlichen Genehmigung gestattet

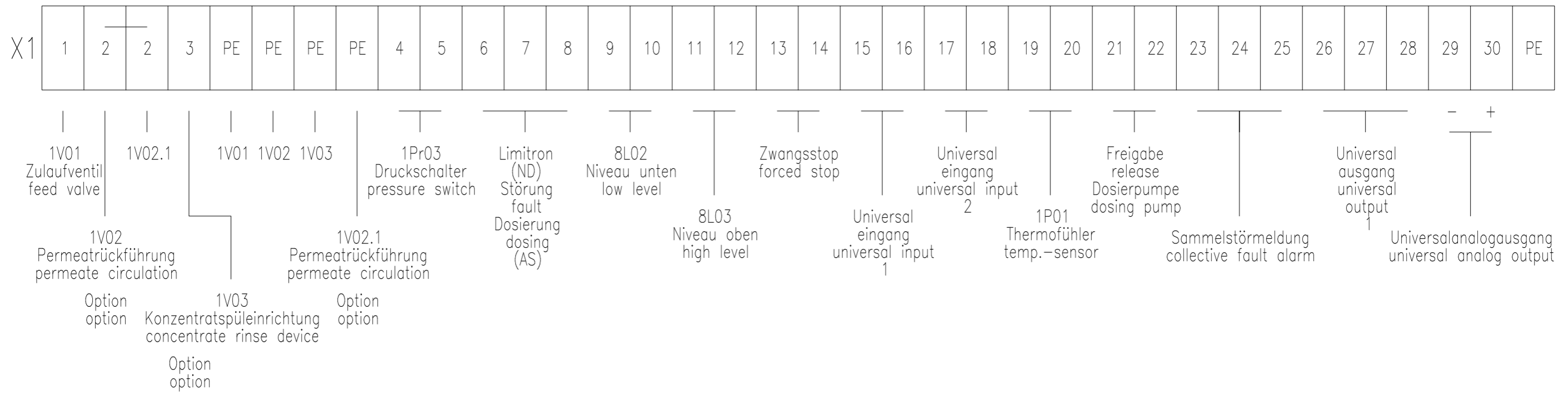
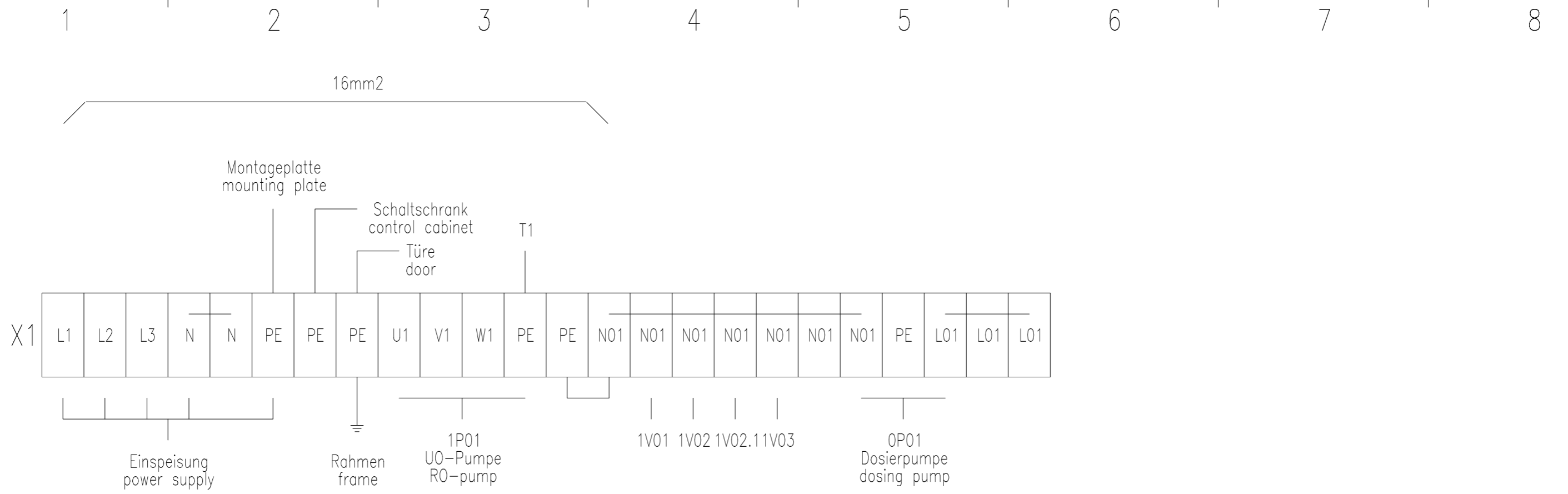

Revision	Datum	Name	Datum	Name
a			gez. 24.03.09	Jm
b				
c			gepr. 06.04.09	Tie
d				

X1	Projektbez. RO1000-II / 5,5 - 18,5 KW	Blatt 4
	Auftragsnr.	

Kopieren oder Weitergabe nur mit unserer schriftlichen Genehmigung gestattet

1

2

3

4

5

6

7

8

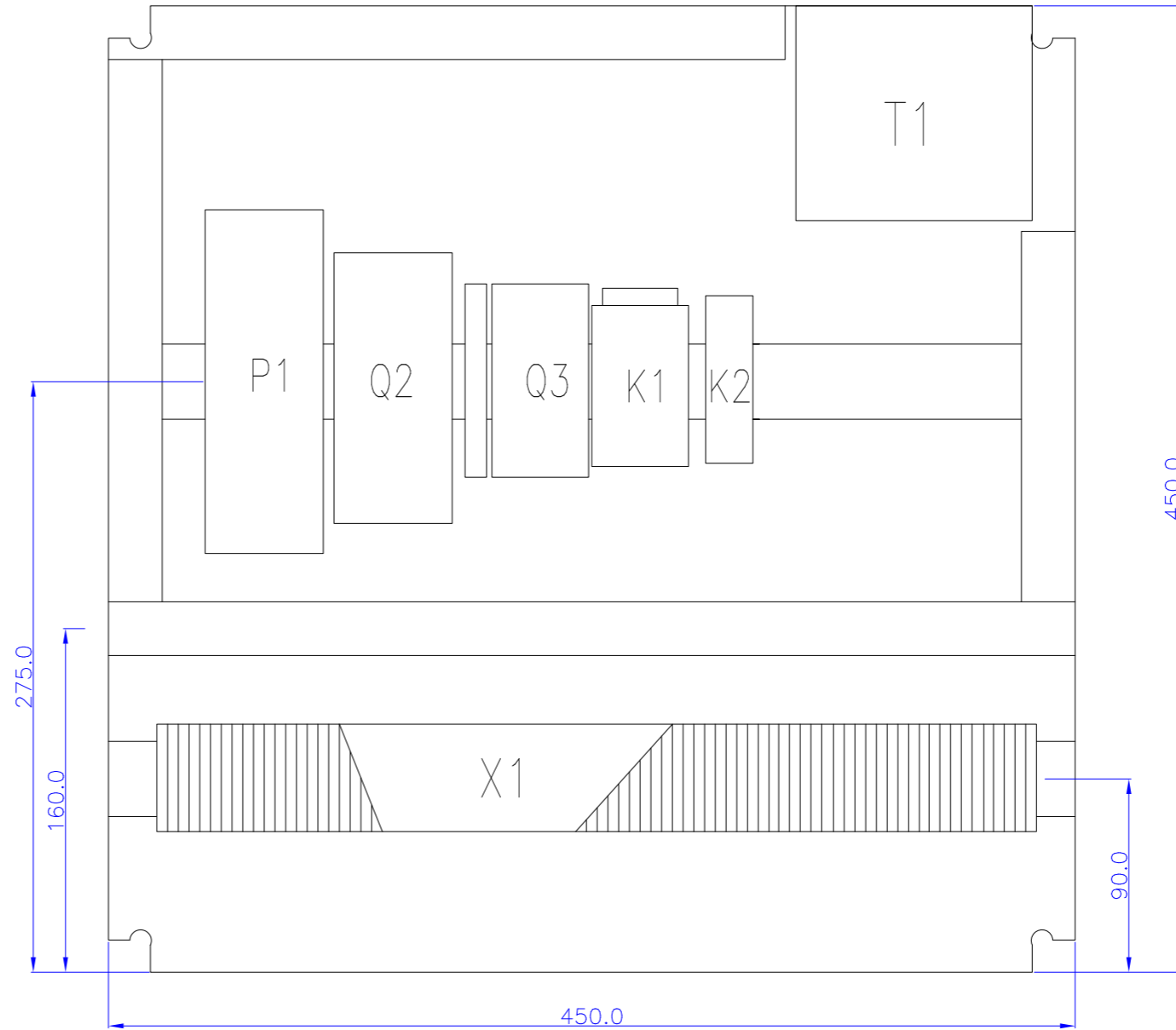

Sicherung fuse:      Aderndimensionierung wire dimensions:

16A	1,5 mm <sup>2</sup>
20A	2,5 mm <sup>2</sup>
25A	4 mm <sup>2</sup>
32A	6 mm <sup>2</sup>
40A	10 mm <sup>2</sup>
50A	10 mm <sup>2</sup>
63A	16 mm <sup>2</sup>
80A	25 mm <sup>2</sup>
100A	35 mm <sup>2</sup>

Aderfarben / wire colors:

Versorgungsspannung / supply voltage: BK  
 Steuerspannung / control voltage: RD (230VAC), BU (24VDC)  
 Fremdspannung / external voltage: OG  
 Nullleiter / neutral conductor: BU  
 Schutzleiter / protective conductor: GNYE

Revision	Datum	Name	Datum	Name
a			gez. 24.03.09	Jm
b				
c			gepr. 06.04.09	Tie
d				

Schaltschrank  
control cabinet

Projektbez. R01000-II / 5,5 - 18,5 KW	=
Auftragsnr.	+
Zeichnungsnr. 545399-01000	

Blatt	5
6	Bl.

Kopieren oder Weitergabe nur mit unserer schriftlichen Genehmigung gestattet

1                      2                      3                      4                      5                      6                      7                      8

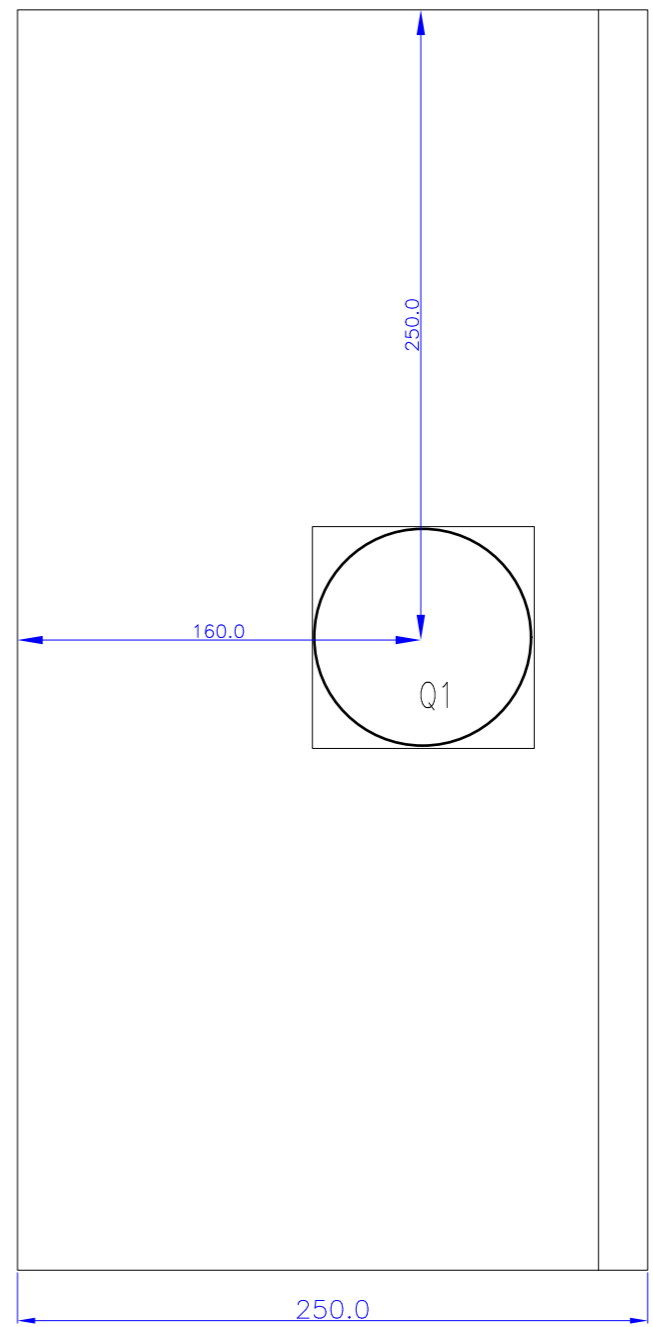
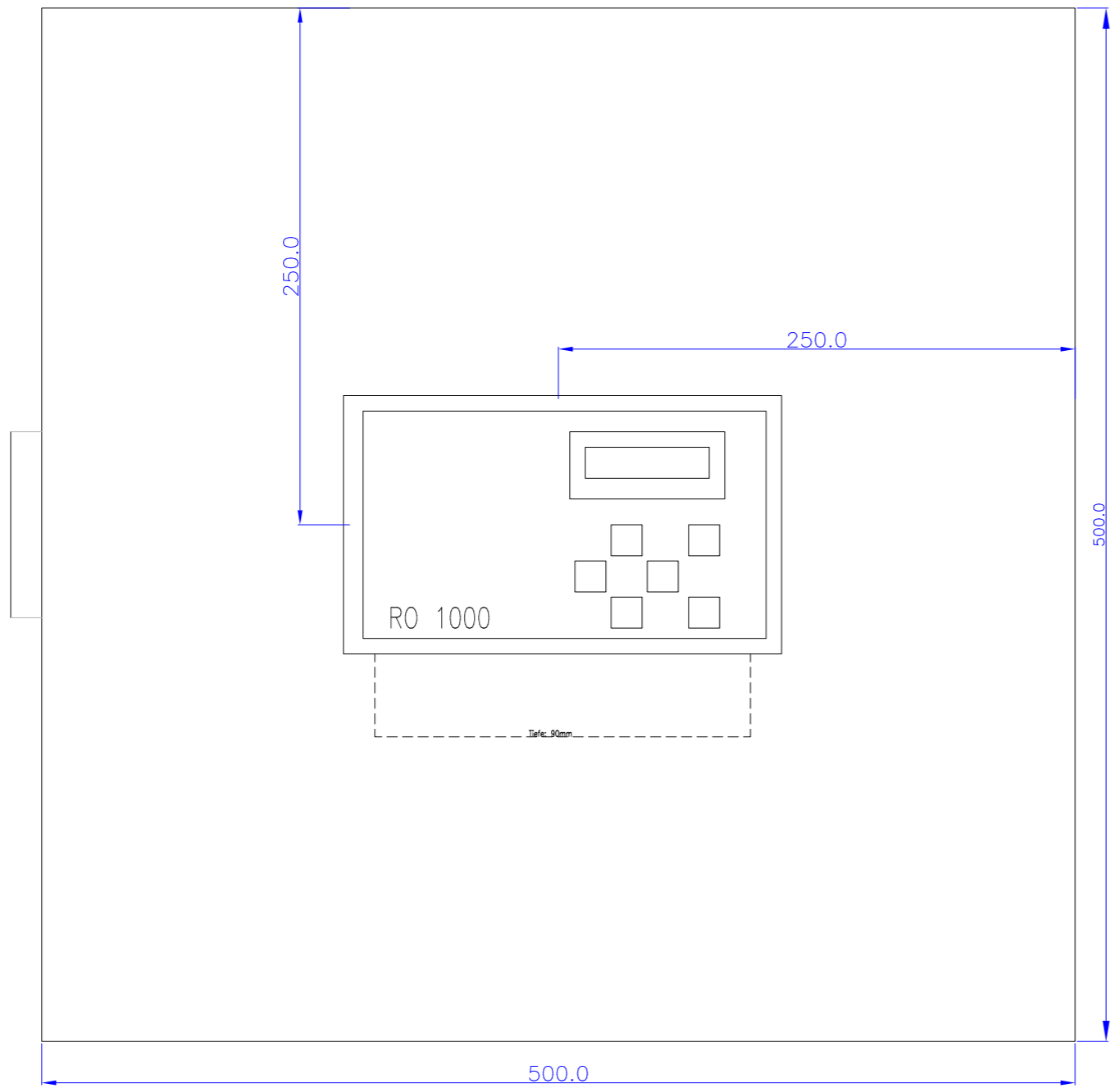

Revision	Datum	Name		Datum	Name
a			gez.	24.03.09	Jm
b					
c			gepr.	06.04.09	Tie
d					

Schaltschrank  
control cabinet

Projektbez.  
RO1000-II / 5,5 - 18,5 KW  
Auftragsnr.                      Zeichnungsnr.  
545399-01000

=	
+	
Blatt	6
6	Bl.

# Operating manual RO1000

Software V02.28

<b>Last update</b>	<b>Date</b>	<b>Author</b>	<b>Remarks / Software Version</b>
Preliminary version	28/04/09	Jm	
Preliminary version II	30/04/09	Tie	
1	26.06.09	Tie	Additional Parameters 9.22, 9.23, 9.24
2	03.08.09	Tie	diverse modifications / additions
3	20.04.10	Tie	diverse modifications parameters
4			
5			

# Contents

- 1 Introduction ..... 4
  - 1.1 Description ..... 4
  - 1.2 Notational conventions ..... 4
  - 1.3 Intended use ..... 4
- 2 Identification ..... 5
  - 2.1 Designation of the device ..... 5
  - 2.2 Scope of supply ..... 5
  - 2.3 Accessories ..... 5
- 3 Assembly ..... 6
  - 3.1 Mounting conditions ..... 6
  - 3.2 Dimensions ..... 6
- 4 Electrical connection ..... 7
  - 4.1 Wiring at a glance ..... 7
  - 4.2 Terminal layout ..... 7
    - 4.2.1 Cable specifications ..... 8
  - 4.3 Wiring diagrams ..... 8
- 5 Functional description ..... 9
  - 5.1 Operating statuses ..... 9
  - 5.2 Disinfection ..... 9
  - 5.3 Diagnosis ..... 9
  - 5.4 Operating phases ..... 10
    - 5.4.1 Operation flow chart ..... 10
    - 5.4.2 Rejection ..... 11
    - 5.4.3 Production ..... 11
    - 5.4.4 Tank full / standby ..... 11
    - 5.4.5 Discontinuous rinse ..... 11
    - 5.4.6 Concentrate displacement / rinse ..... 12
- 6 Operation ..... 13
  - 6.1 Operation at a glance ..... 13
  - 6.2 Display and control elements ..... 13
  - 6.3 Entering text and figures ..... 15
    - 6.3.1 Menu items ..... 15
    - 6.3.2 Data editing ..... 15
    - 6.3.3 Confirmations ..... 16
  - 6.4 Passwords ..... 17
- 7 Parameters and settings ..... 18
- 8 Operation of the installation by personnel ..... 22
  - 8.1 Changing the operating mode ..... 22
  - 8.2 Parameterisation of the digital output ..... 23
  - 8.3 Parameterisation of digital inputs ..... 25
  - 8.4 Parameterisation of standard inputs ..... 27
  - 8.5 Setting of conductivity and temperature limits ..... 28
  - 8.6 Setting the times ..... 29
  - 8.7 Setting the selection parameters ..... 30
  - 8.8 Selection of fault options ..... 31
  - 8.9 Carrying out a reset ..... 32
  - 8.10 Measuring and calibrating ..... 33
  - 8.11 Diagnosis ..... 34

9	Malfunctions and their elimination .....	36
9.1	Indication and acknowledgement .....	36
9.2	Description of and search for malfunctions .....	36
9.2.1	Lack of pressure .....	36
9.2.2	Motor failure / Hard water .....	37
9.2.3	Conductivity warning .....	37
9.2.4	Conductivity exceeded .....	37
9.2.5	Rejection time exceeded.....	37
9.2.6	Temperature fault .....	38
9.2.7	External Stop .....	38
9.2.8	External stop (Tank full) .....	38
9.2.9	External emergency stop .....	38
10	Disposal.....	39
11	Technical Appendices .....	40
11.1	Technical data .....	40
11.2	Overview of the menu .....	41
11.3	Wiring diagram / sample connection .....	42

# 1 Introduction

## 1.1 Description

The RO1000 control is used for the fully automatic control of reverse osmosis installations.

## 1.2 Notational conventions

The following abbreviations are used throughout this manual:

<b>Lim</b>	Limit
<b>CD</b>	Conductivity
<b>T</b>	Temperature
<b>t</b>	Time/Duration
<b>high</b>	Output or input actuated
<b>low</b>	Output or input not actuated

The following notations are used throughout this manual:

Type:	Font:	Example:
Keys:	capitals + bold	<b>LEFT, UP, DOWN</b>
LEDs:	capitals + bold	<b>PRODUCTION, MALFUNCTION/FAULT</b>
Inputs/outputs, inlets/outlets:	capitals + bold	<b>INLET VALVE</b>
Operating parameters:	italics	<i>cond.raww., water volume</i>
Operating status:	capitals + underlined	<u>TURNED ON, TURNED OFF</u>
Operating modes:	capitals + underlined	<u>AUTOMATIC, MANUAL</u>
Malfunctions:	capitals + underlined	<u>SENSOR DEFECT</u>

## 1.3 Intended use

This controller is intended to control reverse osmosis installations in non explosion-prone areas.

- The device can be mounted on top of an installation or mounted into an installation. Another mounting type is not permitted.
- The manufacturer is not liable for damages resulting from improper or unintended use. Improper or unintended use may turn the controller into a hazardous device.

## 2 Identification

### 2.1 Designation of the device

Compare the nameplate at the right side or at the backside of the device to the bill of materials and the following figure:

Casing for top mounting, item no. 545377:

Schutzart: IP65 00545377-NE21-xxxx  Elektrischer Anschluss V/Hz 230/50-60 Anschlussleistung 15W
---

Built-in casing, item no. 545376:

Schutzart: IP54 00545376-NE21-xxxx  Elektrischer Anschluss V/Hz 230/50-60 Anschlussleistung 15W
---

Built-in casing 24V/DC, item no. 545378:

Schutzart: IP54 00545378-NE21-xxxx  Elektrischer Anschluss 24VDC Anschlussleistung 20W
--

### 2.2 Scope of supply

- Device with terminal block
- Terminal block plan (inside the terminal block cover of the top mounting casing)
- Bill of materials

### 2.3 Accessories

We offer the following optional accessories for the controller:

- Item no. 100018: measurement cell 1.5 inch; 0.5-50  $\mu\text{S}/\text{cm}$ ; cell constant 0.045.
- Item no. 100011: measurement cell 1.5 inch; 2-200  $\mu\text{S}/\text{cm}$ ; cell constant 0.125.
- Item no. 100026: measurement cell 1.5 inch; 20-2000  $\mu\text{S}/\text{cm}$ ; cell constant 0.23.
- Item no. 100027: measurement cell 1.5 inch; 100-10,000  $\mu\text{S}/\text{cm}$ ; cell constant 0.58.
- Item no. 383100: Standard front foil 4 languages



## 3 Assembly

### 3.1 Mounting conditions

Working temperature range: 0 to 40 °C (32 to 104 °F), humidity, non-condensing.

#### Caution!

- Please provide sufficient cooling of the installation in order to avoid heat accumulation.
- Make sure there is sufficient distance to strong magnetic fields.
- Environment in compliance with protection category IP65 (top mount housing) or IP54 (built-in housing).

### 3.2 Dimensions

	<b>Length</b>	<b>Width</b>	<b>Depth</b>
<b>Top mount controller</b>	213 mm	185 mm	104 mm
<b>Built-in controller</b>	210 mm	125 mm	90 mm

## 4 Electrical connection

### 4.1 Wiring at a glance

#### Warning!

Note that the entire electric connection may only be carried out while the device is disconnected from the mains.

#### Caution!

- The protective earth connection must be carried out before any other connection. Danger may occur if the PE wire is interrupted.
- Before performing the start-up, make sure that the supply voltage corresponds to the value indicated on the nameplate (right side or back side of casing).
- Combining low safety voltage and voltage presenting a risk of electrocution at the relays is not permitted.
- For the mains line of the 230 VAC versions, over current protection (nominal current  $\leq 16$  A) is required.

#### Note!

Please also observe the terminals plan inside the terminal block cover.

### 4.2 Terminal layout

Terminal	Function	Type	Comment
<b>Type 230 VAC:</b>			
1	Power in Supply voltage 230VAC	PE	Internal fuse: 6.3 AT
2		N	
3		L	
4	Power out Supply voltage 230 VAC	PE	Supply voltage for water softener, max. 100W
5		N	
6		L	
7	P1 RO pump	PE	Max. 1000 VA
8		N	
9		LNO	
10	MV1 RO input	PE	Max. 100 VA
11		N	
12		LNO	
13	MV2 Permeate	PE	Max. 100 VA
14		N	
15		LNC	
16		LNO	
17	MV3 Concentrate	PE	Max. 100 VA

Terminal	Function	Type	Comment
<b>Type 24 VDC:</b>			
1	Power in Supply voltage 24VDC	PE	Internal fuse: 6.3 AT
2		-	
3		+	
4	Power out Supply voltage 24VDC	PE	
5		-	
6		+	
7	P1 RO pump	PE	Max. 50 W
8		-	
9		+ NO	
10	MV1 RO input	PE	Max. 50 W
11		+	
12		+ NO	
13	MV2 Permeate	PE	Max. 50 W
14		-	
15		+ NC	
16		+ NO	
17	MV3 Concentrate	PE	Max. 50 W
18		-	
19		+ NO	

Terminal	Function	Type	Comment
20	Fault Centralised fault indication contact	COM	Voltage-free contact 230 VAC/4A 24 VDC/1A
21		No	
22		NC	
44	Uni-DO Universal output	COM	Voltage-free contact 230 VAC/4A 24 VDC/1A
45		NO	
46		NC	
23	Stop External Stop	GND	For voltage-free, external contact
24			
25	MOT Motor protection/hard water	GND	For voltage-free, external contact
26			
27	PS Pressure Switch	GND	For voltage-free, external contact
28			
29	LL Low level	GND	For voltage-free, external contact
30			
31	HL High level	GND	For voltage-free, external contact
32			
40	Uni 1 Universal input 1	GND	For voltage-free, external contact
41			
42	UNI 2 Universal input 2	GND	For voltage-free, external contact
43			
33	Temp. + Cond. Permeate measurement cell	Shield	
34		Temp. A	
35		Temp. B	
36		Cond. A	
37		Cond. B	
38	I- OUT Analogue output	GND	
39			

## 4.2.1 Cable specifications

Terminals	Cable min.	Cable max.	Cable type
Supply voltage	3x1.0 mm <sup>2</sup>	3x1.5 mm <sup>2</sup>	NYM-J/Ölflex 110

## 4.3 Wiring diagrams

In the appendix you will find examples of the wiring configuration.

## 5 Functional description

### 5.1 Operating statuses

The RO1000 can be set to the following operating statuses:

- STOP
- PRODUCTION
- DISINFECTION
- DIAGNOSIS

### 5.2 Disinfection

The installation runs **without any safety devices** in order to allow continuous DISINFECTION.

The **VALVES** 1V01 and 1V02 are open; the **PUMP** 1P01 is running.

After DISINFECTION, it must be ensured that the installation is free from any disinfectant.

#### **Caution!**

When in this operating status, the installation is running without any safety devices.

### 5.3 Diagnosis

The DIAGNOSIS can be called up via the menu (parameter 10). In this operating status, all outputs of the controller can be manipulated via the membrane keyboard and the status of the controller inputs can be shown.

#### **Caution!**

The units connected to the controller outputs are triggered without any safety devices if the respective output is actuated in diagnosis mode!

## 5.4 Operating phases

### 5.4.1 Operation flow chart

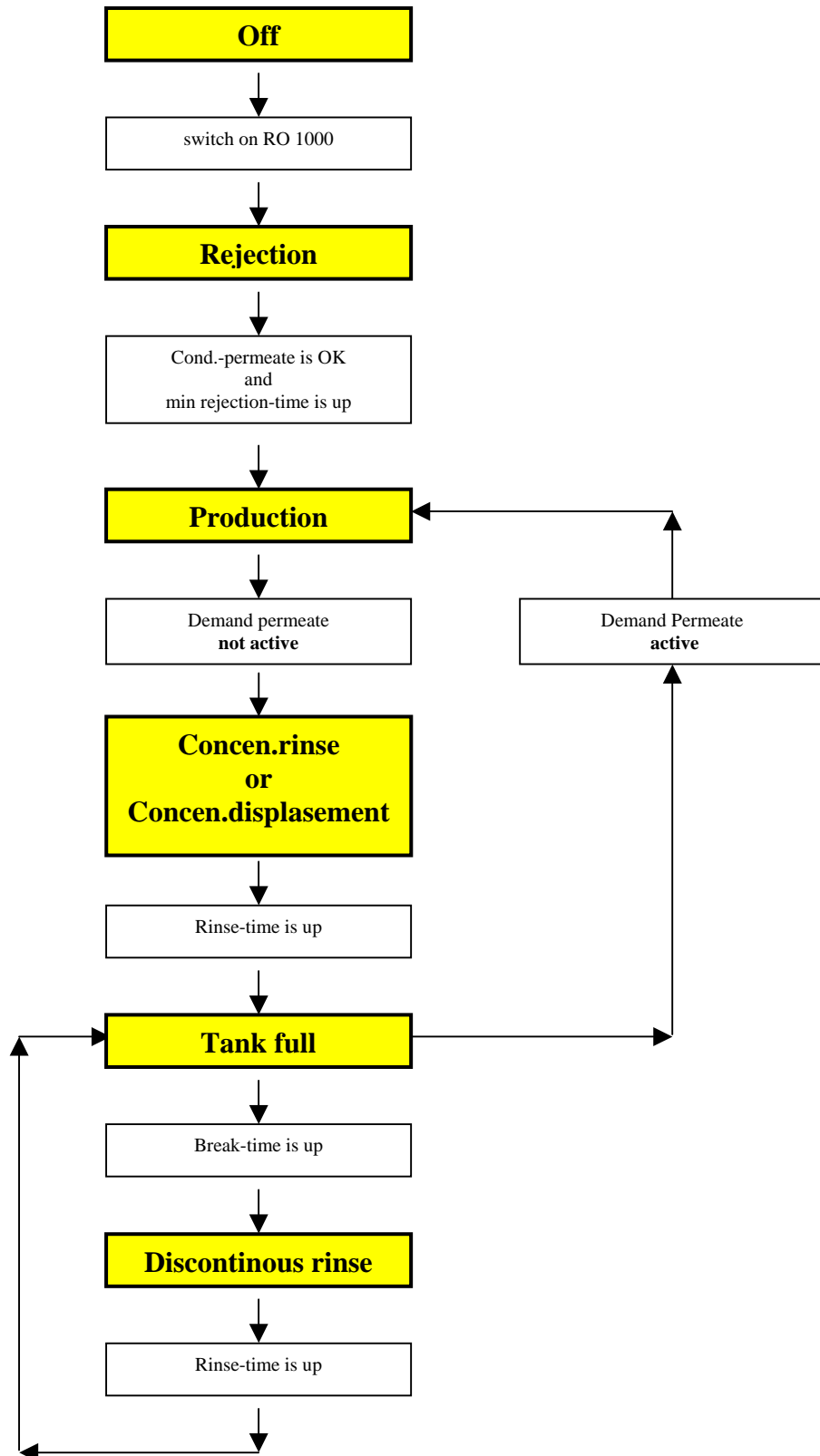

## 5.4.2 Rejection

During the REJECTION phase, the permeate is recycled or sent to the drain, depending on the installation configuration. The permeate is rejected until its conductivity has fallen below the limit (parameter 6.1.1). For REJECTION a minimum duration (parameter 9.9.1) as well as a maximum duration (parameter 9.9.2) have been defined.

During REJECTION, the **VALVE** 1V01 is opened and the **PUMP** 1P01 is running. The **PERMEATE VALVE** 1V02 remains closed.

No permeate is carried towards the consumer.

## 5.4.3 Production

During the PRODUCTION phase, permeate is produced until the Tank Full message is activated. The display indicates the following messages alternately:

- RO1000 – V 02.xx; Production on
- Permeate xx °C; xxx.x µS/cm
- Operating hours; xx h xx min

During this operating phase, the **PUMP** 1P01 runs and the **VALVES** 1V01 and 1V02 are opened. The installation produces permeate.

## 5.4.4 Tank full / standby

During PRODUCTION the permeate tank is filled until the Tank Full message is activated. If the full level is reached, the installation changes to TANK FULL. If further filling is required by the **LEVEL SWITCH**, the installation returns to PRODUCTION.

During this state, the **PUMP** 1P01 runs and the **VALVES** 1V01 and 1V02 are closed. No permeate is produced.

## 5.4.5 Discontinuous rinse

If the installation remains in STANDBY for a certain, settable time (parameter 9.7), DISCONTINUOUS RINSE is carried out for a settable time (parameter 9.8). If the parameter 9.7 is set to zero, the DISCONTINUOUS RINSE is switched off.

During this state, the **PUMP** 1P01 runs, the **VALVE** 1V01 is opened and the **VALVE** 1V02 is either closed (“*Tank without overflow*”) or opened (“*Tank with overflow*”), depending on parameter 9.13.

#### 5.4.6 Concentrate displacement / rinse

If, during PRODUCTION, the upper level input is activated, the installation switches to CONCENTRATE DISPLACEMENT / RINSE for a parameterisable time (parameter 9.8). During this operating phase, the **PUMP** 1P01 runs (only during rinse), the **VALVE** 1V01 is open and the **VALVE** 1V02 is closed; if “*Tank with overflow*” is parameterised, the **VALVE** remains open.

## 6 Operation

### 6.1 Operation at a glance

The controller is easy to understand so that it is almost possible to begin using the unit for many applications without the operating manual.

It shows the setting limits and standard settings for the respective parameters on the screen.

The integrated process visualization displays the activated aggregates (pump 1P01, valves 1V01, 1V02, 1V03, pressure switch 1PR03) on the operators interface. Aggregates which are not activated are displayed as ----. If demanded, the process visualization can be disabled by adjusting parameter 9.24 to "0000".

Below these you will find explanations on the controller for the elements that are not clearly described through text or the selection lists. We reserve the right to make changes that serve technical progress.

### 6.2 Display and control elements

The operator interface consists of a text display (16x2 characters), 6 keys as well as LEDs for **PRODUCTION**, **FAULT**, **DISINFECTION**, **REJECT**, **EXTERNAL STOP** and **TANK FULL**. It also has an acoustic alarm.



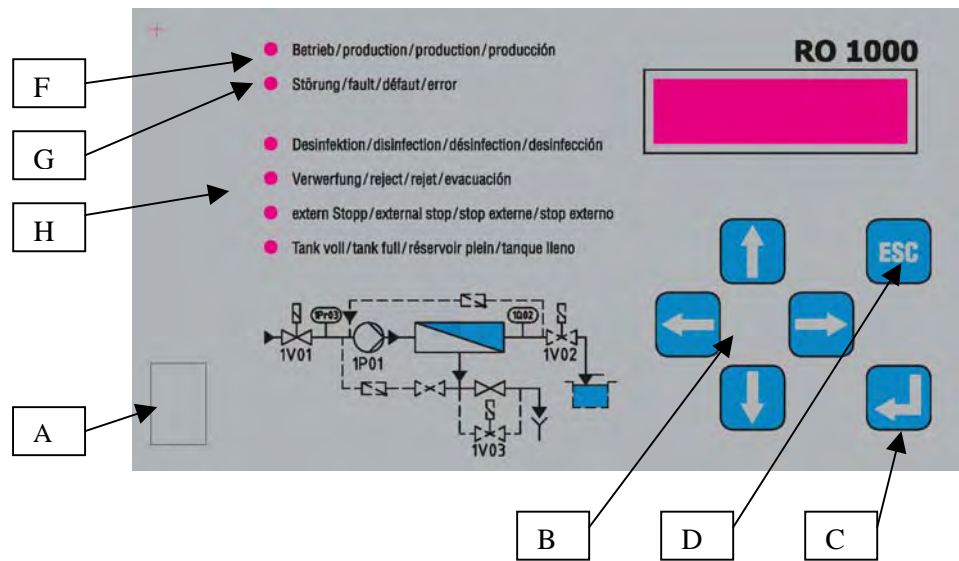

	Designation	Function
A	Mains switch	- Turning on and off the installation → top-mount housing only
B		- Password entry - Menu selection - Selection
C		- Confirm inputs - Call up menu
D		- Exit menu - Fault acknowledgement
E	Display	Display of: - current operating mode - permeate conductivity and temperature - operating hours - current faults
F	LED <b>PRODUCTION</b> (green)	Permanent: → installation running Flashing: Maintenance required
G	LED <b>FAULT</b> (red)	Fault active
H	Operating modes LEDs (yellow)	
	<b>DISINFECTION</b>	Disinfection active
	<b>REJECTION</b>	Permeate rejection active
	<b>EXTERNAL STOP</b>	<b>External Stop</b> input active Permeate production interrupted
	<b>TANK FULL</b>	<b>Upper level</b> input active Permeate production interrupted

## 6.3 Entering text and figures

### 6.3.1 Menu items

The menu consists of several items in a list (arranged one below the other) that can be longer than the number of items displayed on the screen.



A menu item is selected with the arrow ► on the left side of the screen. The arrow is moved with the **UP** and **DOWN** keys to the menu item of your choice. The marked menu item is then selected with the **ENTER** key. If the list of menu items is longer than the part displayed on the screen, the controller scrolls automatically.

Note:

- Most of the menus have a hierarchical structure, i.e., upon selection of a menu item, an additional submenu opens.
- You can usually leave a menu by pressing the **ESC** key (return to standard level).

### 6.3.2 Data editing

Editing is generally carried out via a special screen in which the parameters are displayed. Any editing process may be aborted without saving the changed value by pressing **ESC**. When editing parameters, the following data types are to be differentiated:



## Numerical data

Numerical editing is carried out to adjust the operating parameters and to set the reference parameters. Numerical editing is done in the same way a decade switch is used.

The digit to be changed is selected with the cursor (a block in the display) and set to the desired value by pressing the **UP** / **DOWN** keys as often as necessary. By means of the **LEFT** / **RIGHT** keys, the cursor can be moved to the other digits so that these can be modified as well. The value indicated is stored using the **ENTER** key.



## Selection data

In some cases an option can be selected (operating statuses, operating modes). Upon selection of the option, the operator can scroll through all further options with the **UP** / **DOWN** keys. The displayed selection is confirmed with the **ENTER** key.

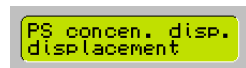

## Alphanumerical data

The message texts can be edited alphanumerically. The procedure is identical to that of numerical editing, but it is possible to select numbers and characters with the **UP** and **DOWN** keys.



### 6.3.3 Confirmations

For safety reasons and to avoid erroneous settings, some functions require confirmation.



By confirming with **Enter** the selected function is carried out. By pressing **Esc** the function is aborted.

## 6.4 Passwords

The different menus, functions and settings are accessible via 4-digit, numerical passwords. The following two hierarchical access levels are differentiated.

Access level	Name of level	Initial password	Password necessary for...
1	User level	"1234"	user and parameter levels

If a password is asked for, it must be entered and confirmed with the **Enter** key.

If a wrong password is entered or if the password entry is aborted with **Esc**, the access is denied.

### Note:

- It is possible, when a password is asked for, to enter the password of a higher level. Since the access to the superior level is granted until the menu is exited, passwords will not have to be re-entered if additional functions are carried out.

## 7 Parameters and settings

Parameter	Function	Format/ Unit	Selection/ Limit	Default setting	Individual setting
<b>0 Logging</b>			- On - Off		
<b>1 Fault Reset</b>					
<b>2 Operating mode</b>			- Stop - Operation - Rinse - Disinfection		
<b>3 Cond.-permeate</b>					
<b>4 Temp.-permeate</b>					
<b>5 Operating hours</b>					
For settings after this menu a password is requested User-password: 1 2 3 4 (not changeable)					
<b>6 Limits</b>					
6.1 Cond.-limits					
6.1.1 LIM	Fault Conductivity		Meas.1: 0,5-50 µS/cm Meas.2: 2-200 µS/cm Meas.3: 20-2000 µS/cm Meas.4: 100-10000 µS/cm	1: 20,0 2: 50,0 3: 500 4: 3000	
6.1.2 WAR	Warning Conductivity		Meas.1: 0,5-50 µS/cm Meas.2: 2-200 µS/cm Meas.3: 20-2000 µS/cm Meas.4: 100-10000 µS/cm	1: 15,0 2: 40,0 3: 400 4: 2000	
6.2 T-limits					
6.2.1 T_min	Minimum Temperature	xx.x °C	0.0 - 99,9	5.0	
6.2.2 T_max	Maximum Temperature	xx.x °C	0.0 - 99,9	40.0	
<b>7 Alarm options</b>					
7.1 conductivity			- stop - do not stop	do not stop	
7.2 temperature			- stop - do not stop	do not stop	
<b>8 Calibration</b>					
8.1 Analogue input					
Temp. permeate					
Cali low		°C	0.0 - 99,9		
Cali high		°C	0.0 - 99,9		
Default					
Cond. permeate					
Cali low		µS/cm	0 - 9999		
Cali high		µS/cm	0 - 9999		
Default					
8.2 Analogue output.					
Current output					
Cali low		mA	0.0 - 20,0		
Cali high		mA	0.0 - 20,0		
Default					
8.3 Cond. range			Meas.1: 0,5-50 µS/cm Meas.2: 2-200 µS/cm Meas.3: 20-2000 µS/cm Meas.4: 100-10000 µS/cm	2 - 200	

Parameter	Function	Format/ Unit	Selection/ Limit	Default setting	Individual setting
<b>9 Settings</b>					
9.1 t-delay-LIM	time-delayed release of conductivity fault	xxx min	0 - 999	5	
9.2 t-delay-WAR	time-delayed release of conductivity warning	xxx min	0 - 999	1	
9.3 t-low-press	time-delayed release of fault pressure loss	xxx s	0 - 999	1 (8) by 3-phase current	
9.4 t-press-start	starting delay of pump, if pressure is OK	xxx s	0 - 999	9.9	
9.5 t-press-exist	time-delayed release of fault pressure loss during start-up	xxx s	0 - 999	60	
9.6 t-rinse	rinse time discontinuous rinse	xxx min	0 - 999	0	
9.7 t-rinse-inter	rinse interval discontinuous rinse	xxx h	0 - 999	0	
9.8 t-concentrate	duration of concentrate rinse/ replacement	xxxx s	0 - 9999	300	
9.9 t-reject					
9.9.1 min.	min. time of permeate rejection start-up	xxx s	0 - 999	5	
9.9.2 max.	max. time of permeate rejection start-up	xxx min	0 - 999	60	
9.10 t-mainten	Maintenance interval (Operating-LED flashes)	xxxxxx h	0 - 999999	3500	
9.11 fault reset	Reset faults	- without Password - with Password		without Password	
9.12 Concentrate					
9.12.1 concentrate	rejection without pump, rinse with pump	- displacement - rinse		displacement	
9.12.2 select rinse	disc. rinse with pump, disc. rinse without pump	- with pump - without pump		with pump	
9.13 tank type	permeate valve is closed during disc. rinse by "no overflow"	- with overflow - no overflow		with overflow	
9.14 Inputs					
9.14.1 ext. Stop	cont. Type	- NC contact - NO contact		NC contact	
	text display	Individual adjustment for display message		forced stop	
	delay	xxx s	0 - 999	0	
9.14.2 drive protect	cont. Type	- NC contact - NO contact		NC contact	
	text display	Individual adjustment for display message		motor/hard water	
	delay	xxx s	0 - 999	0	
9.14.3 press. switch	cont. Type	- NC contact - NO contact		NC contact	
	text display	Individual adjustment for display message		low pressure	

Parameter	Function	Format/ Unit	Selection/ Limit	Default setting	Individual setting
9.14.4 low Level	cont. Type		- NC contact - NO contact	NC contact	
9.14.5 high level	cont. Type		- NC contact - NO contact	NC contact	
9.14.6 Uni-Input 1	cont. Type		- NC contact - NO contact	NO contact	
	text display		Individual adjustment for display message	Leertext	
	reaction		- none - alarm - stop - fault - rereset	none	
	activation		rejection production concentrate. discont. rinse disinfection forced stop always	0 0 0 0 0 0 0	
	delay		xxx s	0 - 999	0
9.14.7 Uni-Input 2	cont. Type		- NC contact - NO contact	NO contact	
	text display		Individual adjustment for display message	Leertext	
	reaction		- none - alarm - stop - fault - rereset	none	
	activation		rejection production concentrate. discont. rinse disinfection forced stop always	0 0 0 0 0 0 0	
	delay		xxx s	0 - 999	0

Parameter	Function	Format/ Unit	Selection/ Limit	Default setting	Individual setting
9.15 Uni-Output		rank full rejection production concentrate discont. rinse disinfection ext. Stop Uni-Input 1 Uni-Input 2 drive protection low pressure error conductivity always		0 0 0 0 0 0 0 0 0 0 0 0	
9.16 Language		- deutsch - english - francais - italiano - espagnol - portuges		deutsch	
9.17 Analogue output	Classification conductivity at 20mA	$\mu\text{S/cm}$	0 – 9999		
9.18 Syst.-Reset					
9.19 Cali.-Reset					
9.20 Lang-Reset			Reset of adjustable display messages to default settings		
9.21 Oper.-h-Reset If requested: password Super			Password not adjustable		
9.22 Perm. valve			- yes - no	yes	
9.23 Conc. valve			- yes - no	yes	
9.24 Equipment ID If requested: password Super			- 0000 - 1000	1000	
<b>10 Diagnosis</b>					
10.1 Digit. Inputs					
10.2 Digit. Outputs					
10.3 An. Outputs					
10.4 An. Inputs					



## 8 Operation of the installation by personnel

### 8.1 Changing the operating mode

During normal PRODUCTION, the *operating mode* can be changed by pressing the **ENTER** key (access to user menu). In the user menu, item 2 *Operating mode* has to be selected and confirmed with **ENTER**.



The operating modes screen is displayed, in which the desired *operating mode* can be selected with the **UP / DOWN** keys.



#### Note:

- From the PRODUCTION mode it is only possible to change to STOP. A direct change to DISINFECTION is not possible.
- From the DISINFECTION mode it is only possible to change to STOP. A direct change to PRODUCTION is not possible.

## 8.2 Parameterisation of the digital output

The *universal output* is parameterised by pressing the **ENTER** key (access to the user menu). In the user menu, item *9 Settings* has to be selected and confirmed with **ENTER**. The *user password* ('1234') must be entered when the request for password input is displayed.



The settings level screen is displayed. Select *15 Uni output*.

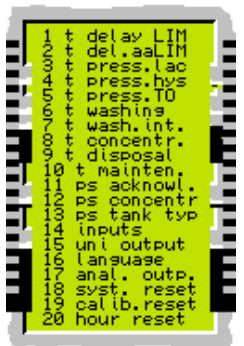

In the following screen the system status for the selected *universal output* has to be chosen.



The system status can be chosen as follows:

- *Tank full*
- *Rejection*
- *Production*
- *Concentrate rinse/displacement*
- *Disc. rinse*
- *Disinfection*
- *External Stop*
- *Uni input 1*
- *Uni input 2*
- *Motor protection fault*
- *Lack of pressure*
- *Conductivity fault*
- *Always active*

As all selectable parameterisations have equal priority, the user must make sure that the contact is already providing voltage (closed) when one parameter is met (connection using the logical “or” operation) when making the adjustments.

**Note!**

The unit connected to the universal output must have a sufficient protective circuit with an RC-varistor in order to prevent a fault in the controller.

### 8.3 Parameterisation of digital inputs

The *universal inputs* are parameterised by pressing the **ENTER** key (access to the user menu). In the user menu, item *9 Settings* has to be selected and confirmed with **ENTER**. The *user password* ('1234') must be entered when the request for password input is displayed.



The settings screen is displayed. Select *14 Inputs*.

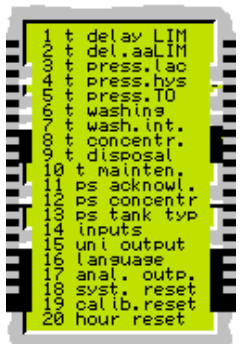

The inputs screen is displayed, in which *6 Uni input1* or *7 Uni input2* must be selected.

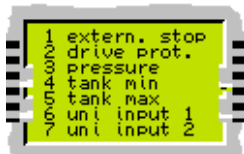

Now parameterise the *universal input* on the following screen.



The universal inputs must be parameterised as follows:

- *Contact type*: Selection of the connected contacts (*NO* or *NC*).
- *Message text*: Message text for active inputs can be set.
- *Reaction*: Selection of the installation reaction to be triggered:
  - *No reaction*
  - *Alarm*
  - *Stop (analogous to Tank full)*
  - *Fault/emergency stop*
  - *Request*
- *Activation*: Selection of the installation conditions that will initiate an analysis of the universal input:
  - *Rejection*
  - *Production*
  - *Concentrate rinse/displacement*
  - *Disc. rinse*
  - *Disinfection*
  - *External Stop*
  - *Always active*
- *Delay*: Adjustment of the delay for the activation of the input.

## 8.4 Parameterisation of standard inputs

The *standard inputs* (external Stop, level switch, pressure switch, motor protection switch) are parameterised by pressing the **ENTER** key (access to user menu). In the user menu, item 9 *Settings* has to be selected and confirmed with **ENTER**. The *user password* ('1234') must be entered when the request for password input is displayed.



The settings screen is displayed. Select *14 Inputs*.



The inputs screen is displayed, in which the input to be parameterised must be selected.

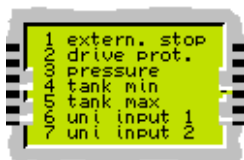

Now parameterise the *input* on the following screen.

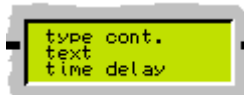

The *inputs* must be parameterised as follows:

- *Contact type*: Selection of the connected contacts (*NO* or *NC*).
- *Message text*: Programming of the message text possible if input is active (not available for MIN and MAX level!).
- *Delay*: Programming of the delay after input activation possible (not available for MIN and MAX level nor for pressure switch!)

## 8.5 Setting of conductivity and temperature limits

The *limits* are entered by pressing the **ENTER** key (access to the user menu). In the user menu, item 6 *Limits* has to be selected and confirmed with **ENTER**. The *user password* ('1234') must be entered when the request for password input is displayed.



The limits screen is displayed, in which the limit to be parameterised must be selected.

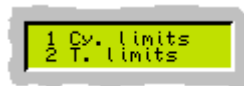

The *cond limits* must be parameterised as follows:

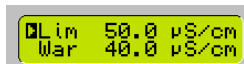

- *LIM*: if this limit is exceeded, a conductivity error is triggered, depending on the measuring range selected.
- *WAR*: if this limit is exceeded, a conductivity warning is triggered, depending on the limit range selected.

The *t limits* must be parameterised as follows:



- *T\_min*: if this minimum temperature is not reached, an alarm is triggered.
- *T\_max*: if this maximum temperature is exceeded, an alarm is triggered.

## 8.6 Setting the times

The *times* (rinse, rejection, lack of pressure, etc.) are parameterised by pressing the **ENTER** key (access to user menu). In the user menu, item *9 Settings* has to be selected and confirmed with **ENTER**. The *user password* ('1234') must be entered when the request for password input is displayed.

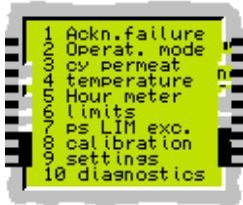

The settings screen is displayed, in which the *times* to be parameterised (parameters 1 to 10) must be selected.



The *times* must be parameterised as follows:

- *t-delay LIM*: setting of the delay before the conductivity alarm is triggered.
- *t-delay WAR*: setting of the delay before the conductivity pre-alarm is triggered.
- *t-low-press*: setting of the delay for initiation of the lack of pressure fault during operation
- *t-press-start*: setting of the priming delay for the **PUMP** 1P01 if there is pressure available
- *t-press-exist*: setting of the delay for initiation of the lack of pressure fault during priming
- *t-rinse*: setting of the duration of the discontinuous rinse
- *t-rinse-inter*: setting of the interval of the discontinuous rinse interval
- *t-concentrate*: setting of the duration of concentrate displacement/rinse
- *t-reject min*: setting of the minimum duration of rejection after start-up
- *t-reject max*: setting of the maximum duration of rejection after start-up
- *t-mainten*: setting of the maintenance interval, upon termination of which the **PRODUCTION** LED flashes.



## 8.7 Setting the selection parameters

The *parameters* (error display, tank type, etc.) are set by pressing the **ENTER** key (access to user menu). In the user menu, item *9 Settings* has to be selected and confirmed with **ENTER**. The *user password* ('1234') must be entered when the request for password input is displayed.

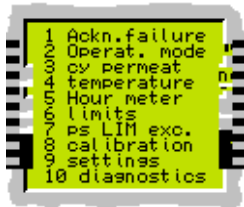

The settings screen is displayed, in which the *selection parameters* to be parameterised (parameters 11 to 13) must be selected.



The *selection parameters* must be parameterised as follows:

- *Fault reset*: Selection of acknowledgement type after fault indication.
  - *Without password*
  - *With password*
- *Concentrate*: selection options:
  - *Concentrate displacement* (without pump)
  - *Concentrate rinse* (with pump)
- *Tank type*: tank type selection:
  - *With overflow* (permeate valve opened during disc. rinse/ concentrate displacement/ concentrate rinse)
  - *Without overflow* (permeate valve closed during disc. rinse/ concentrate displacement/ concentrate rinse)

## 8.8 Selection of fault options

The *fault options* are parameterised by pressing the **ENTER** key (access to the user menu). In the user menu, item 7 *Fault options* has to be selected and confirmed with **ENTER**.



For the *fault options* the following parameters may be chosen:

- *Stop*: the installation is stopped if an alarm is active
- *Do not stop*: the installation remains in operation if an alarm is active.

### Note!

If the *cond perm* or *T permeate* alarm is active, the installation reacts immediately after detection of the fault; the alarm message, however, is displayed with the delay that has been set previously.

## 8.9 Carrying out a reset

To carry out a RESET (*system, calibration, language*), press the **ENTER** key (access to user menu). In the user menu, item *9 Settings* has to be selected and confirmed with **ENTER**. The *user password* ('1234') must be entered when the request for password input is displayed.



The settings screen is displayed, in which the *reset* to be carried out (parameters 18 to 20) must be selected.

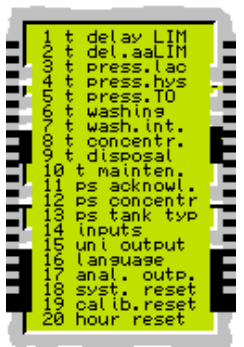

### System (syst. reset)

This menu option allows the controller to be RESET to factory settings from any installation mode.

### Calibration (calib reset):

The sensors of the controller have been calibrated to standard values at delivery. These standard values must be adapted manually to local requirements. If these calibration data have been modified and should then be reset to standard settings, a calibration RESET must be carried out.

### Language (lang reset):

This menu option allows the messages parameterised for the universal inputs to be RESET to the language selected.

## 8.10 Measuring and calibrating

Measuring and calibrating the sensors is carried out by pressing the **ENTER** key (access to the user menu). In the user menu, item 8 *Calibration* has to be selected and confirmed with **ENTER**. The *user password* ('1234') must be entered when the request for password input is displayed.

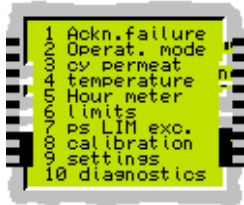

On the screen now displayed, select whether the analogue input or the analogue output should be calibrated. Select *1 ana inputs* to calibrate temperature and conductivity.

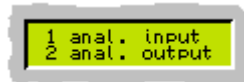

Now select whether to calibrate the permeate temperature or the permeate conductivity. After the analogue input to be calibrated has been selected and confirmed with **ENTER**, the following options are available:

- *lower point*: input of the reference conductivity/temperature currently measured as the lower reference point for the conductivity/temperature measurement. Disconnect the green wire of the measurement cell, then wait for 30 seconds and confirm with **ENTER**.



- *upper point*: input of the currently measured reference conductivity/temperature as the upper reference point for the conductivity/temperature measurement; note that this value must lie within the upper measuring range. Reconnect the green wire of the measurement cell. Wait 30 seconds before entering the value measured with the reference meter and confirming with **ENTER**.



- *Standard*: reset the reference points to factory settings



### Note!

The sensors have to be recalibrated once a year!

## 8.11 Diagnosis

The installation *diagnosis* is carried out by pressing the key **ENTER** (access to the user menu). In the user menu, item *10 Diagnosis* has to be selected and confirmed with **ENTER**. The *user password* ('1234') must be entered when the request for password input is displayed.



The diagnosis screen is displayed. Select which input should be monitored or which input should be manipulated.

These submenus make it possible to test all the inputs and outputs of the controller and therefore also to control the softener manually.

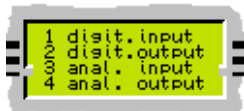

### Digital inputs (digit.inputs):

The operating modes of the inputs *external Stop*, *motor protection*, *pressure switch*, *level min.*, *level max.*, and *universal output*.

### Digital output (digit.outputs):

The outputs of the controller are displayed and controlled. Chose an output with the cursor key in order to control it (the output designation is shown in plain text). It can be controlled with the cursor keys **UP** and **DOWN**.

### **Caution!**

The units connected to the controller outputs are triggered without any safety devices if the respective output is actuated in diagnosis mode!

Analogue input (ana inputs):

The analogue measuring values of the installation are displayed.

Analogue output (ana output):

Display and control of the analogue output. The output is controlled with the cursor keys.

Closing the “Diagnosis” option:

After all the inputs and outputs desired have been tested the operator can return to the main menu pressing the **ESC** key. The control will then be in the same position as it was when the diagnosis menu was entered even if the various screens have been left with changed settings during *diagnosis*.

## 9 Malfunctions and their elimination

### 9.1 Indication and acknowledgement

The current, non-acknowledged error messages are displayed in an error screen.

Functional sequence in case of MALFUNCTION:

- The LED **FAULT** at the controller front panel is lit.
- The **ERROR OUTPUT** is activated.
- The function key **ESC** is attributed to the function “*Acknowledge acoustic alarm*”.

After the *acknowledgement of the acoustic alarm (ESC)*:

- The **ERROR OUTPUT** is reset.
- The acknowledged error messages are erased from the error screen.

If all error messages have been acknowledged individually by pressing the **ESC** key,

- the system changes to standard display (scrolling automatically through the display screens).

### 9.2 Description of and search for malfunctions

#### 9.2.1 Lack of pressure

During operation, this alarm is triggered with a delay if there is a lack of pressure (P9.3 and P9.5).

<b>Cause</b>	<b>Remedy</b>
Feed water pressure too low	- Check pressure difference at the water softener - Increase feed water pressure
Filter clogged	Exchange filter cartridge
Pressure switch defective	Replace pressure switch
Inlet valve 1V01 defective	Replace valve

The installation starts up again automatically after 1 minute. If the alarm occurs again, the delay is doubled until 32 minute max is reached.  
This time delay can be reset with ESC.

### 9.2.2 Motor failure / Hard water

The signalling contact of the **MOTOR PROTECTION SWITCH** is evaluated in combination with the signalling contact of the **HARD WATER SENSOR** (NC contacts connected in series). If no signal is emitted, this alarm is triggered.

Cause	Remedy
Hard water sensor triggered (if any)	- Check soft water quality - Check sensor and replace if necessary
Jumper defective	Repair jumper
Motor protection switch triggered (if any)	- Check motor protection switch settings - Check motor

### 9.2.3 Conductivity warning

The permeate conductivity is monitored against two limits. If the first limit is exceeded, a warning is displayed.

Cause	Remedy
Feed water conductivity too high	Calculate demineralisation rate Nominal: >97%
Demineralisation rate too low	After consulting the manufacturer - Clean modules - Replace modules

### 9.2.4 Conductivity exceeded

The permeate conductivity is monitored against two limits. If the second limit is exceeded, an error message is displayed and the permeate valve 1V02 is closed.

Cause	Remedy
Feed water conductivity too high	Calculate demineralisation rate Nominal: >97%
Demineralisation rate too low	After consulting the manufacturer - Clean modules - Replace modules

### 9.2.5 Rejection time exceeded

The duration of the rejection phase is monitored by parameter 9.9.2. If the monitored duration is exceeded, an alarm message is displayed.



## 9.2.6 Temperature fault

The temperature is monitored against parameterisable upper (P6.2.1) and lower (P6.2.2) limits. If the lower limit is not reached or the upper limit is exceeded, an alarm message is displayed.

## 9.2.7 External Stop

The **EXTERNAL STOP** inlet allows the installation to be switched off (analogous to Tank full). If the **EXTERNAL STOP** is activated, the message EXTERNAL STOP is displayed.

## 9.2.8 External stop (Tank full)

If one of the two digital **UNIVERSAL INPUTS** is parameterised to “*switch-off*” and the **UNIVERSAL INPUT** is active for a longer period than has been set for the delay, this message is displayed.

## 9.2.9 External emergency stop

If one of the two digital **UNIVERSAL INPUTS** is parameterised to “*emergency switch-off*” and the **UNIVERSAL INPUT** is active for a longer period than has been set for the delay, this message is displayed.

## 10 Disposal

Please consider the local regulations!

# 11 Technical Appendices

## 11.1 Technical data

<b>Type 230VAC (Item. 545376, 545377)</b>	
Mains electricity	207-253 VAC 50/60 Hz
Fuses	- Fuse electronics (SI 1) 630 mAT - Fuse mains output (SI 2) 6,3 AT
<b>Type 24VDC (Item. 545378)</b>	
Mains electricity	207-253 VAC 50/60 Hz
Fuses	- Fuse electronics (SI 1) 2 AT - Fuse mains output (SI 2) 6,3 AT
Protection category top-mount casing	IP 65
Protection category built-in casing	IP 54
Ambient temperature	0-40°C
Display	Text display 2x16 characters
Keypad	6 keys
LEDs	- Operation (green) - Fault (red) - Disinfection (yellow) - Rejection (yellow) - External Stop (yellow) - Tank full (yellow)
Terminals	Spring-loaded terminals - 5 mm for supply, outputs - 2.54 mm for inputs, pulse output
Interfaces	- RS232 as 6 pole male multipin plug in the terminal block, not galvanically isolated for diagnosis and service purposes
Inputs	- Supply voltage - External Stop - Motor protection/hard water - Pressure switch - Min. level - Max. level - Universal input 1 - Universal input 2 - Conductivity/temperature sensor
Outputs	- Mains output max. 100W - Pump - Inlet solenoid valve - Permeate solenoid valve - Concentrate solenoid valve - Universal output 1

## 11.2 Overview of the menu

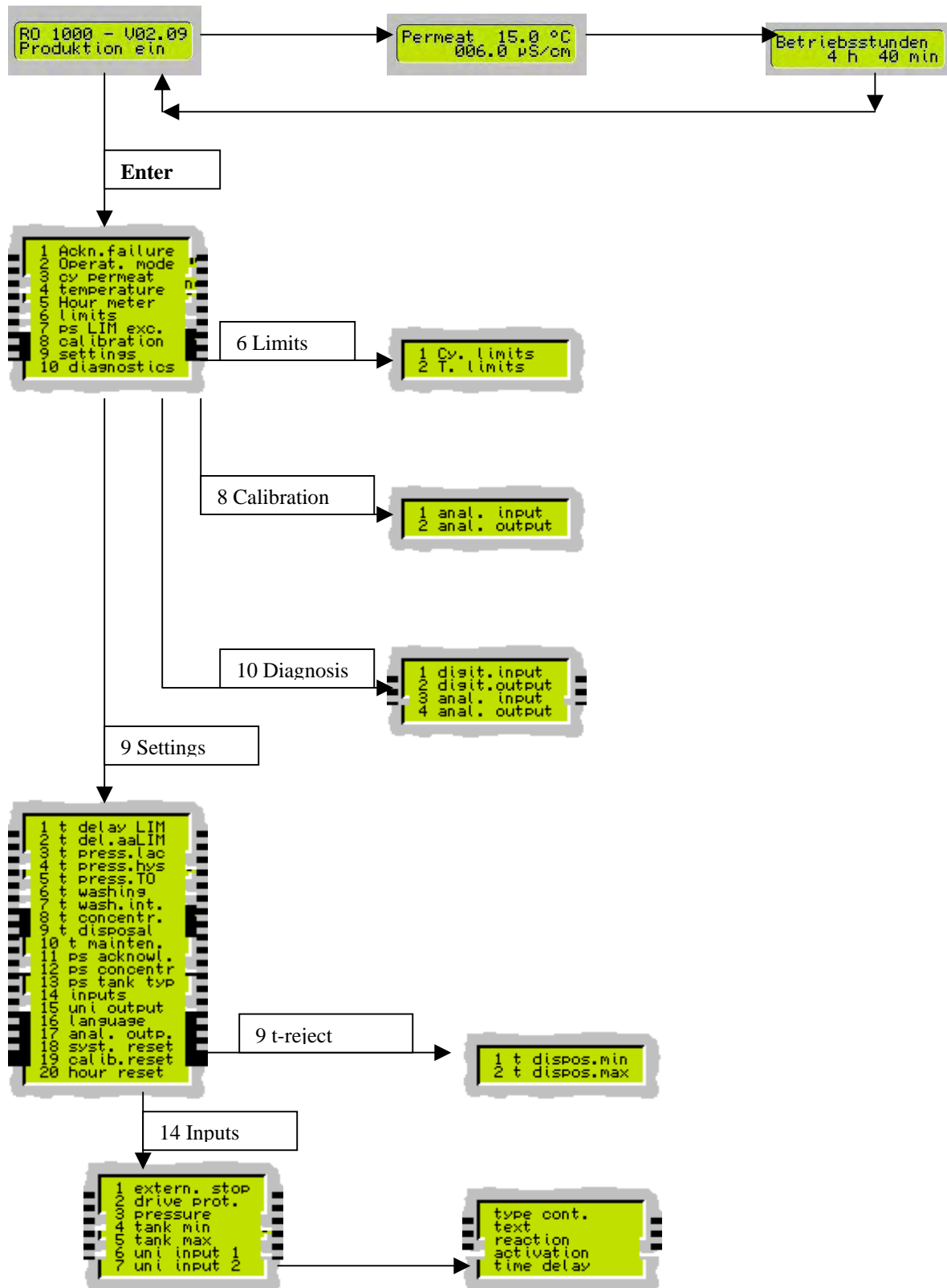



### Setting data RO 1000 V2.xx

Parameter	Function	Format/ Unit	Selection/ Limit	RS	ND	UO-ED	AS	ES	UP
<b>6 Limits</b>									
6.1 Cond.-limits									
6.1.1 GW	fault conductivity			50	50	50	50	50	20
6.1.2 GWV	warning conductivity			40	40	40	40	40	15
6.2 T-Grenzen									
6.2.1 T_min	Minimum Temperature	xx.x °C	0.0 - 99,9	5	5	5	5	5	5
6.2.2 T_max	Maximum Temperature	xx.x °C	0.0 - 99,9	40	40	40	40	40	40
<b>7 Alarm options</b>									
7.1 Conductivity		- stop - do not stop		do not stop	do not stop	do not stop	do not stop	do not stop	do not stop
7.2 Temperature		- stop - do not stop		do not stop	do not stop	do not stop	do not stop	do not stop	do not stop
<b>8 Calibration</b>									
8.3 Cond. range		Meas.1: 0,5-50 µS/cm Meas.2: 2-200 µS/cm Meas.3: 20-2000 µS/cm Meas.4: 100-10000 µS/cm		2-200	2-200	2-200	2-200	2-200	2-200
<b>9 Settings</b>									
9.1 t-delay-LIM	time-delayed release of conductivity fault	xxx min	0 - 999	5	5	5	5	5	5
9.2 t-delay-WAR	time-delayed release of conductivity warning	xxx min	0 - 999	1	1	1	1	1	1
9.3 t-low-press	time-delayed release of fault pressure loss	xxx s	0 - 999	1	<= 0,55kW: 1s >= 1,1kW: 8s	8	8	8	8
9.4 t-press-start	starting delay of pump, if pressure is OK	xxx s	0 - 999	10	10	10	10	10	10
9.5 t-press-exist	time-delayed release of fault pressure loss during start-up	xxx s	0 - 999	60	60	60	60	60	60

### Setting data RO 1000 V2.xx

Parameter	Function	Format/ Unit	Selection/ Limit	RS	ND	UO-ED	AS	ES	UP
9.6 t-rinse	rinse time discontinuous rinse	xxx min	0 - 999	0	0	0	0	0	0
9.7 t-rinse-inter	rinse interval discontinuous rinse	xxx h	0 - 999	0	0	0	0	0	0
9.8 t-concentrate	duration of concentrate rinse/ replacement	xxxx s	0 - 9999	300	300	600	300	300	300
9.9 t-reject									
9.9.1 min.	min. time of permeate rejection start-up	xxx s	0 - 999	5	5	5	5	5	5
9.9.2 max.	max. time of permeate rejection start-up	xxx min	0 - 999	60	60	60	60	60	60
9.10 t-mainten	Maintenance interval (Operating-LED flashes)	xxxxxx h	0 - 999999	3500	3500	3500	3500	3500	3500
9.11 fault reset	Reset faults	- without Password - with Password		without Password	without Password	without Password	without Password	without Password	without Password
9.12 Vw-Concentrat.									
9.12.1 concentrate	rejection without pump, rinse with pump	- displacement - rinse		displacement	displacement	rinse	displacement	displacement	displacement
9.12.2 select rinse	disc. rinse with pump, disc. rinse without pump	- with pump - without pump		with pump	with pump	with pump	with pump	with pump	with pump
9.13 tank type	permeate valve is closed during disc. rinse by "no overflow"	- with overflow - no overflow		with overflow	with overflow	with overflow	with overflow	with overflow	with overflow

### Setting data RO 1000 V2.xx

Parameter	Function	Format/ Unit	Selection/ Limit	RS	ND	UO-ED	AS	ES	UP
9.14 Inputs									
9.14.1 ext. Stop	cont. Type	- Öpener - Closer		Öpener	Öpener	Öpener	Öpener	Öpener	Öpener
	text display	Individual adjustment for display message		ext. Stop	ext. Stop	ext. Stop	ext. Stop	ext. Stop	ext. Stop
	delay	xxx s	0 - 999	0	0	0	0	0	0
9.14.2 drive protect	cont. Type	- Öpener - Closer		Öpener	Öpener	Öpener	Öpener	Öpener	Öpener
	text display	Individual adjustment for display message		motor/hard water	motor/hard water	motor/hard water	motor/hard water	motor/hard water	motor/hard water
	delay	xxx s	0 - 999	0	0	0	0	0	0
9.14.3 press. switch	cont. Type	- Öpener - Closer		Öpener	Öpener	Öpener	Öpener	Öpener	Öpener
	text display	Individual adjustment for display message		pressure deficit	pressure deficit	pressure deficit	pressure deficit	pressure deficit	pressure deficit
9.14.4 Niveau min	cont. Type	- Öpener - Closer		Öpener	Öpener	Öpener	Öpener	Öpener	Öpener
9.14.5 Niveau max	cont. Type	- Öpener - Closer		Öpener	Öpener	Öpener	Öpener	Öpener	Öpener
9.14.6 Uni-Eingang 1	cont. Type	- Öpener - Closer		Closer	Closer	Closer	Closer	Closer	Closer
	text display	Individual adjustment for display message							
	reaction	- none - alarm - stop (analog Tank full) - fault - requeset		none	none	none	none	none	none
	activation	rejection production concentrate. discont. rinse disinfection forced stop always		0 0 0 0 0 0 0	0 0 0 0 0 0 0	0 0 0 0 0 0 0	0 0 0 0 0 0 0	0 0 0 0 0 0 0	0 0 0 0 0 0 0
	delay	xxx s	0 - 999	0	0	0	0	0	0



### Setting data RO 1000 V2.xx

Parameter	Function	Format/ Unit	Selection/ Limit	RS	ND	UO-ED	AS	ES	UP
9.14.7 Uni-Input 2	cont. Type	- Öpener - Closer		Closer	Closer	Closer	Closer	Closer	Closer
	text display	Individual adjustment for display message							
	reaction	- none - alarm - stop (analog Tank full) - fault - reueset		none	none	none	none	none	none
	activation	rejection production concentrate. discont. rinse disinfection forced stop always		0 0 0 0 0 0 0	0 0 0 0 0 0 0	0 0 0 0 0 0 0	0 0 0 0 0 0 0	0 0 0 0 0 0 0	0 0 0 0 0 0 0
	delay	xxx s	0	0	0	0	0	0	0
9.15 Uni-Output		tank full rejection production concentrate discont. rinse disinfection ext. Stop Uni-Input 1 Uni-Input 2 drive protection low pressure error conductivity always		0 0 0 0 0 0 0 0 0 0 0 0 0	0 0 0 0 0 0 0 0 0 0 0 0 0	0 0 0 0 0 0 0 0 0 0 0 0 0	0 0 0 0 0 0 0 0 0 0 0 0 0	0 0 0 0 0 0 0 0 0 0 0 0 0	0 0 0 0 0 0 0 0 0 0 0 0 0
9.16 Language		- German - English - French - Spanish - Portuguese							

### Setting data RO 1000 V2.xx

Parameter	Function	Format/ Unit	Selection/ Limit	RS	ND	UO-ED	AS	ES	UP
9.17 Analogue output	Classification conductivity at 20mA	μS/cm	0 - 9999	200	200	200	200	200	200
9.22 Perm. valve		- yes - no		no	no	yes	no	no	yes
9.23 Conc. valve		- yes - no		no	no	no	yes	yes	no
9.24 Equipment ID If requested: password Super		- 0000 - 1000		1000	1000	1000	1000	1000	1000

\* Adjustment "yes" at option "concentrate rinse valve"

\*\* Adjustment "yes" at option "permeate recirculation"