



Construction

Vertical multi-stage pumps with suction and delivery connections of the same diameter and arranged along the same axis (in-line). Corrosion-resistant bearing sleeves lubricated by the pumped liquid. A pump with thrust bearing and sleeve coupling for use of any standard motor with IM V1 construction.

Version with frequency converter (on request)

Applications

For water supply systems.

For clean non-explosive liquids, without solid, filamentary or abrasive matter (with adaptation of sealing materials on request).

A universal pump for civil and industrial use, for pressure-boosting systems, fire-extinguishing systems, high-pressure washing plants, irrigation, agricultural uses and sport installations.

Operating conditions

Temperature of liquid: from -15 °C to +110 °C.

Operating environment temperature: up to 40 °C.

Maximum permissible pressure in pump casing: 25 bar.

Motor

Standard-type: 2-pole induction motor, 50 Hz (n ≈ 2900 rpm).

Construction IM V1 (EN 60034-7).

Motor suitable for operation with frequency converter.

Classification scheme IE3 for three-phase motors.

Insulation class F.

Protection IP 55.

three-phase with rated voltage: up to 3 kW 230/400 V;
from 4 kW 400/690 V.

The electropumps MXV series comply with the European Regulation no. 547/2012.

MXV 25, 32, 40

All parts that come into contact with the liquid, including wet-end covers, are in chrome-nickel stainless steel AISI 304.

Materials (wetted parts)

Component	Material
Flange	Stainless Steel 1.4301 EN 10088 (AISI 304)
External jacket	
Suction casing	
Delivery casing	
Stage casing	
Impeller	
Lower cover	
Upper cover	
Spacer sleeve	
Pump shaft	Stainless Steel 1.4305 EN 10088 (AISI 303)
Plug	
Bearing sleeve	Corrosion-resistant, cemented carbide Ceramic alumina
Bearing in stage casing	
Mechanical seal ISO 3069 - KU	Hard metal/Carbon/EPDM.
Wear ring	
O-rings	PTFE
	NBR

Direction of rotation: clockwise as seen from the motor.

Variants (to be specified when ordering)

- Pump with threaded ports (G).
- Pump with flanged ports (F).
- Pump without motor.
- Pump with standard motor.

Other variants (on request)

- With counter-flanges in chrome-nickel steel.
- O-rings FPM. Other mechanical seal.
- Pump with motor of Client's choice (if available).
- Single-phase motor 230 V, up to 2.2 kW.
- 4-pole induction motor (MXV4 series).
- Other voltage ratings.
- Frequency 60 Hz.

MXV 50, 65, 80, 100

Internal parts in contact with the liquid in chrome-nickel stainless steel, AISI 304 with pump casing and upper cover in cast iron.

Materials (wetted parts)

Component	Material
Pump casing	Cast iron GJL 250 EN 1561
Upper cover	
External jacket	Stainless Steel 1.4301 EN 10088 (AISI 304)
Stage casing	
Impeller	
Spacer sleeve	
Pump shaft	Stainless Steel (AISI 303)(AISI 431 for MXV 100) Stainless Steel (AISI 303)(AISI 304 for MXV 100)
Plug	
Bearing sleeve	Corrosion-resistant, cemented carbide Ceramic alumina (Corrosion-resistant, cemented carbide for MXV 100)
Bearing in stage casing	
Mechanical seal ISO 3069 - KU	Hard metal/Carbon/EPDM
Wear ring	
O-rings	NBR (EPDM for MXV 100)

Direction of rotation: anticlockwise as seen from the motor.
(clockwise as seen from the motor for MXV 100)

Variants (to be specified when ordering)

- Pump without motor.
- Pump with standard motor.

Other variants (on request)

- O-rings FPM. Other mechanical seal.
- Pump with motor of Client's choice (if available).
- Other voltage ratings.
- 4-pole induction motor (MXV4 series).
- Frequency 60 Hz.
- Pump with support feet for horizontal installation (H1 or H2).
- Support feet for horizontal installation, set.
- Welding counter-flanges, PN 25 (steel).

Pumps with frequency converter

The **MXV EI** pumps are available with power from 0,75 kW up to 22 kW, the pumps are equipped with **I-MAT** installed on board which allows to realize a variable-speed system extremely compact and efficient, ideal in applications of water supply and in the distribution of hot and cold water. The pump is equipped with transducers suitable for operation and is already programmed at the factory.

Advantages

- Energy saving
- Compact design
- Easy to use
- Programmable to suit the system requirements
- Reliability

Costruction

The system comprises of:

- Pump
- Induction motor
- I-MAT Frequency converter
- Motor adapter for the motor mounting of the frequency converter
- Connection cable between frequency converter and induction motor
- Transducers

Main features

- Rated motor power output from 0,75 kW to 22 kW
- Control range from 1750 to 2900 rpm (2-pole)
- Protection against dry running
- Protection against operations with closed connection ports
- Protection against system leakages
- Protection against overcurrent in the motor
- Protection against overvoltage and undervoltage of the power supply
- Protection against current unbalances between phases



Operating modes



Mode at a constant pressure with pressure sensor

In this mode, the system maintains the preset pressure when the flow required by the installation changes.

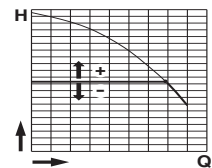

Proportional pressure mode with pressure sensor

In this mode the system changes the working pressure according to the required flow rate.

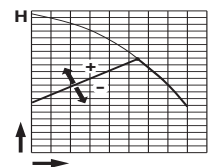

Constant flow mode with flow meter

In this mode the system maintains a constant flow rate value in a point of the installation according to the required pressure.

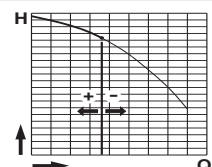

Fixed speed mode with setting of the speed preferential rotation.

In this mode, by changing the working frequency, you may choose any operational curve included within the working range.

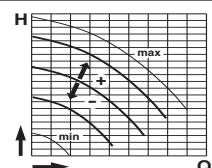

Constant temperature mode with temperature transducer

In this mode the system keeps the temperature constant inside a system by changing the speed of the pump.

MXV 25, 32, 40

Designation

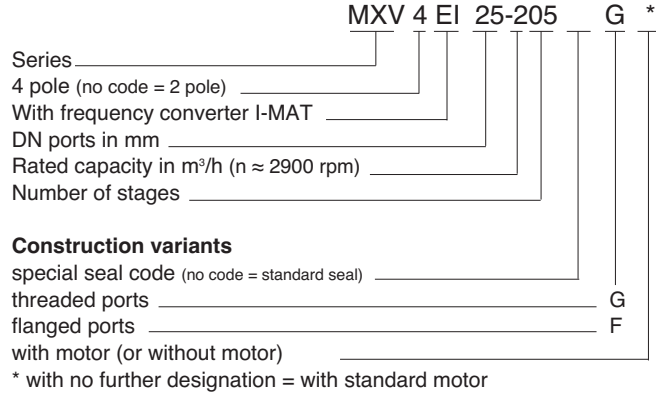

MXV 50, 65, 80, 100

Designation

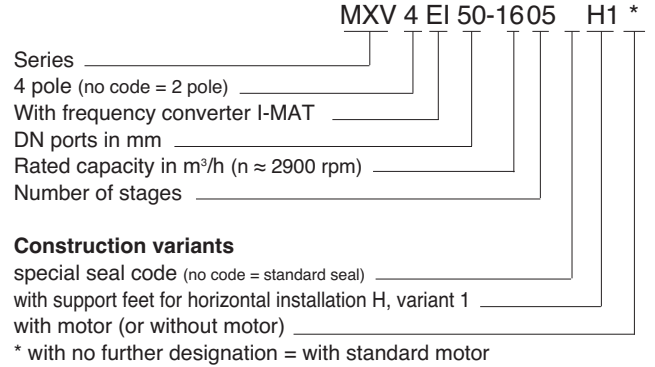

Pipe connection

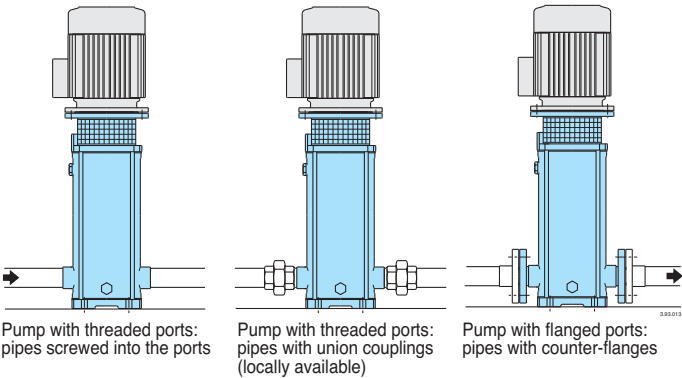

Installations

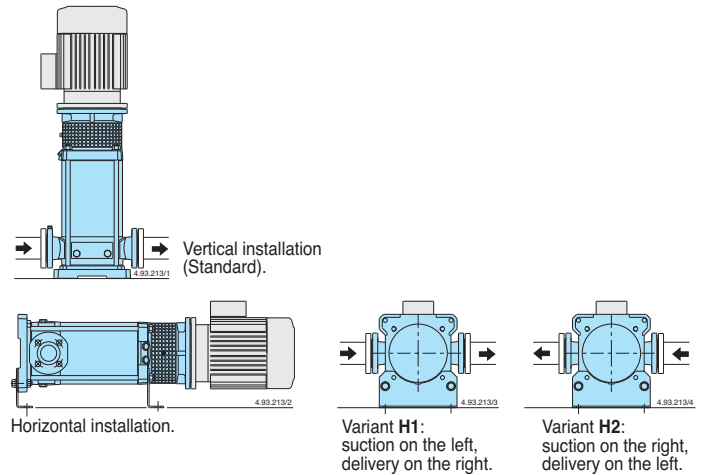

Variable parts

Pump size MXV - MXV4			Number of stages	Stage casings with bearing
25 - 204	32 - 404	40 - 804	4	1
25 - 205	32 - 405	40 - 805	5	1
25 - 206	32 - 406	40 - 806	6	1
25 - 207	32 - 407	40 - 807	7	1
25 - 208	32 - 408	40 - 808	8	1
25 - 210	32 - 410	40 - 810	10	1
25 - 212	32 - 412	40 - 811	11	2
		40 - 813	12	2
		40 - 815	13	2
25 - 214	32 - 414	40 - 815	14	2
25 - 216	32 - 416	40 - 815	15	2
		40 - 817	16	2
25 - 218	32 - 418	40 - 817	17	2
		40 - 819	18	2
25 - 220		40 - 817	17	3
		40 - 819	19	3
		40 - 819	20	3

Variable parts

Pump size MXV - MXV4			Number of stages	Stage casings with bearing
50 - 1603 50 - 1604 50 - 1605 50 - 1606 50 - 1607 50 - 1608 50 - 1609 50 - 1610	65 - 3202 65 - 3203 65 - 3204 65 - 3205 65 - 3206 65 - 3207	80 - 4801	1	1
		80 - 4802	2	1
		80 - 4803	3	1
		80 - 4804	4	1
		80 - 4805	5	1
			6	1
			7	1
			8	1
			9	1
			10	1
50 - 1611 50 - 1612 50 - 1614 50 - 1616	65 - 3208 65 - 3209 65 - 3210 65 - 3212	80 - 4806	6	2
		80 - 4807	7	2
		80 - 4808	8	2
			9	2
			10	2
			11	2
			12	2
			14	2
	16	2		

Coverage chart

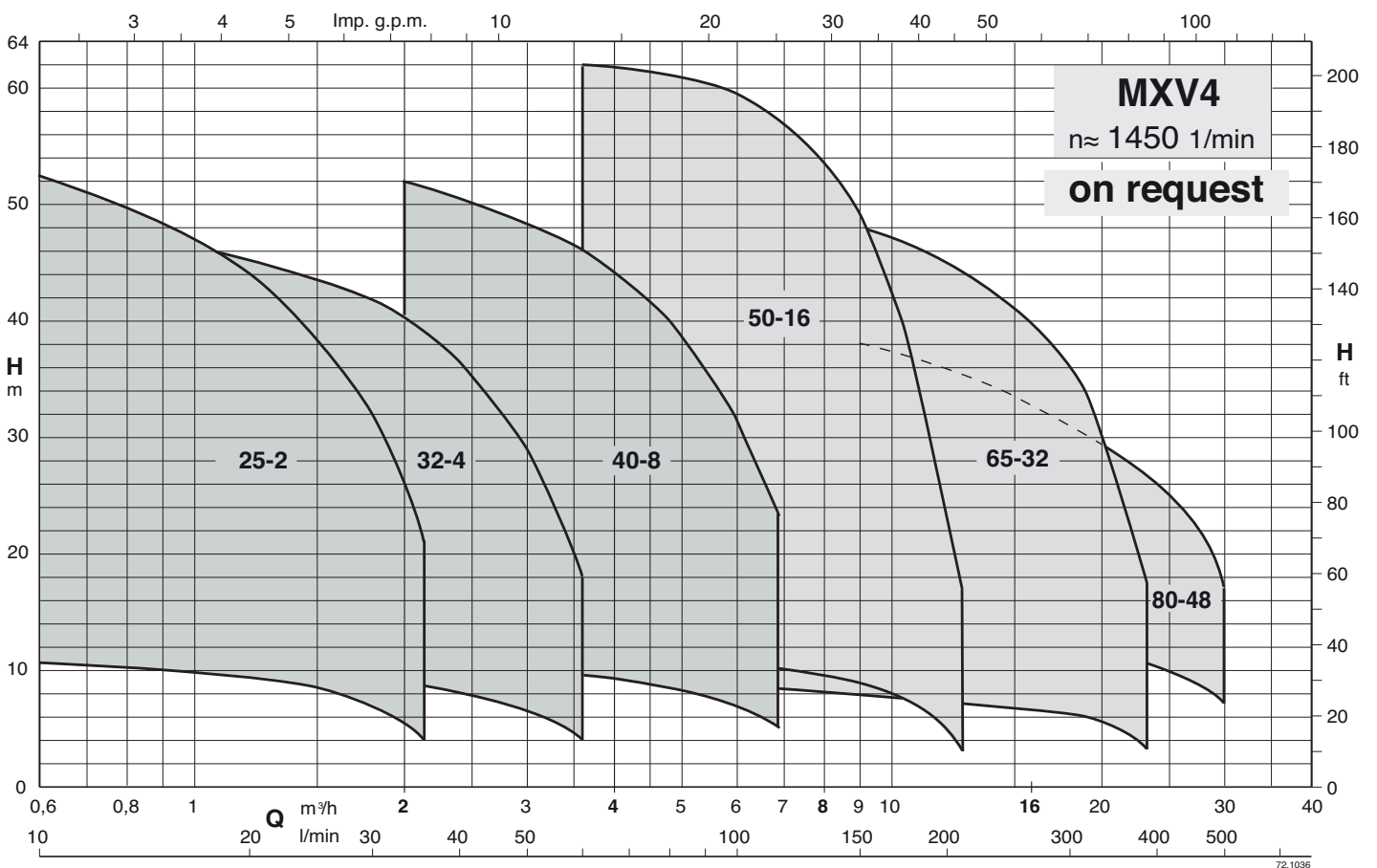
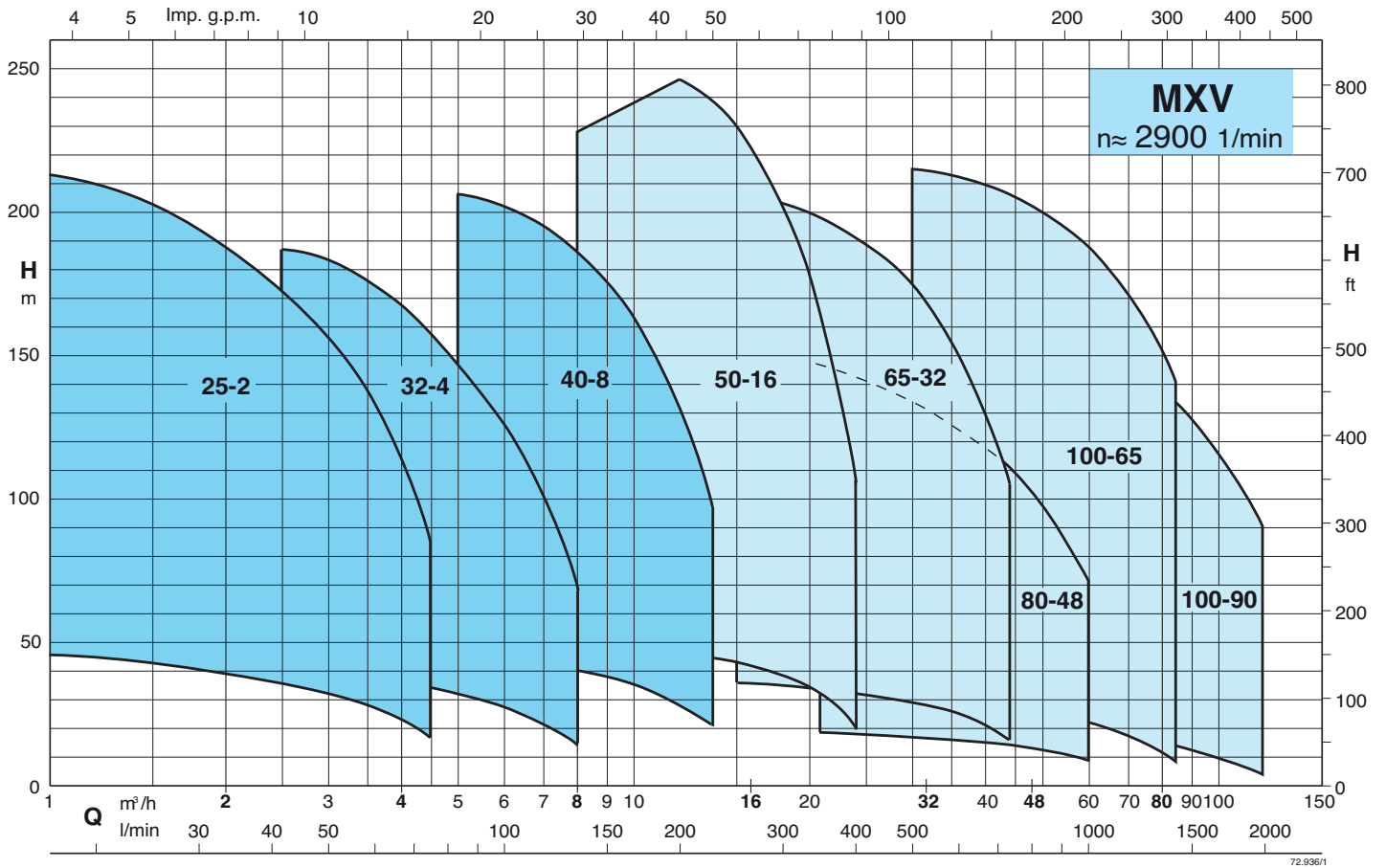

Characteristic curves and performance $n \approx 2900$ rpm

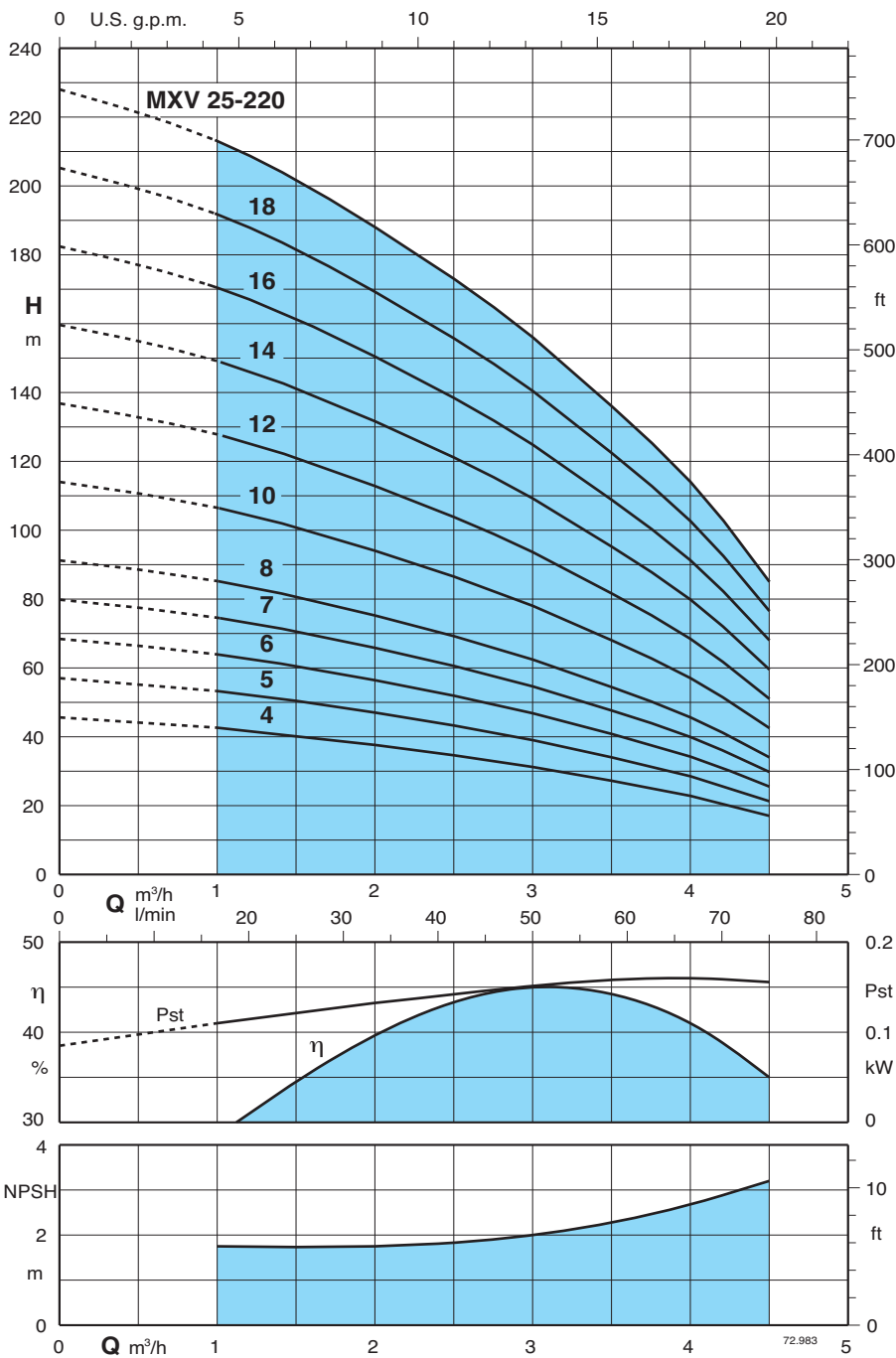

Test results with clean cold water, without gas content.

A safety margin of + 0.5 m is recommended for the NPSH value.

Tolerances in accordance with UNI EN ISO 9906:2012

Head and power values valid for liquids with density $\rho = 1,0 \text{ kg/dm}^3$ and kinematic viscosity $\nu = \text{max } 20 \text{ mm}^2/\text{sec}$.

Pst = Power with reference to one stage.

A* Calpeda motor currents

Pump type	230 V		400 V		Motor power		Q m³/h l/min	0	1	1,5	2	2,5	3	3,5	4	4,5
	A*	A*	kW	HP	kW	HP										
MXV 25-204/C	4	2,3	0,75	1	H m	0	0	16,6	25	33,3	41,6	50	58,3	66,6	75	
MXV 25-205/C	4	2,3	0,75	1		44	42,5	40	37,5	34,5	31	27	22,5	17		
MXV 25-206/D	4,7	2,7	1,1	1,5		56	53	50	47	43	39	34	28	21		
MXV 25-207/D	4,7	2,7	1,1	1,5		68	63,5	60,5	56	51,5	46,5	40,5	34	25		
MXV 25-208/D	7,4	4,3	1,5	2		79,5	74	70,5	65,5	60	54,5	47,5	39,5	30		
MXV 25-210/D	7,4	4,3	1,5	2		91	85	80,5	75	69	62	54	45,5	34		
MXV 25-212/D	9,2	5,3	2,2	3		114	106	101	94	86	78	68	57	42		
MXV 25-214/D	9,2	5,3	2,2	3		136	127	121	112	103	93,5	81,5	68	51		
MXV 25-216/C	11,4	6,6	3	4		159	149	141	131	121	109	95	79,5	59		
MXV 25-218/C	11,4	6,6	3	4		182	170	161	150	138	124	108	91	68		
MXV 25-220/C	11,4	6,6	3	4		205	191	181	169	155	140	122	102	76		
						228	213	202	188	173	156	136	114	85		

Characteristic curves and performance $n \approx 2900$ rpm

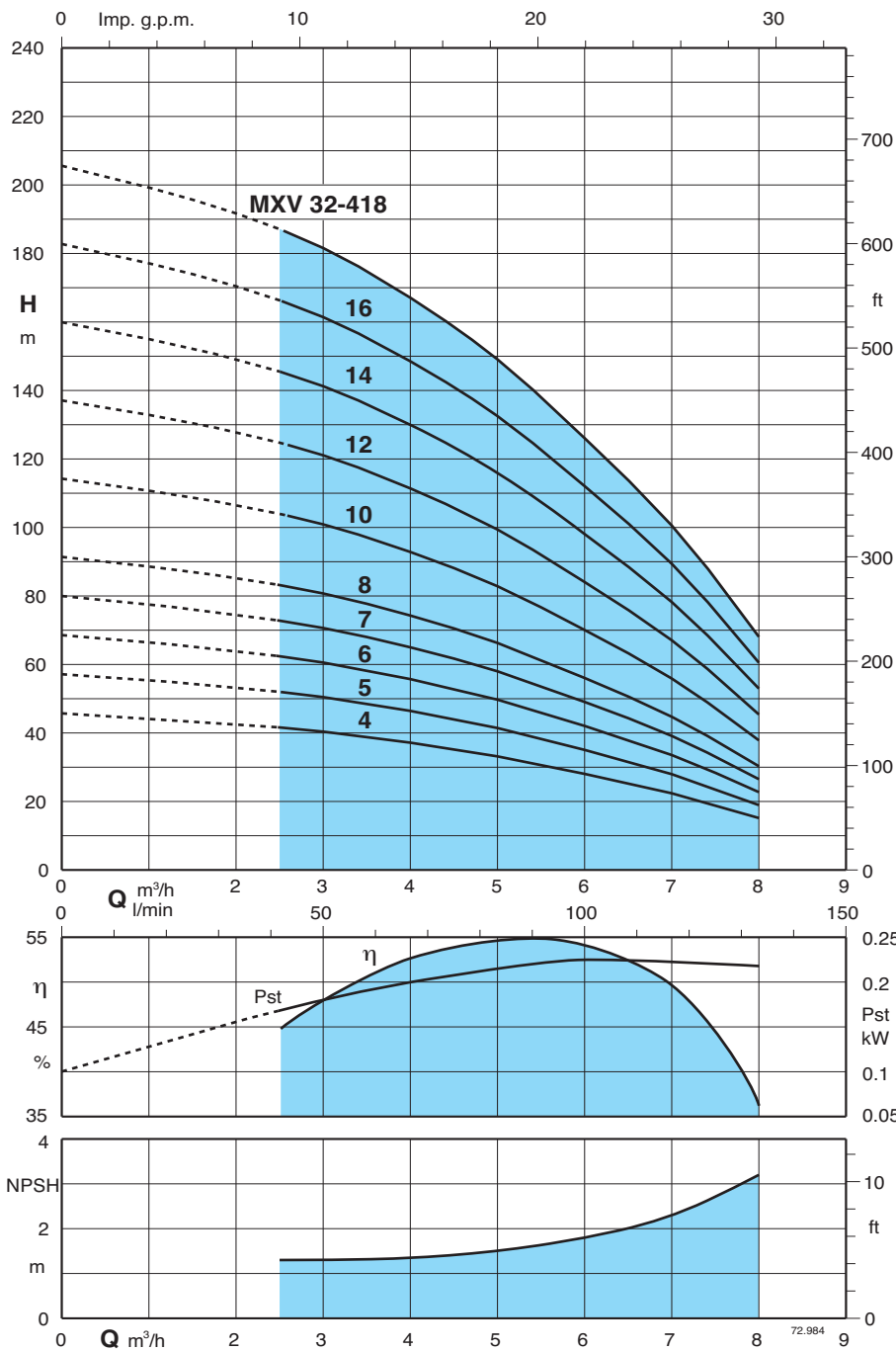

Test results with clean cold water, without gas content.
 A safety margin of + 0.5 m is recommended for the NPSH value.
 Tolerances in accordance with UNI EN ISO 9906:2012

Head and power values valid for liquids with density $\rho = 1,0 \text{ kg/dm}^3$ and kinematic viscosity $\nu = \text{max } 20 \text{ mm}^2/\text{sec}$.

Pst = Power with reference to one stage.
 A* Calpeda motor currents

Pump type	230 V		400 V		Motor power		Q m³/h l/min	H m										
	A*	A*	A*	A*	kW	HP		0	2,5	3	3,5	4	4,5	5	6	7	8	
MXV 32-404/D	4,7	2,7	1,1	1,5			0	41,6	50	58,3	66,6	75	83,3	100	116,6	133,3		
MXV 32-405/D	4,7	2,7	1,1	1,5			45	41,5	40	38,5	36,5	34,5	32,5	27,5	22	14,5		
MXV 32-406/D	7,4	4,3	1,5	2			56	51,5	50	48	46	43,5	41	34,5	27,5	18,5		
MXV 32-407/D	7,4	4,3	1,5	2			68	62	60	58	55,5	52,5	49,5	42	33,5	22,5		
MXV 32-408/D	9,2	5,3	2,2	3			79,5	72,5	70,5	68	65	61,5	58	49	39	26,5		
MXV 32-410/D	9,2	5,3	2,2	3			91	83	80,5	78	74	70	66	56	44,5	30		
MXV 32-412/C	11,4	6,6	3	4			114	104	101	97,5	93	88	83	70	56	38		
MXV 32-414/C	11,4	6,6	3	4			136	124	121	117	111	105	99,5	84	67	45,5		
MXV 32-416/D		9,6	4	5,5			159	145	141	136	130	123	116	98	78	53		
MXV 32-418/D		9,6	4	5,5			182	166	161	156	148	140	132	112	89,5	60,5		
							205	187	181	175	167	158	149	126	100	68		

Characteristic curves and performance $n \approx 2900$ rpm

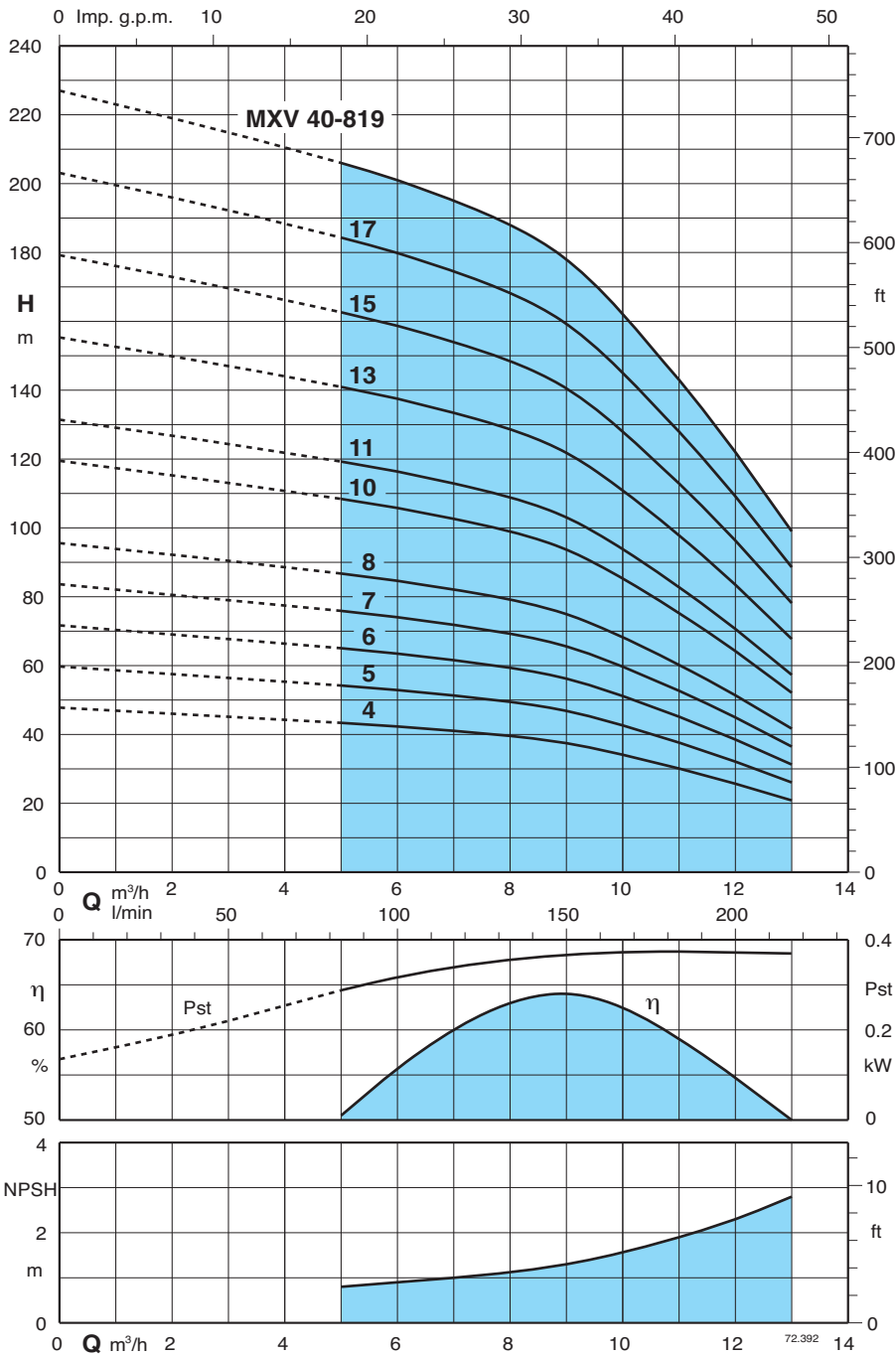

Test results with clean cold water, without gas content.

A safety margin of + 0.5 m is recommended for the NPSH value.

Tolerances in accordance with UNI EN ISO 9906:2012

Head and power values valid for liquids with density $\rho = 1,0 \text{ kg/dm}^3$ and kinematic viscosity $\nu = \text{max } 20 \text{ mm}^2/\text{sec}$.

Pst = Power with reference to one stage.

A* Calpeda motor currents

Pump type	230 V		400 V		Motor power		Q m³/h l/min	0	5	6	7	8	9	10	11	12	13
	A*	A*	kW	HP	kW	HP											
MXV 40-804/D	7,4	4,3	1,5	2			0	83,3	100	116,6	133,3	150	166,6	183,3	200	216,6	
MXV 40-805/D	9,2	5,3	2,2	3	H m		47	43	42	41	40	37	34	30	26	21	
MXV 40-806/D	9,2	5,3	2,2	3		59	54	53	51	50	47	43	38	32	26		
MXV 40-807/C	11,4	6,6	3	4		71	65	63	62	59	56	51	45	39	31		
MXV 40-808/C	11,4	6,6	3	4		83	76	74	72	69	66	60	53	45	36		
MXV 40-810/D		9,6	4	5,5		95	87	85	82	79	75	69	60	51	42		
MXV 40-811/D		9,6	4	5,5		119	109	106	103	99	94	86	75	64	52		
MXV 40-813/C		10,9	5,5	7,5		131	119	116	113	109	103	94	83	71	57		
MXV 40-815/C		10,9	5,5	7,5		155	141	138	134	129	122	111	98	84	68		
MXV 40-817/C		14,3	7,5	10		179	163	159	154	149	141	128	113	96	78		
MXV 40-819/C		14,3	7,5	10		202	184	180	175	168	159	145	128	109	89		
						226	206	201	195	188	178	162	143	122	99		

Characteristic curves and performance $n \approx 2900$ rpm

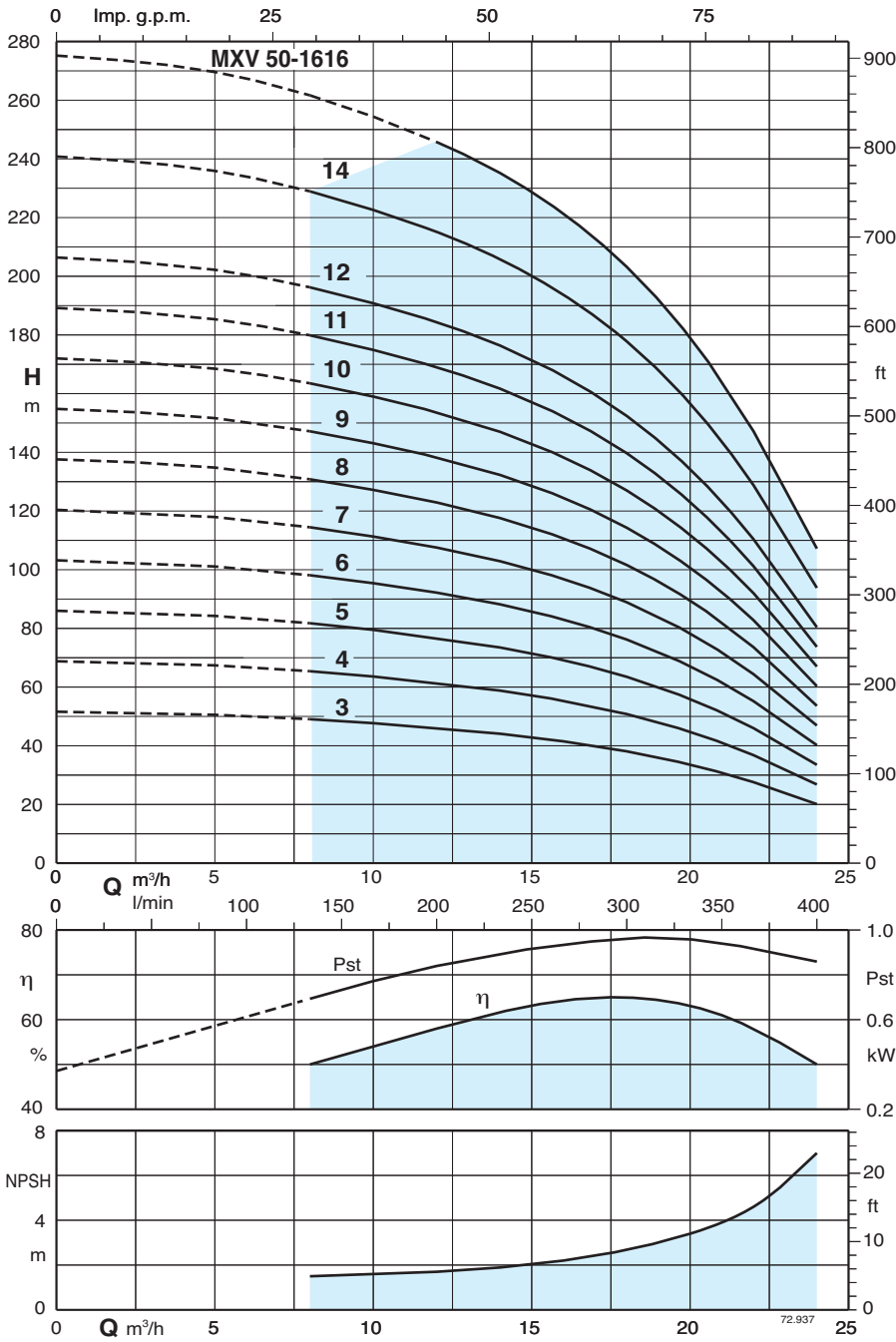

Test results with clean cold water, without gas content.

A safety margin of + 0.5 m is recommended for the NPSH value.

Tolerances in accordance with UNI EN ISO 9906:2012

Head and power values valid for liquids with density $\rho = 1,0 \text{ kg/dm}^3$ and kinematic viscosity $\nu = \text{max } 20 \text{ mm}^2/\text{sec}$.

Pst = Power with reference to one stage.

A* Calpeda motor currents

Pump type	230 V		400 V		Motor power		Q m³/h l/min	H m											
	A*	A*	A*	A*	kW	HP		0	8	10	12	14	16	18	20	22	24		
MXV 50-1603/C	11,4	6,6	3	4			0	8	10	12	14	16	18	20	22	24			
MXV 50-1604/D		9,6	4	5,5			0	133,3	166,6	200	233	266	300	333	366	400			
MXV 50-1605/C		10,9	5,5	7,5			51	49	48	46	44	41	38	33	27	20			
MXV 50-1606/C		10,9	5,5	7,5			69	65	63	61	59	55	51	44	37	27			
MXV 50-1607/C		14,3	7,5	10			86	81	79	76	73	69	63	55	46	33			
MXV 50-1608/C		14,3	7,5	10			103	98	95	92	88	83	76	67	55	40			
MXV 50-1609/D		21,5	11	15			120	114	111	107	103	97	89	78	64	47			
MXV 50-1610/D		21,5	11	15			138	130	127	122	117	110	101	89	73	53			
MXV 50-1611/D		21,5	11	15			155	147	143	138	132	124	114	100	83	60			
MXV 50-1612/D		27,3	15	20			172	163	159	153	147	138	127	111	92	67			
MXV 50-1614/D		27,3	15	20			189	179	175	168	161	152	139	122	101	73			
MXV 50-1616/D		34	18,5	25			206	196	190	184	176	166	152	133	110	80			
							240	228	222	214	206	193	178	156	129	94			
							275			245	235	221	203	178	147	107			

Characteristic curves and performance $n \approx 2900$ rpm

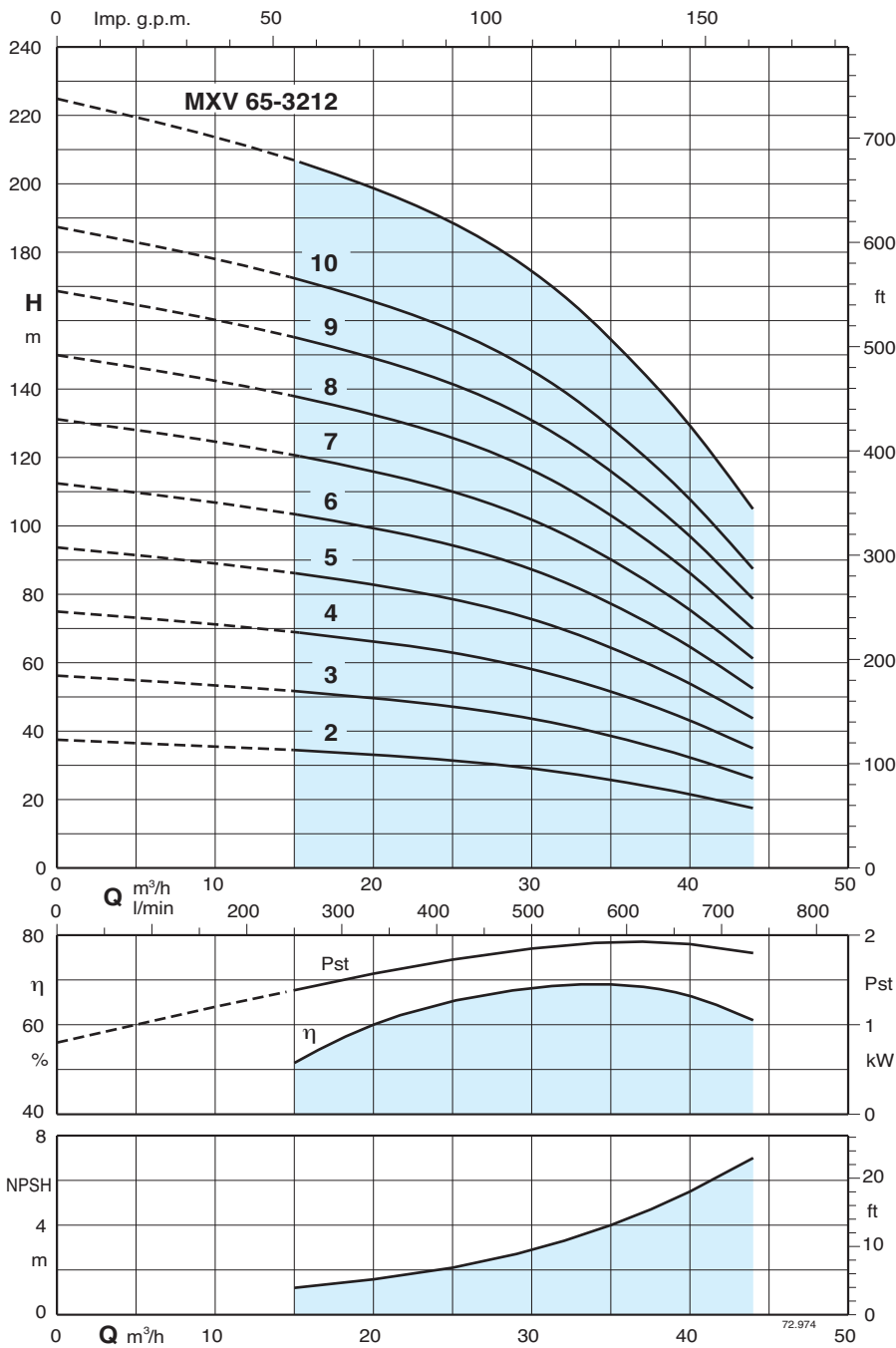

Test results with clean cold water, without gas content.

A safety margin of + 0.5 m is recommended for the NPSH value.

Tolerances in accordance with UNI EN ISO 9906:2012

Head and power values valid for liquids with density $\rho = 1,0 \text{ kg/dm}^3$ and kinematic viscosity $\nu = \text{max } 20 \text{ mm}^2/\text{sec}$.

Pst = Power with reference to one stage.

A* Calpeda motor currents

Pump type	230 V		400 V		Motor power		Q										
	A*	A*	kW	HP	m³/h	l/min	0	15	21	24	27	30	33	36	39	44	
MXV 65-3202/D			9,6	4	5,5		0	250	350	400	450	500	550	600	650	733	
MXV 65-3203/C			10,9	5,5	7,5		37	34	32	31	30	29	27	24,5	22	17	
MXV 65-3204/C			14,3	7,5	10		55,5	51	49	47,5	46	43,5	40,5	37	33,5	25,5	
MXV 65-3205/D			21,5	11	15		75	69	65,5	63,5	61	58,5	54,5	50	45	35	
MXV 65-3206/D			21,5	11	15		93,5	86	82	79,5	77	73	68	62,5	56,5	44	
MXV 65-3207/D			27,3	15	20		112	103	98,5	95,5	92	87	82	75	67,5	52,5	
MXV 65-3208/D			27,3	15	20		131	121	115	111	107	102	95,5	87,5	79	61,5	
MXV 65-3209/D			34	18,5	25		150	138	131	127	123	116	109	100	90	70	
MXV 65-3210/D			34	18,5	25		168	155	148	143	138	130	122	112	101	79	
MXV 65-3212/D			41	22	30		187	172	164	159	154	145	136	125	112	87,5	
							225	207	197	191	185	174	163	150	135	105	

Characteristic curves and performance $n \approx 2900$ rpm

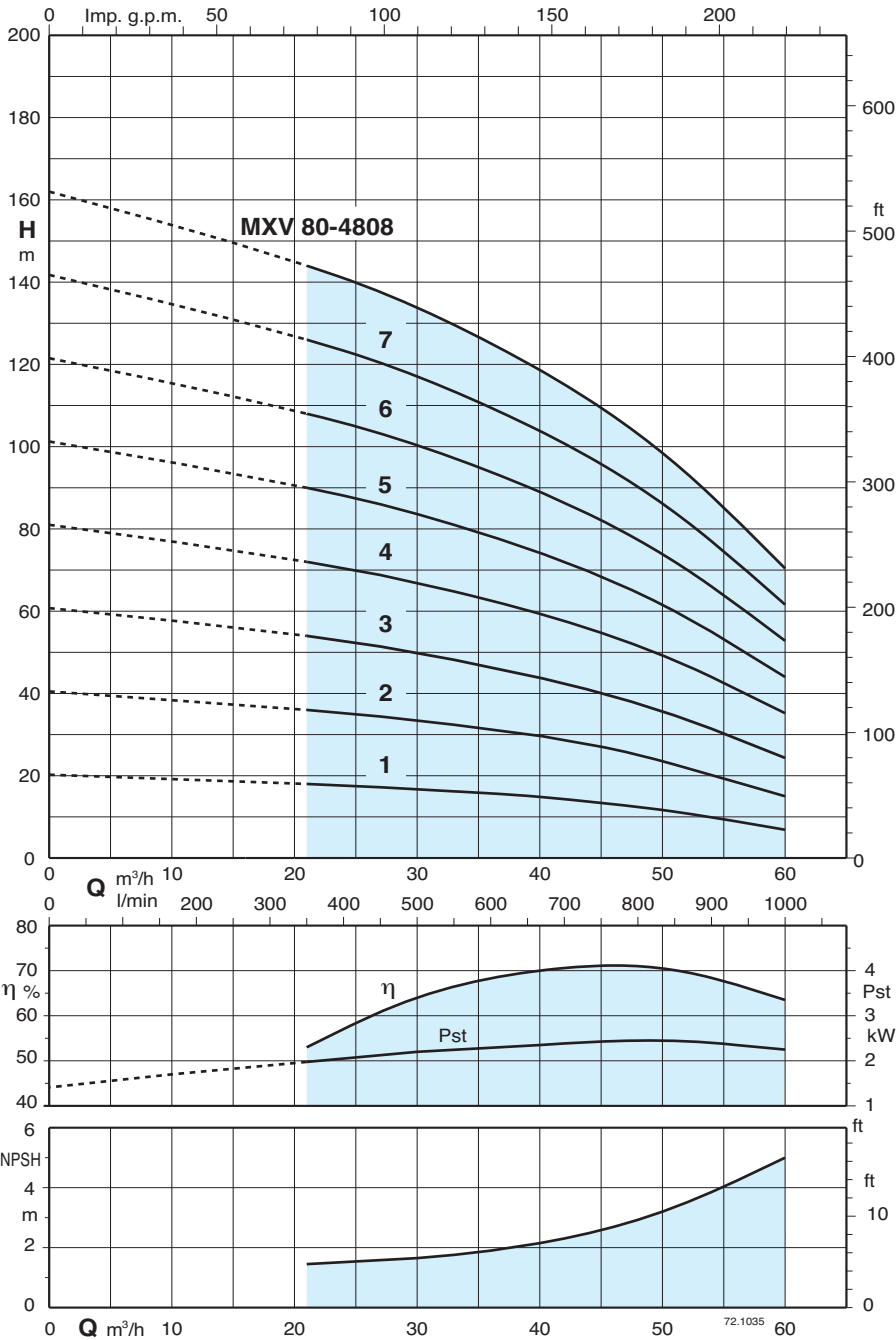

Test results with clean cold water, without gas content.

A safety margin of + 0.5 m is recommended for the NPSH value.

Tolerances in accordance with UNI EN ISO 9906:2012

Head and power values valid for liquids with density $\rho = 1,0 \text{ kg/dm}^3$ and kinematic viscosity $\nu = \text{max } 20 \text{ mm}^2/\text{sec}$.

Pst = Power with reference to one stage.

A* Calpeda motor currents

Pump type	230 V		400 V		Motor power		Q m³/h l/min	H m	0	21	27	33	39	45	48	51	54	60
	A*	A*	kW	HP	kW	HP												
MXV 80-4801/D			9,6	4	5,5		0	20	18	17	16	15	13	12	10,7	9,5	7	
MXV 80-4802/C			10,9	5,5	7,5		0	40,5	36	34,5	32,5	29,5	26,5	24,5	22	20	15,5	
MXV 80-4803/C			14,3	7,5	10		0	61	54	51	48	44	40	37	34	31	24,5	
MXV 80-4804/D			21,5	11	15		0	81	72	69	65	60	55	51,5	48	44	35	
MXV 80-4805/D			27,3	15	20		0	101	90	86	81	75	68,5	64,5	60	55	44	
MXV 80-4806/D			27,3	15	20		0	121	108	103	97	90	82	77,5	72	66	53	
MXV 80-4807/D			34	18,5	25		0	142	126	120	113	105	96	90	84	77	61,5	
MXV 80-4808/D			41	22	30		0	162	144	137	129	120	109	103	96	88	70,5	

Characteristic curves and performance $n \approx 2900$ rpm

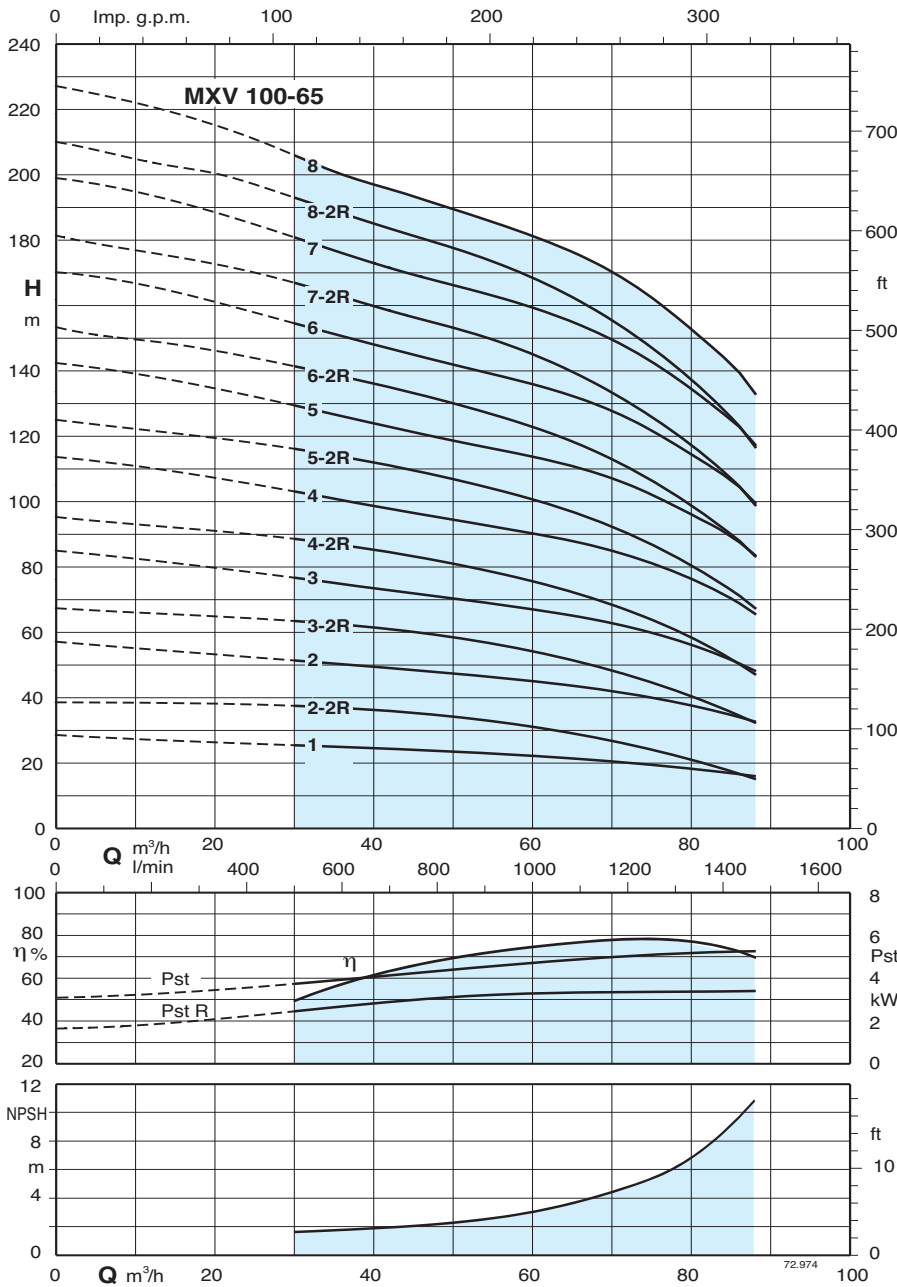

Test results with clean cold water, without gas content.
 A safety margin of + 0.5 m is recommended for the NPSH value.
 Tolerances in accordance with UNI EN ISO 9906:2012

Head and power values valid for liquids with density $\rho = 1,0 \text{ kg/dm}^3$ and kinematic viscosity $\nu = \text{max } 20 \text{ mm}^2/\text{sec}$.

Pst = Power with reference to one stage.
 A* Calpeda motor currents

Pump type	400 V A*	Motor power		Q m³/h l/min	H m											
		kW	HP		0	30	36	42	45	54	60	72	78	85		
MXV(L) 100-6501	10,9	5,5	7,5	0	28	25	24,5	24	23,5	22,5	22	20	18,5	16,5		
MXV(L) 100-6502-2R	14,3	7,5	10	30	39	37,5	36,5	35,5	35	33	31	25	22	17,5		
MXV(L) 100-6502	21,5	11	15	36	56,5	51	49,5	48,5	48	46	45	41	38,5	34,5		
MXV(L) 100-6503-2R	27,3	15	20	42	67,5	63,5	62	60,5	59,5	56,5	54	46,5	42	35,5		
MXV(L) 100-6503	34	18,5	25	45	84,5	76	74	72,5	71,5	69	67	61,5	57,5	51,5		
MXV(L) 100-6504-2R	34	18,5	25	54	95,5	88,5	86	84	83	79	75,5	66	60,5	52		
MXV(L) 100-6504	41	22	30	60	113	102	100	97,5	96,5	92,5	90,5	83	78	70		
MXV(L) 100-6505-2R	54	30	40	72	125	116	113	110	109	104	101	90	83	72,5		
MXV(L) 100-6505	54	30	40	78	142	129	125	122	121	116	114	105	98,5	88,5		
MXV(L) 100-6506-2R	54	30	40	85	153	141	137	134	133	127	123	110	102	89,5		
MXV(L) 100-6506	64	37	50	0	170	154	150	147	145	139	136	125	117	105		
MXV(L) 100-6507-2R	64	37	50	30	181	166	162	158	156	150	145	130	120	106		
MXV(L) 100-6507	77	45	60	36	199	180	175	172	169	163	159	147	138	124		
MXV(L) 100-6508-2R	77	45	60	42	210	193	188	184	181	174	168	152	141	125		
MXV(L) 100-6508	77	45	60	45	227	206	200	196	193	186	181	167	157	141		

Characteristic curves and performance $n \approx 2900$ rpm

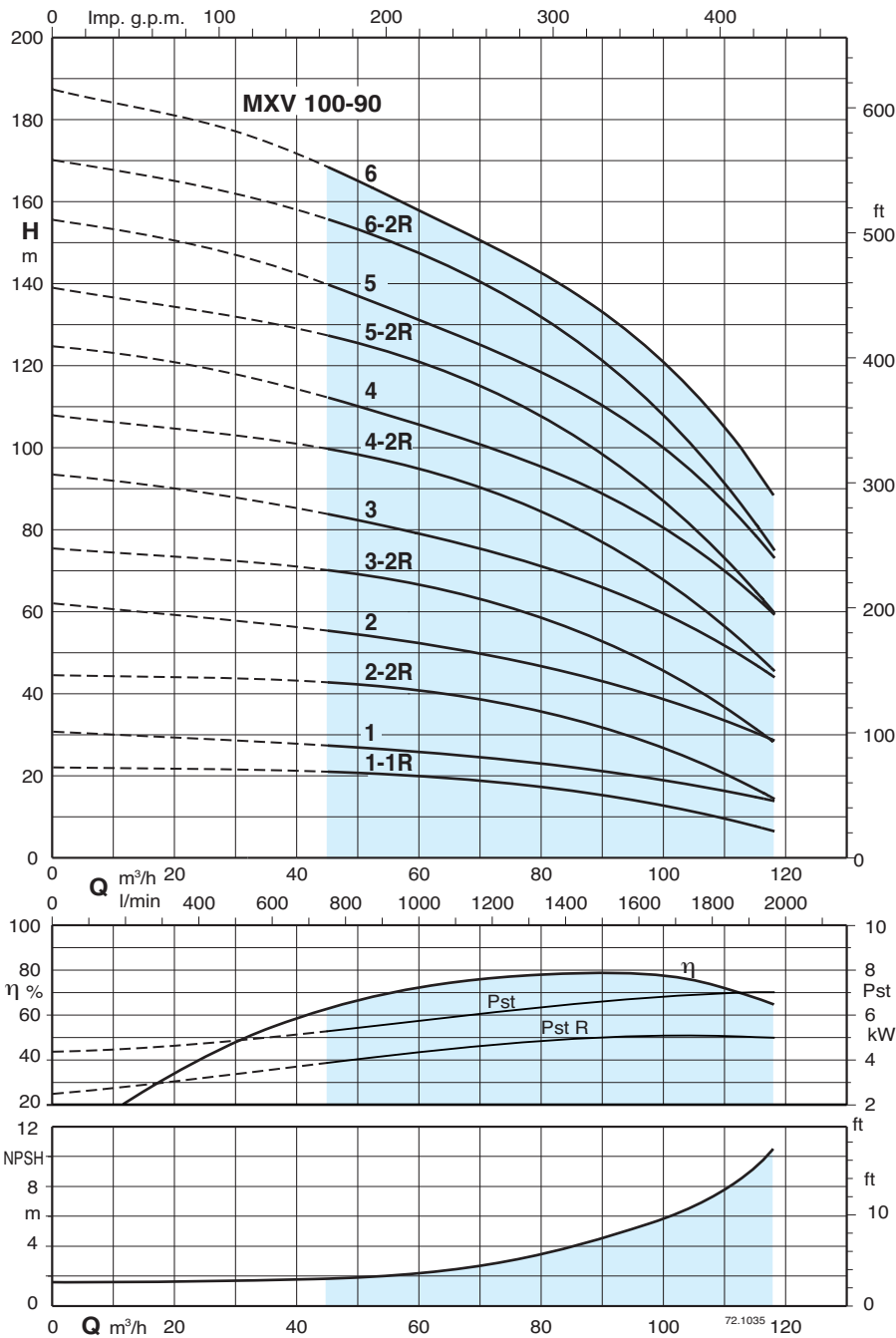

Test results with clean cold water, without gas content.

A safety margin of + 0.5 m is recommended for the NPSH value.

Tolerances in accordance with UNI EN ISO 9906:2012

Head and power values valid for liquids with density $\rho = 1,0 \text{ kg/dm}^3$ and kinematic viscosity $\nu = \text{max } 20 \text{ mm}^2/\text{sec}$.

Pst = Power with reference to one stage.

A* Calpeda motor currents

Pump type	400 V		Motor power	Q m³/h l/min	H m										
	A*	kW			HP	0	45	54	60	72	78	85	96	108	118
MXV(L) 100-9001-1R	10,9	5,5	7,5	0	0	750	900	1000	1200	1300	1417	1600	1800	1967	
MXV(L) 100-9001	14,3	7,5	10	22	21	20,5	20	19	17,5	16,5	13,5	10	6,5		
MXV(L) 100-9002-2R	21,5	11	15	30,5	27,5	26	25,5	24	23,5	22	20	17	13,5		
MXV(L) 100-9002	27,3	15	20	44,5	43	42	41	38,5	36,5	34	28,5	21,5	15		
MXV(L) 100-9003-2R	34	18,5	25	62	55,5	53	51,5	49	47,5	45	41	35	28,5		
MXV(L) 100-9003	41	22	30	75,5	70,5	68	66,5	62,5	59,5	56	48,5	38,5	28,5		
MXV(L) 100-9004-2R	54	30	40	93,5	84	80,5	78	74	72	69	62,5	53,5	44		
MXV(L) 100-9004	54	30	40	108	100	97	94,5	89	85,5	81	71,5	59	46		
MXV(L) 100-9005-2R	64	37	50	125	112	108	105	99,5	96,5	92,5	84	72	60		
MXV(L) 100-9005	64	37	50	139	127	123	120	113	109	103	92	76	60		
MXV(L) 100-9006-2R	77	45	60	156	140	134	130	123	120	114	104	89	74		
MXV(L) 100-9006	77	45	60	170	156	150	146	138	134	127	113	94,5	75,5		
MXV(L) 100-9006	77	45	60	188	169	161	157	149	144	138	126	108	89,5		

Dimensions and weights

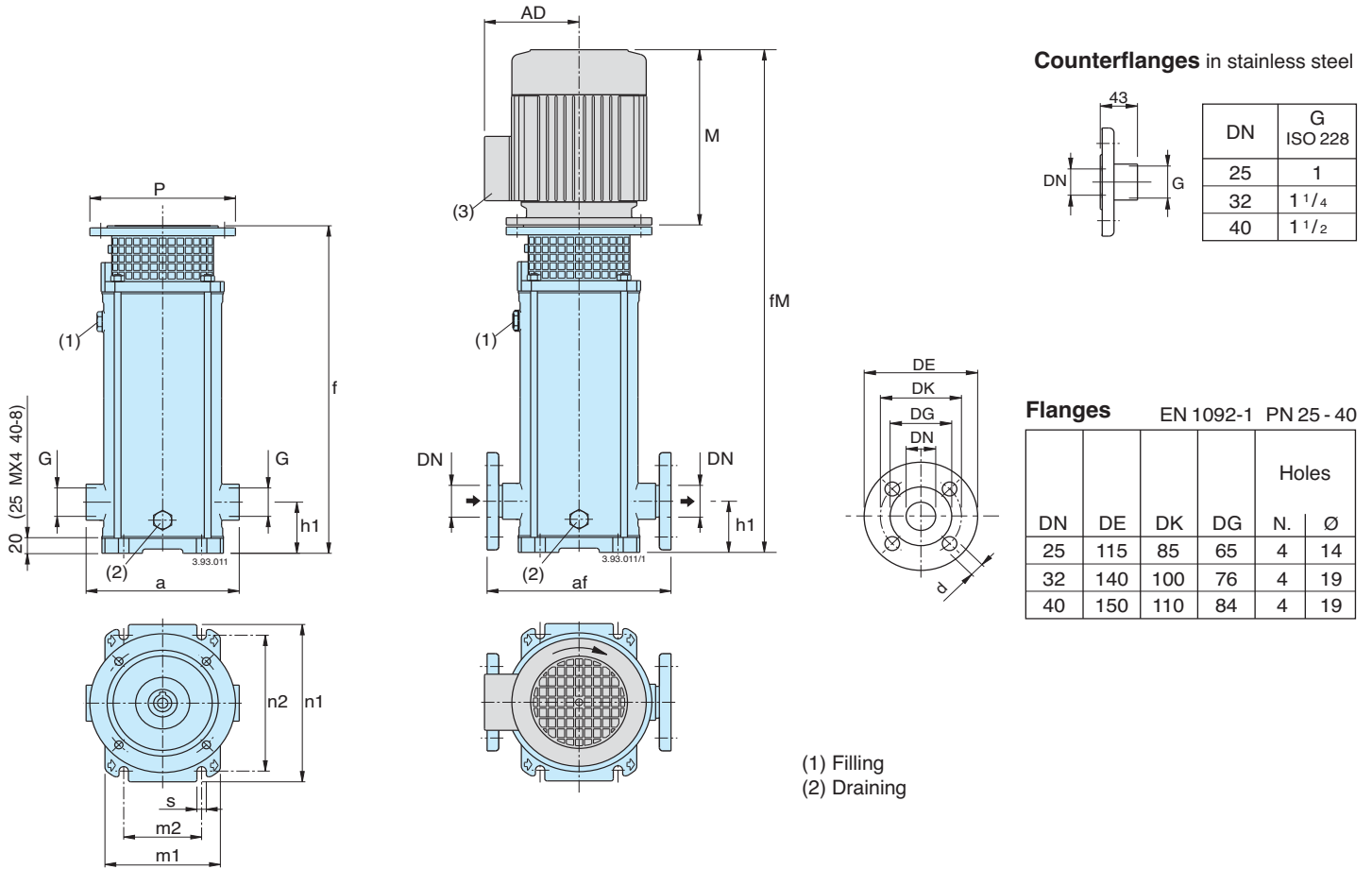

Pump	Motor		MXV (G) threaded ports		MXV (F) flanged ports		mm											without motor	with motor	
	kW	HP		G ISO 228	a	DN	af	h1	f	(5) M	fM	P	(5) AD	n1	n2	m1	m2	s	MXV (G) (4) kg(6)	(5) kg(6)
MXV 25-204/C	0,75	1	M80 V1	G1	215	25	250	75	372	255	627	200	127,5	210	180	150	100	12,5	18	30,2
MXV 25-205/C	0,75	1	M80 V1	G1	215	25	250	75	396	255	651	200	127,5	210	180	150	100	12,5	19	31,2
MXV 25-206/D	1,1	1,5	M80 V1	G1	215	25	250	75	420	255	675	200	127,5	210	180	150	100	12,5	20	33,3
MXV 25-207/D	1,1	1,5	M80 V1	G1	215	25	250	75	444	255	699	200	127,5	210	180	150	100	12,5	21	34,3
MXV 25-208/D	1,5	2	M90 V1	G1	215	25	250	75	478	255	733	200	127,5	210	180	150	100	12,5	22	37,2
MXV 25-210/D	1,5	2	M90 V1	G1	215	25	250	75	526	255	781	200	127,5	210	180	150	100	12,5	23	38,2
MXV 25-212/D	2,2	3	M90 V1	G1	215	25	250	75	574	295	869	200	127,5	210	180	150	100	12,5	25	43,1
MXV 25-214/D	2,2	3	M90 V1	G1	215	25	250	75	622	295	917	200	127,5	210	180	150	100	12,5	26	44,1
MXV 25-216/C	3	4	M100 V1	G1	215	25	250	75	680	311	991	250	137,5	210	180	150	100	12,5	29	54,6
MXV 25-218/C	3	4	M100 V1	G1	215	25	250	75	728	311	1039	250	137,5	210	180	150	100	12,5	31	56,6
MXV 25-220/C	3	4	M100 V1	G1	215	25	250	75	776	311	1087	250	137,5	210	180	150	100	12,5	32	57,6
MXV 32-404/D	1,1	1,5	M80 V1	G1 1/4	215	32	250	75	372	255	627	200	127,5	210	180	150	100	12,5	19	31,2
MXV 32-405/D	1,1	1,5	M80 V1	G1 1/4	215	32	250	75	396	255	651	200	127,5	210	180	150	100	12,5	20	32,2
MXV 32-406/D	1,5	2	M90 V1	G1 1/4	215	32	250	75	430	255	685	200	127,5	210	180	150	100	12,5	21	36,2
MXV 32-407/D	1,5	2	M90 V1	G1 1/4	215	32	250	75	454	255	709	200	127,5	210	180	150	100	12,5	22	37,2
MXV 32-408/D	2,2	3	M90 V1	G1 1/4	215	32	250	75	478	295	773	200	127,5	210	180	150	100	12,5	23	41,1
MXV 32-410/D	2,2	3	M90 V1	G1 1/4	215	32	250	75	526	295	821	200	127,5	210	180	150	100	12,5	24	42,1
MXV 32-412/C	3	4	M100 V1	G1 1/4	215	32	250	75	584	311	895	250	137,5	210	180	150	100	12,5	27	52,6
MXV 32-414/C	3	4	M100 V1	G1 1/4	215	32	250	75	632	311	943	250	137,5	210	180	150	100	12,5	29	54,6
MXV 32-416/D	4	5,5	M112 V1	G1 1/4	215	32	250	75	680	311	991	250	137,5	210	180	150	100	12,5	30	57,8
MXV 32-418/D	4	5,5	M112 V1	G1 1/4	215	32	250	75	728	311	1039	250	137,5	210	180	150	100	12,5	31	58,8
MXV 40-804/D	1,5	2	M90 V1	G1 1/2	225	40	280	80	411	255	666	200	127,5	246	215	190	130	14	21	36,2
MXV 40-805/D	2,2	3	M90 V1	G1 1/2	225	40	280	80	441	295	736	200	127,5	246	215	190	130	14	22	40,1
MXV 40-806/D	2,2	3	M90 V1	G1 1/2	225	40	280	80	471	295	766	200	127,5	246	215	190	130	14	23	41,1
MXV 40-807/C	3	4	M100 V1	G1 1/2	225	40	280	80	511	311	822	250	137,5	246	215	190	130	14	25	50,6
MXV 40-808/C	3	4	M100 V1	G1 1/2	225	40	280	80	541	311	852	250	137,5	246	215	190	130	14	26	51,6
MXV 40-810/D	4	5,5	M112 V1	G1 1/2	225	40	280	80	601	311	912	250	137,5	246	215	190	130	14	28	55,8
MXV 40-811/D	4	5,5	M112 V1	G1 1/2	225	40	280	80	631	311	942	250	137,5	246	215	190	130	14	29	56,8
MXV 40-813/C	5,5	7,5	M132 V1	G1 1/2	225	40	280	80	711	339	1050	300	159,5	246	215	190	130	14	35	77,3
MXV 40-815/C	5,5	7,5	M132 V1	G1 1/2	225	40	280	80	771	339	1110	300	159,5	246	215	190	130	14	36	78,3
MXV 40-817/C	7,5	10	M132 V1	G1 1/2	225	40	280	80	831	339	1170	300	159,5	246	215	190	130	14	38	85,7
MXV 40-819/C	7,5	10	M132 V1	G1 1/2	225	40	280	80	891	339	1230	300	159,5	246	215	190	130	14	39	86,7

(3) Standard position of terminal box. (for other positions rotate motor through 90° or 180°) (4) MXV (F) = MXV (G) + 1kg (5) With standard motor (6) Net weight

Dimensions and weights

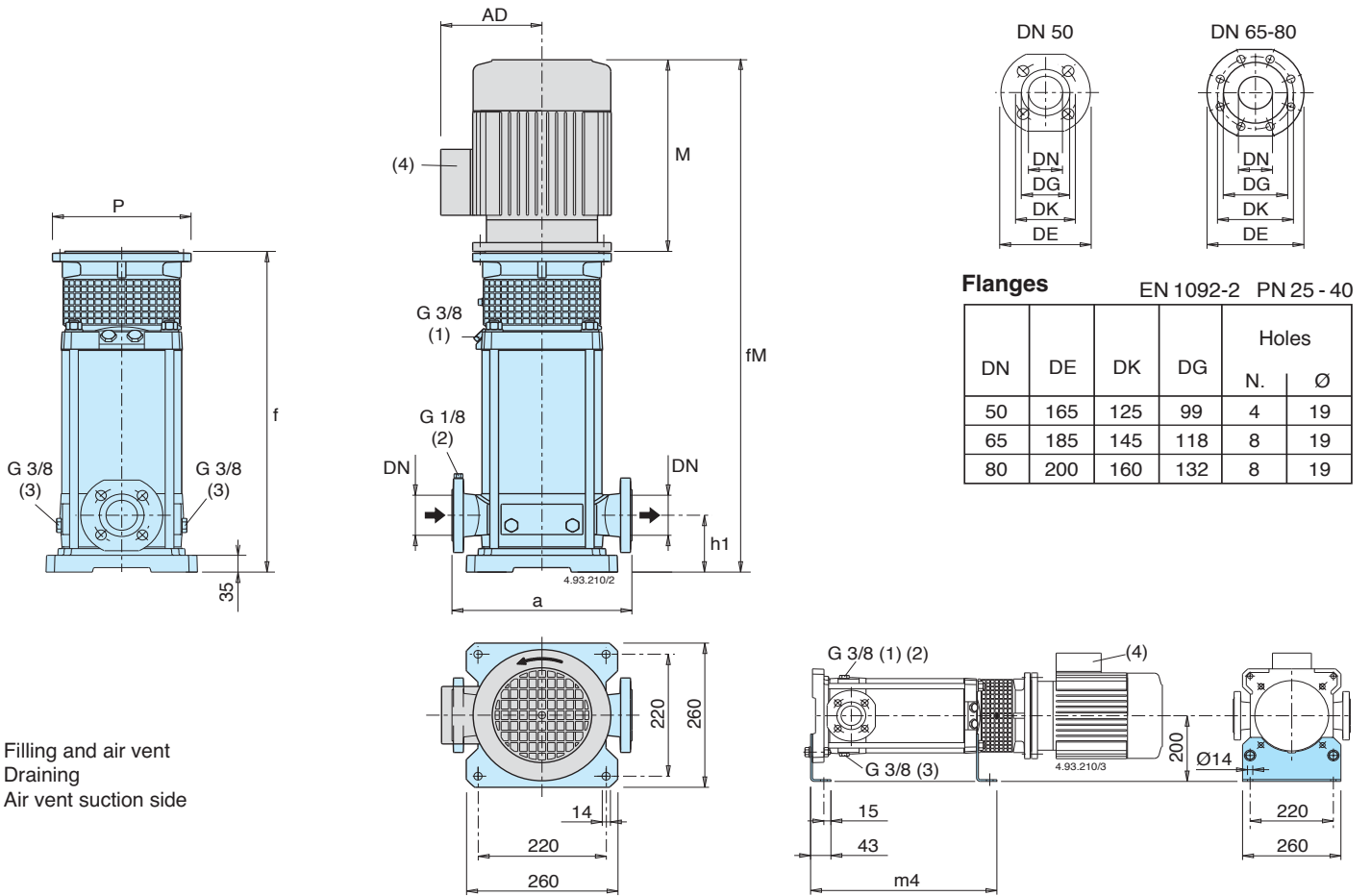

- (1) Filling and air vent
- (3) Draining
- (2) Air vent suction side

Pump	Motor			mm									without motor	with motor
	kW	HP		DN	a	h1	f	(6) M	fM	P	(6) AD	m4	MXV (5) kg (7)	(6) kg (7)
MXV 50-1603/C	3	4	M100 V1	50	300	90	395	311	706	250	137,5	322	42	67,6
MXV 50-1604/D	4	5,5	M112 V1	50	300	90	430	311	741	250	137,5	357	43	70,8
MXV 50-1605/C	5,5	7,5	M132 V1	50	300	90	484	339	823	300	159,5	391	49	91,3
MXV 50-1606/C	5,5	7,5	M132 V1	50	300	90	519	339	858	300	159,5	426	51	93,3
MXV 50-1607/C	7,5	10	M132 V1	50	300	90	553	339	892	300	159,5	460	52	99,7
MXV 50-1608/C	7,5	10	M132 V1	50	300	90	588	339	927	300	159,5	495	53	100,7
MXV 50-1609/D	11	15	M160 V1	50	300	90	652	459	1111	350	186	529	62	138
MXV 50-1610/D	11	15	M160 V1	50	300	90	687	459	1146	350	186	564	64	140
MXV 50-1611/D	11	15	M160 V1	50	300	90	721	459	1180	350	186	598	65	141
MXV 50-1612/D	15	20	M160 V1	50	300	90	756	484	1240	350	186	633	67	169
MXV 50-1614/D	15	20	M160 V1	50	300	90	825	484	1309	350	186	702	70	172
MXV 50-1616/D	18,5	25	M160 V1	50	300	90	894	484	1378	350	186	771	73	179,5
MXV 65-3202/D	4	5,5	M112 V1	65	320	105	407	311	718	250	137,5	334	45	72,8
MXV 65-3203/C	5,5	7,5	M132 V1	65	320	105	473	339	812	300	159,5	380	51	93,3
MXV 65-3204/C	7,5	10	M132 V1	65	320	105	519	339	858	300	159,5	426	53	100,7
MXV 65-3205/D	11	15	M160 V1	65	320	105	595	459	1054	350	186	472	62	138
MXV 65-3206/D	11	15	M160 V1	65	320	105	641	459	1100	350	186	518	64	140
MXV 65-3207/D	15	20	M160 V1	65	320	105	687	484	1171	350	186	564	66	168
MXV 65-3208/D	15	20	M160 V1	65	320	105	733	484	1217	350	186	610	68	170
MXV 65-3209/D	18,5	25	M160 V1	65	320	105	779	484	1236	350	186	656	70	176,5
MXV 65-3210/D	18,5	25	M160 V1	65	320	105	825	484	1309	350	186	702	72	178,5
MXV 65-3212/D	22	30	M180 V1	65	320	105	917	538	1455	350	206	794	75	204
MXV 80-4801/D	4	5,5	M112 V1	80	320	105	411	311	722	250	137,5	338	45	72,8
MXV 80-4802/C	5,5	7,5	M132 V1	80	320	105	466	339	805	300	159,5	373	51	93,3
MXV 80-4803/C	7,5	10	M132 V1	80	320	105	527	339	866	300	159,5	434	54	101,7
MXV 80-4804/D	11	15	M160 V1	80	320	105	618	459	1077	350	186	495	64	140
MXV 80-4805/D	15	20	M160 V1	80	320	105	680	484	1164	350	186	557	66	168
MXV 80-4806/D	15	20	M160 V1	80	320	105	741	484	1225	350	186	618	69	171
MXV 80-4807/D	18,5	25	M160 V1	80	320	105	802	484	1286	350	186	679	72	178,5
MXV 80-4808/D	22	30	M180 V1	80	320	105	864	538	1402	350	206	741	74	203

(4) Standard position of terminal box. (for other positions rotate motor through 90° or 180°) (5) MXV (L) : + 3 kg
MXV (H) : + 3 kg (6) With standard motor (7) Net weight

Dimensioni e pesi

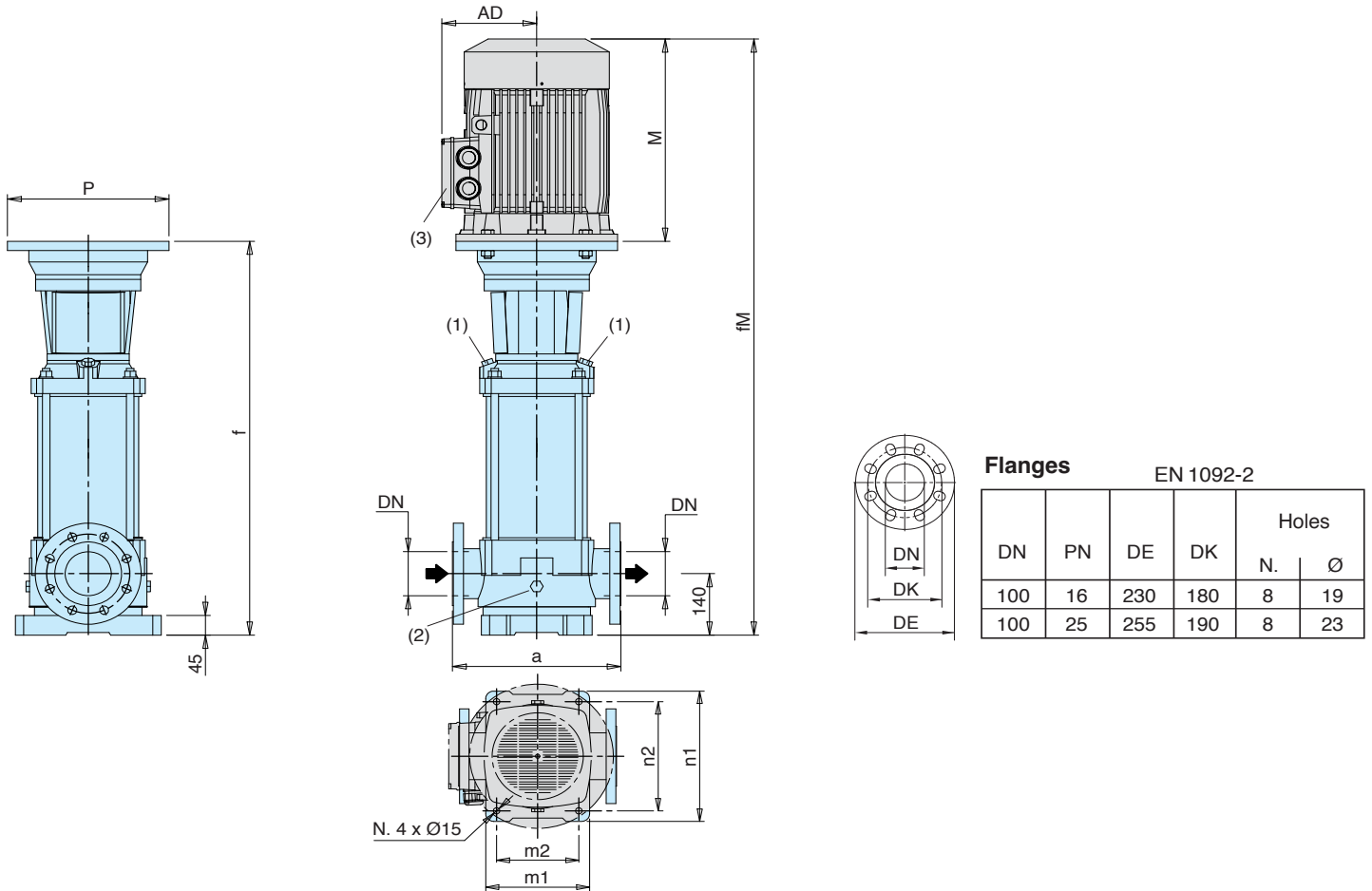

Pump	Motor				mm										without motor	with motor
	kW	HP	PN	Size	a	f	n1	n2	m1	m2	(4) M	fm	P	AD	MXV kg (5)	(4) kg (5)
MXV 100-6501	5,5	7,5	16	M132 V1	365	737	316	265	240	190	339	1076	300	159,5	81	123,3
MXV 100-6502-2R	7,5	10	16	M132 V1	365	829	316	265	240	190	339	1168	300	159,5	85,5	127,8
MXV 100-6502	11	15	16	M160 V1	365	849	316	265	240	190	459	1308	350	186	88,5	164,5
MXV 100-6503-2R	15	20	16	M160 V1	365	941	316	265	240	190	484	1425	350	186	93	195
MXV 100-6503	18,5	25	16	M160 V1	365	941	316	265	240	190	484	1425	350	186	93	199,5
MXV 100-6504-2R	18,5	25	16	M160 V1	365	1033	316	265	240	190	484	1517	350	186	97,5	204
MXV 100-6504	22	30	16	M180 V1	365	1033	316	265	240	190	538	1571	350	206	98	227
MXV 100-6505-2R	30	40	16	M200 V1	365	1131	316	265	240	190	611	1742	400	315	105,5	330,5
MXV 100-6505	30	40	16	M200 V1	365	1131	316	265	240	190	611	1742	400	315	105,5	330,5
MXV 100-6506-2R	30	40	16	M200 V1	365	1223	316	265	240	190	611	1834	400	315	110	335
MXV 100-6506	37	50	25	M200 V1	365	1223	316	265	240	190	611	1834	400	315	110	360
MXV 100-6507-2R	37	50	25	M200 V1	365	1315	316	265	240	190	611	1926	400	315	114,5	364,5
MXV 100-6507	45	60	25	M225 V1	365	1315	316	265	240	190	708	2023	450	338	117,5	432,5
MXV 100-6508-2R	45	60	25	M225 V1	365	1407	316	265	240	190	708	2115	450	338	122	437
MXV 100-6508	45	60	25	M225 V1	365	1407	316	265	240	190	708	2115	450	338	122	437
MXV 100-9001-1R	5,5	7,5	16	M132 V1	380	737	341	280	260	199	339	1076	300	159,5	82,5	124,8
MXV 100-9001	7,5	10	16	M132 V1	380	737	341	280	260	199	339	1076	300	159,5	82,5	124,8
MXV 100-9002-2R	11	15	16	M160 V1	380	849	341	280	260	199	459	1308	350	186	89	165
MXV 100-9002	15	20	16	M160 V1	380	849	341	280	260	199	484	1333	350	186	89	191
MXV 100-9003-2R	18,5	25	16	M160 V1	380	941	341	280	260	199	484	1425	350	186	93	199,5
MXV 100-9003	22	30	16	M180 V1	380	941	341	280	260	199	538	1479	350	206	93	222
MXV 100-9004-2R	30	40	16	M200 V1	380	1038	341	280	260	199	611	1649	400	315	100	325
MXV 100-9004	30	40	16	M200 V1	380	1038	341	280	260	199	611	1649	400	315	100	325
MXV 100-9005-2R	37	50	16	M200 V1	380	1131	341	280	260	199	611	1742	400	315	104	354
MXV 100-9005	37	50	16	M200 V1	380	1131	341	280	260	199	611	1742	400	315	104	354
MXV 100-9006-2R	45	60	25	M225 V1	380	1223	341	280	260	199	708	1931	450	338	110,5	425,5
MXV 100-9006	45	60	25	M225 V1	380	1223	341	280	260	199	708	1931	450	338	110,5	425,5

(4) Standard position of terminal box. (for other positions rotate motor through 90° or 180°) (5) MXV (L) : + 3 kg

(6) With standard motor

(7) Net weight

Dimensions and weights

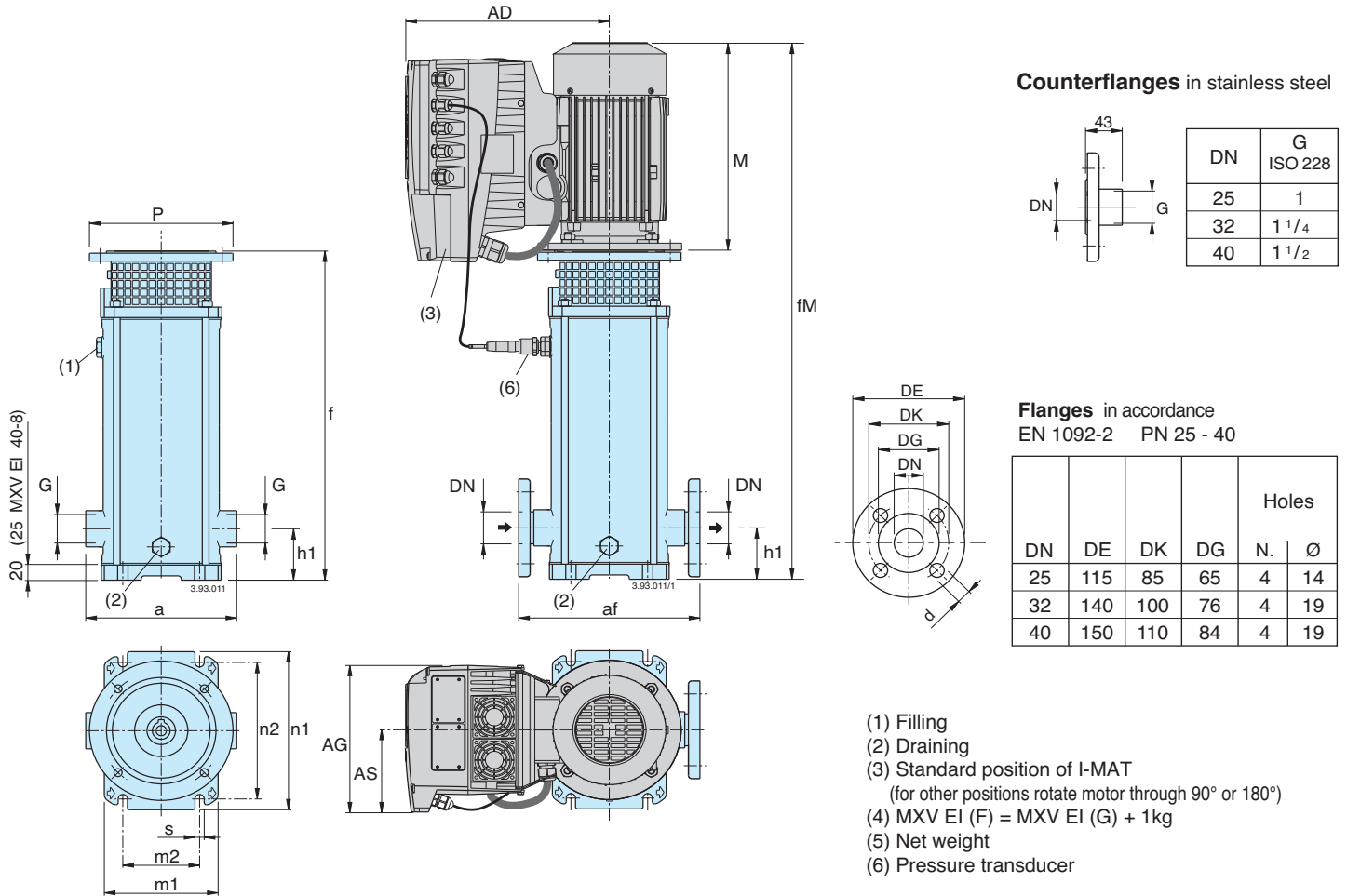

Pump	Motor		MXV EI (G) threaded ports	MXV EI (F) flanged ports	mm															MXV EI (G) (4)	
	kW	HP			G ISO 228	a	DN	af	h1	f	M	fM	P	AD	AG	AS	n1	n2	m1		m2
MXV EI 25-204/C	0,75	1	M80 V1	G1	215	25	250	75	372	255	627	200	286	190	105	210	180	150	100	12,5	36,6
MXV EI 25-205/C	0,75	1	M80 V1	G1	215	25	250	75	396	255	651	200	286	190	105	210	180	150	100	12,5	37,6
MXV EI 25-206/D	1,1	1,5	M80 V1	G1	215	25	250	75	420	255	675	200	286	190	105	210	180	150	100	12,5	39,7
MXV EI 25-207/D	1,1	1,5	M80 V1	G1	215	25	250	75	444	255	699	200	286	190	105	210	180	150	100	12,5	40,7
MXV EI 25-208/D	1,5	2	M90 V1	G1	215	25	250	75	478	255	733	200	286	190	105	210	180	150	100	12,5	43,8
MXV EI 25-210/D	1,5	2	M90 V1	G1	215	25	250	75	526	255	781	200	286	190	105	210	180	150	100	12,5	44,8
MXV EI 25-212/D	2,2	3	M90 V1	G1	215	25	250	75	574	295	869	200	286	210	118	210	180	150	100	12,5	50,6
MXV EI 25-214/D	2,2	3	M90 V1	G1	215	25	250	75	622	295	917	200	286	210	118	210	180	150	100	12,5	51,6
MXV EI 25-216/C	3	4	M100 V1	G1	215	25	250	75	680	311	991	250	294	210	118	210	180	150	100	12,5	62,1
MXV EI 25-218/C	3	4	M100 V1	G1	215	25	250	75	728	311	1039	250	294	210	118	210	180	150	100	12,5	64,1
MXV EI 25-220/C	3	4	M100 V1	G1	215	25	250	75	776	311	1087	250	294	210	118	210	180	150	100	12,5	65,1
MXV EI 32-404/D	1,1	1,5	M80 V1	G 1 1/4	215	32	250	75	372	255	627	200	286	190	105	210	180	150	100	12,5	37,6
MXV EI 32-405/D	1,1	1,5	M80 V1	G 1 1/4	215	32	250	75	396	255	651	200	286	190	105	210	180	150	100	12,5	38,6
MXV EI 32-406/D	1,5	2	M90 V1	G 1 1/4	215	32	250	75	430	255	685	200	286	190	105	210	180	150	100	12,5	42,8
MXV EI 32-407/D	1,5	2	M90 V1	G 1 1/4	215	32	250	75	454	255	709	200	286	190	105	210	180	150	100	12,5	43,8
MXV EI 32-408/D	2,2	3	M90 V1	G 1 1/4	215	32	250	75	478	295	773	200	286	210	118	210	180	150	100	12,5	48,6
MXV EI 32-410/D	2,2	3	M90 V1	G 1 1/4	215	32	250	75	526	295	821	200	286	210	118	210	180	150	100	12,5	49,6
MXV EI 32-412/C	3	4	M100 V1	G 1 1/4	215	32	250	75	584	311	895	250	294	210	118	210	180	150	100	12,5	60,1
MXV EI 32-414/C	3	4	M100 V1	G 1 1/4	215	32	250	75	632	311	943	250	294	210	118	210	180	150	100	12,5	62,1
MXV EI 32-416/D	4	5,5	M112 V1	G 1 1/4	215	32	250	75	680	311	991	250	294	210	118	210	180	150	100	12,5	65,8
MXV EI 32-418/D	4	5,5	M112 V1	G 1 1/4	215	32	250	75	728	311	1039	250	294	210	118	210	180	150	100	12,5	66,8
MXV EI 40-804/D	1,5	2	M90 V1	G 1 1/2	225	40	280	80	411	255	666	200	286	190	105	246	215	190	130	14	42,8
MXV EI 40-805/D	2,2	3	M90 V1	G 1 1/2	225	40	280	80	441	295	736	200	286	210	118	246	215	190	130	14	47,6
MXV EI 40-806/D	2,2	3	M90 V1	G 1 1/2	225	40	280	80	471	295	766	200	286	210	118	246	215	190	130	14	48,6
MXV EI 40-807/C	3	4	M100 V1	G 1 1/2	225	40	280	80	511	311	822	250	294	210	118	246	215	190	130	14	58,6
MXV EI 40-808/C	3	4	M100 V1	G 1 1/2	225	40	280	80	541	311	852	250	294	210	118	246	215	190	130	14	59,6
MXV EI 40-810/D	4	5,5	M112 V1	G 1 1/2	225	40	280	80	601	311	912	250	294	210	118	246	215	190	130	14	63,8
MXV EI 40-811/D	4	5,5	M112 V1	G 1 1/2	225	40	280	80	631	311	942	250	294	210	118	246	215	190	130	14	64,8
MXV EI 40-813/C	5,5	7,5	M132 V1	G 1 1/2	225	40	280	80	711	339	1050	300	321	210	118	246	215	190	130	14	85,3
MXV EI 40-815/C	5,5	7,5	M132 V1	G 1 1/2	225	40	280	80	771	339	1110	300	321	210	118	246	215	190	130	14	86,3
MXV EI 40-817/C	7,5	10	M132 V1	G 1 1/2	225	40	280	80	831	339	1170	300	368	281	153	246	215	190	130	14	100,5
MXV EI 40-819/C	7,5	10	M132 V1	G 1 1/2	225	40	280	80	891	339	1230	300	368	281	153	246	215	190	130	14	101,5

Dimensions and weights

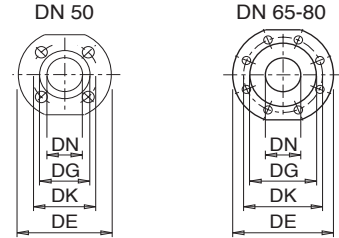
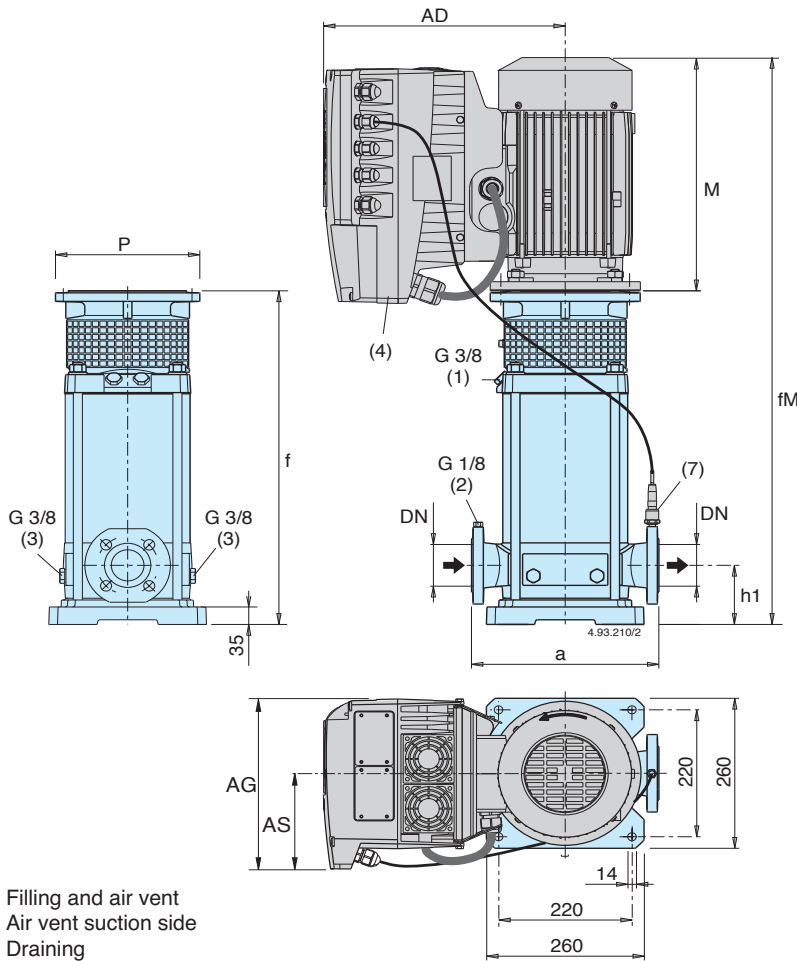

Flanges in accordance
EN 1092-2 PN 25 - 40

DN	DE	DK	DG	Holes	
				N.	Ø
50	165	125	99	4	19
65	185	145	118	8	19
80	200	160	132	8	19

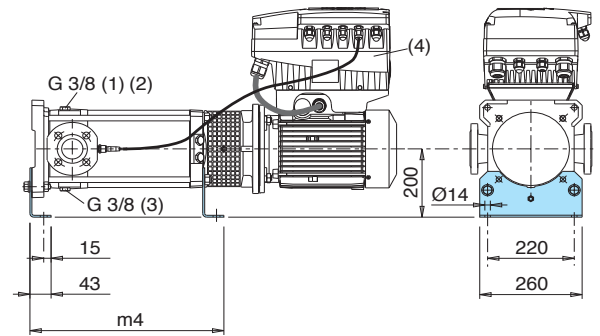

- (1) Filling and air vent
- (2) Air vent suction side
- (3) Draining
- (4) Standard position of I-MAT
(for other positions rotate motor through 90° or 180°)

- (5) MXV (L) : + 3 kg, MXV (H) : + 3 kg
- (6) Net weight (7) Pressure transducer

Pump	Motor			mm											MXV EI (5) kg (6)
	kW	HP		DN	a	h1	f	M	fM	P	AD	AG	AS	m4	
MXV EI 50-1603/C	3	4	M100 V1	50	300	90	395	311	706	250	294	210	118	322	75,1
MXV EI 50-1604/D	4	5,5	M112 V1	50	300	90	430	311	741	250	294	210	118	357	78,8
MXV EI 50-1605/C	5,5	7,5	M132 V1	50	300	90	484	339	823	300	321	210	118	391	99,3
MXV EI 50-1606/C	5,5	7,5	M132 V1	50	300	90	519	339	858	300	321	210	118	426	101,3
MXV EI 50-1607/C	7,5	10	M132 V1	50	300	90	553	339	892	300	368	281	153	460	114,5
MXV EI 50-1608/C	7,5	10	M132 V1	50	300	90	588	339	927	300	368	281	153	495	115,5
MXV EI 50-1609/D	11	15	M160 V1	50	300	90	652	459	1111	350	393	281	153	529	152,8
MXV EI 50-1610/D	11	15	M160 V1	50	300	90	687	459	1146	350	393	281	153	564	154,8
MXV EI 50-1611/D	11	15	M160 V1	50	300	90	721	459	1180	350	393	281	153	598	155,8
MXV EI 50-1612/D	15	20	M160 V1	50	300	90	756	484	1240	350	471	350	190	633	204
MXV EI 50-1614/D	15	20	M160 V1	50	300	90	825	484	1309	350	471	350	190	702	207
MXV EI 50-1616/D	18,5	25	M160 V1	50	300	90	894	484	1378	350	471	350	190	771	215
MXV EI 65-3202/D	4	5,5	M112 V1	65	320	105	407	311	718	250	294	210	118	334	80,8
MXV EI 65-3203/C	5,5	7,5	M132 V1	65	320	105	473	339	812	300	321	210	118	380	101,3
MXV EI 65-3204/C	7,5	10	M132 V1	65	320	105	519	339	858	300	368	281	153	426	115,5
MXV EI 65-3205/D	11	15	M160 V1	65	320	105	595	459	1054	350	393	281	153	472	152,8
MXV EI 65-3206/D	11	15	M160 V1	65	320	105	641	459	1100	350	393	281	153	518	154,8
MXV EI 65-3207/D	15	20	M160 V1	65	320	105	687	484	1171	350	471	350	190	564	203
MXV EI 65-3208/D	15	20	M160 V1	65	320	105	733	484	1217	350	471	350	190	610	205
MXV EI 65-3209/D	18,5	25	M160 V1	65	320	105	779	484	1236	350	471	350	190	656	212
MXV EI 65-3210/D	18,5	25	M160 V1	65	320	105	825	484	1309	350	471	350	190	702	214
MXV EI 65-3212/D	22	30	M180 V1	65	320	105	917	538	1455	350	491	350	190	794	239
MXV EI 80-4801/D	4	5,5	M112 V1	80	320	105	411	311	722	250	294	210	118	338	80,8
MXV EI 80-4802/C	5,5	7,5	M132 V1	80	320	105	466	339	805	300	321	210	118	373	101,3
MXV EI 80-4803/C	7,5	10	M132 V1	80	320	105	527	339	866	300	368	281	153	434	116,5
MXV EI 80-4804/D	11	15	M160 V1	80	320	105	618	459	1077	350	393	281	153	495	154,8
MXV EI 80-4805/D	15	20	M160 V1	80	320	105	680	484	1164	350	471	350	190	557	203
MXV EI 80-4806/D	15	20	M160 V1	80	320	105	741	484	1225	350	471	350	190	618	206
MXV EI 80-4807/D	18,5	25	M160 V1	80	320	105	802	484	1286	350	471	350	190	679	214
MXV EI 80-4808/D	22	30	M180 V1	80	320	105	864	538	1402	350	491	350	190	741	238

Dimensions and weights

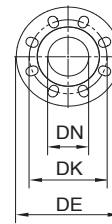
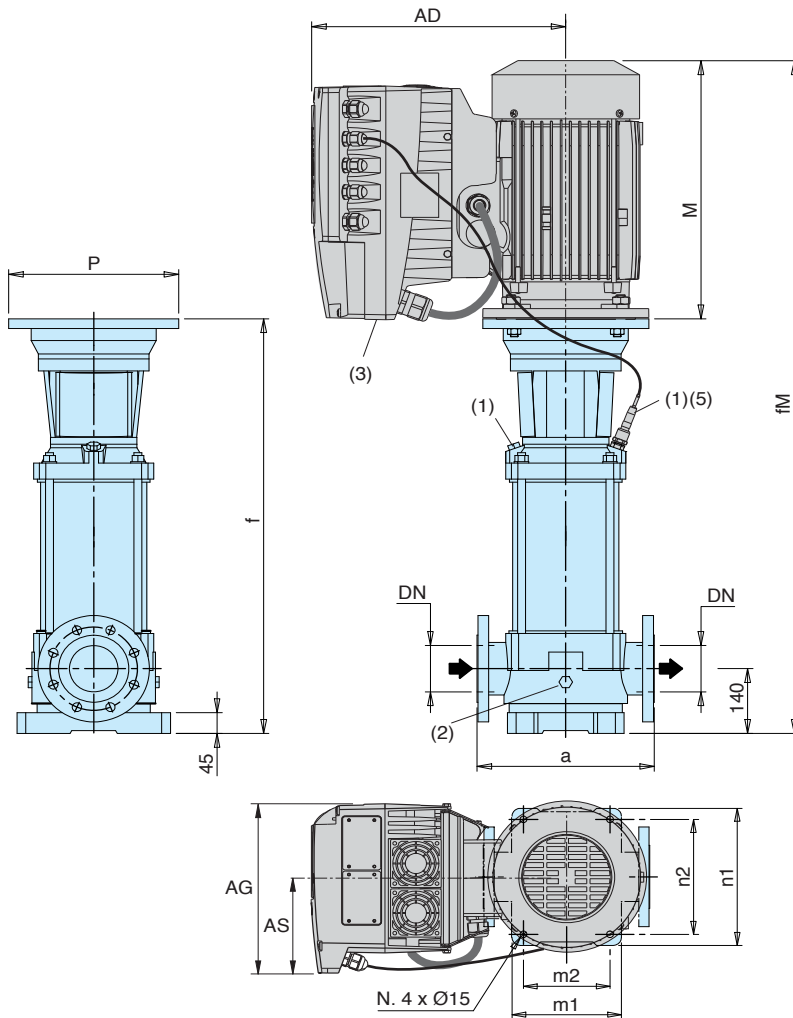

Flanges in accordance EN 1092-2

DN	PN	DE	DK	Holes	
				N.	Ø
100	16	230	180	8	19
100	25	225	190	8	23

- (1) Filling and air vent
- (2) Draining
- (3) Standard position of I-MAT
(for other positions rotate motor through 90° or 180°)
- (4) Net weight
- (5) Pressure transducer

Pump	Motor				mm												MXV EI kg (4)
	kW	HP	PN	Size	a	f	n1	n2	m1	m2	M	fm	P	AD	AG	AS	
MXV EI 100-6501	5,5	7,5	16	M132 V1	365	737	316	265	240	190	339	1076	300	321	210	118	131,3
MXV EI 100-6502-2R	7,5	10	16	M132 V1	365	829	316	265	240	190	339	1168	300	368	281	153	142,6
MXV EI 100-6502	11	15	16	M160 V1	365	849	316	265	240	190	459	1308	350	393	281	153	179,3
MXV EI 100-6503-2R	15	20	16	M160 V1	365	941	316	265	240	190	484	1425	350	471	350	190	230
MXV EI 100-6503	18,5	25	16	M160 V1	365	941	316	265	240	190	484	1425	350	471	350	190	235
MXV EI 100-6504-2R	18,5	25	16	M160 V1	365	1033	316	265	240	190	484	1517	350	471	350	190	239
MXV EI 100-6504	22	30	16	M180 V1	365	1033	316	265	240	190	538	1571	350	491	350	190	262
MXV EI 100-9001-1R	5,5	7,5	16	M132 V1	380	737	341	280	260	199	339	1076	300	321	210	118	132,8
MXV EI 100-9001	7,5	10	16	M132 V1	380	737	341	280	260	199	339	1076	300	368	281	153	139,6
MXV EI 100-9002-2R	11	15	16	M160 V1	380	849	341	280	260	199	459	1308	350	393	281	153	179,8
MXV EI 100-9002	15	20	16	M160 V1	380	849	341	280	260	199	484	1333	350	471	350	190	226
MXV EI 100-9003-2R	18,5	25	16	M160 V1	380	941	341	280	260	199	484	1425	350	471	350	190	235
MXV EI 100-9003	22	30	16	M180 V1	380	941	341	280	260	199	538	1479	350	491	350	190	257

Features

Long Service Life with Standard Motor

Pump with thrust bearing without additional axial loads on the motor bearings.

Any standard motor V1 design (suitable to be lifted in vertical position) can be used, of our choice or of Client's choice.

Easy Assembly of the Motor

With the single-piece sleeve coupling the pump unit can be supplied fully assembled also without the motor. This eliminates the risk of damage caused by shifting of the pump shaft during transportation. The motor is simply inserted in the coupling and fastened to the flange without the necessity for adapting the axial position of the pump shaft.

Extra Safety

Single-piece coupling guard to be removed only by means of a tool, positioned around the lantern bracket, thus avoiding accidental pushing and rubbing against the coupling.

Low Cost Installation

Vertical construction with reduced pump height for installation in small spaces.

In-line connections to simplify the piping layout with the possibility of inserting the pump in straight pipe-lines.

Disassembly, inspection or cleaning of internal parts without removal of piping.

Robust and Reliable

Single PN 25 construction for all pump sizes.

The suction and discharge nozzles arranged in-line absorb the forces of the piping on the pump without the creation of distorting loads causing local friction and early wears.

The lantern brackets compact and robust design maintains a sure alignment between rotating and fixed parts, reducing vibration.

The upper cover design prevents entrapment of air around the mechanical seal.

Low-Noise Operation

The water filled shroud around the stages and thick external walls, work together for low-noise operation.

Low-noise standard motor.

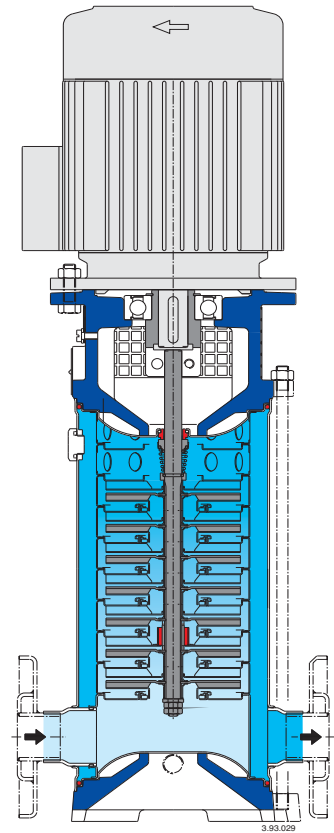

MXV 25-2, 32-4, 40-8

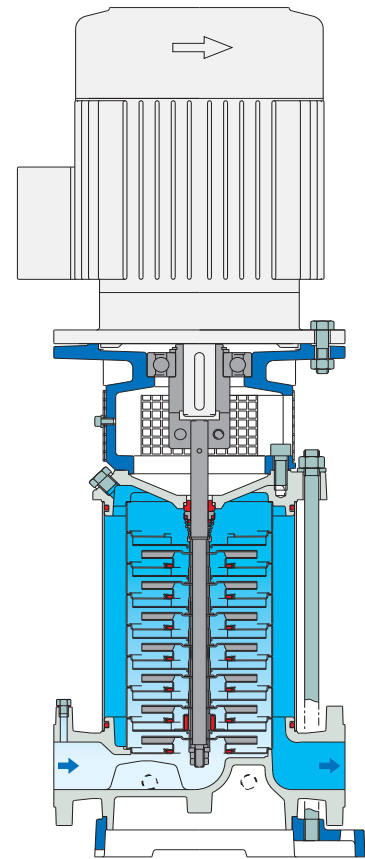

MXV 50-16, 65-32, 80-48



Construction

Vertical multi-stage pumps with suction and delivery connections of the same diameter and arranged along the same axis (in-line). Corrosion-resistant bearing sleeves lubricated by the pumped liquid. A pump with thrust bearing and sleeve coupling for use of any standard motor with IM V1 construction.

Version with frequency converter (on request)

Applications

For water supply systems.
For clean non-explosive liquids, without solid, filamentary or abrasive matter (with adaptation of sealing materials on request).
A universal pump for civil and industrial use, for pressure-boosting systems, fire-extinguishing systems, high-pressure washing plants, irrigation, agricultural uses and sport installations.

Operating conditions

Temperature of liquid: from -15 °C to +110 °C.
Operating environment temperature: up to 40 °C.
Maximum permissible pressure in pump casing: 25 bar.

Motor

Standard-type: 2-pole induction motor, 50 Hz (n ≈ 2900 rpm).
Construction IM V1 (EN 60034-7).
Motor suitable for operation with frequency converter.
Classification scheme IE3 for three-phase motors.
Insulation class F.
Protection IP 55.
three-phase with rated voltage: up to 3 kW 230/400 V;
from 4 kW 400/690 V.

The electropumps MXVL series comply with the European Regulation no. 547/2012.

MXVL 25, 32, 40

All parts that come into contact with the liquid, including wet-end covers, are in chrome-nickel-molybdenum stainless steel AISI 316L.

Materials (wetted parts)

Component	Material
Flange	Stainless Steel 1.4404 EN 10088 (AISI 316L)
External jacket	
Suction casing	
Delivery casing	
Stage casing	
Impeller	
Lower cover	
Upper cover	
Spacer sleeve	
Pump shaft	Stainless Steel 1.4404 EN 10088 (AISI 316L)
Plug	
Bearing sleeve	Corrosion-resistant, cemented carbide Ceramic alumina
Bearing in stage casing	
Mechanical seal ISO 3069 - KU	Hard metal/Carbon/EPDM.
Wear ring	PTFE
O-rings	NBR

Direction of rotation: clockwise as seen from the motor.

Variants (to be specified when ordering)

- Pump with threaded ports (G).
- Pump with flanged ports (F).
- Pump without motor.
- Pump with standard motor.

Other variants (on request)

- With counter-flanges in chrome-nickel steel.
- O-rings FPM. Other mechanical seal.
- Pump with motor of Client's choice (if available).
- Single-phase motor 230 V, up to 2.2 kW.
- 4-pole induction motor (MXVL4 series).
- Other voltage ratings.
- Frequency 60 Hz.

MXVL 50, 65, 80, 100

Internal parts in contact with the liquid with pump casing and upper cover in chrome-nickel-molybdenum stainless steel AISI 316L.

Materials (wetted parts)

Component	Material
Pump casing	Stainless Steel 1.4404 EN 10088 (AISI 316L)
Upper cover	
External jacket	Stainless Steel 1.4404 EN 10088 (AISI 316L)
Stage casing	
Impeller	
Spacer sleeve	
Pump shaft	Stainless Steel (AISI 316L)(AISI 329 for MXVL 100) Stainless Steel 1.4404 EN 10088 (AISI 316L)
Plug	
Bearing sleeve	Corrosion-resistant, cemented carbide Ceramic alumina (Corrosion-resistant, cemented carbide for MXVL 100)
Bearing in stage casing	
Mechanical seal ISO 3069 - KU	Hard metal/Carbon/EPDM
Wear ring	PTFE
O-rings	NBR (EPDM for MXV 100)

Direction of rotation: anticlockwise as seen from the motor.
(clockwise as seen from the motor for MXVL 100)

Variants (to be specified when ordering)

- Pump without motor.
- Pump with standard motor.

Other variants (on request)

- O-rings FPM. Other mechanical seal.
- Pump with motor of Client's choice (if available).
- Other voltage ratings.
- 4-pole induction motor (MXVL4 series).
- Frequency 60 Hz.
- Pump with support feet for horizontal installation (H1 or H2).
- Support feet for horizontal installation, set.
- Welding counter-flanges, PN 25 (steel).

MXVL 25, 32, 40

Designation

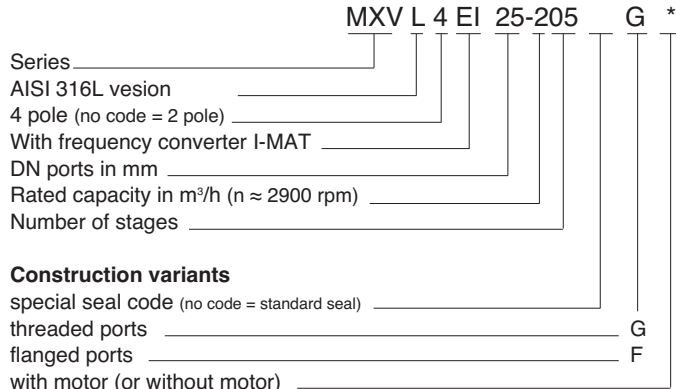

* with no further designation = with standard motor

MXVL 50, 65, 80, 100

Designation

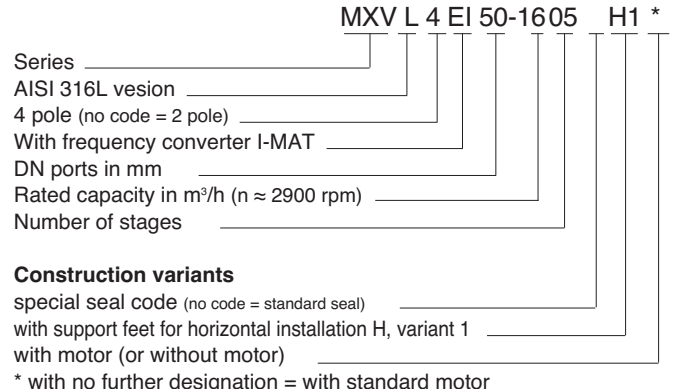

* with no further designation = with standard motor

Pipe connection

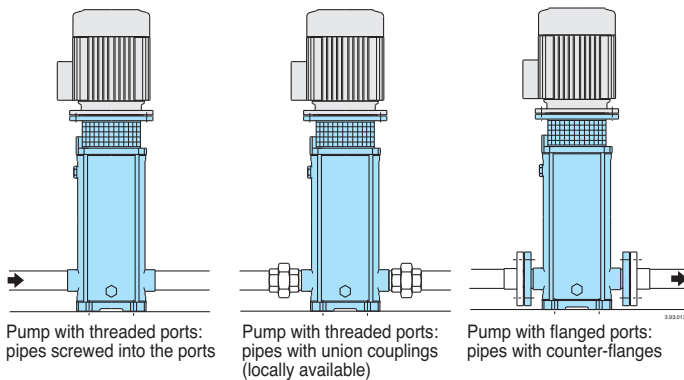

Installations

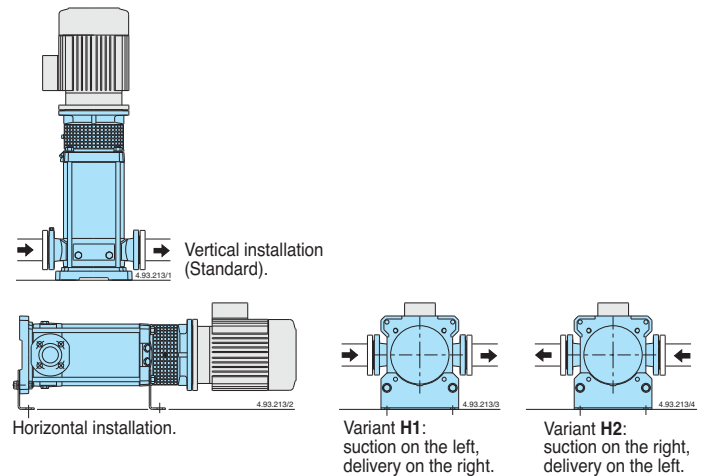

Variable parts

Pump size MXVL - MXV4L			Number of stages	Stage casings with bearing
25 - 204	32 - 404	40 - 804		
25 - 205	32 - 405	40 - 805	5	1
25 - 206	32 - 406	40 - 806	6	1
25 - 207	32 - 407	40 - 807	7	1
25 - 208	32 - 408	40 - 808	8	1
25 - 210	32 - 410	40 - 810	10	1
25 - 212	32 - 412	40 - 811	11	2
		40 - 813	12	2
		40 - 815	13	2
25 - 214	32 - 414	40 - 813	14	2
		40 - 815	15	2
25 - 216	32 - 416	40 - 815	16	2
25 - 218	32 - 418	40 - 815	18	2
25 - 220		40 - 817	17	3
		40 - 819	19	3
		40 - 819	20	3

Variable parts

Pump size MXVL - MXV4L			Number of stages	Stage casings with bearing
50 - 1603 50 - 1604 50 - 1605 50 - 1606 50 - 1607 50 - 1608 50 - 1609 50 - 1610	65 - 3202 65 - 3203 65 - 3204 65 - 3205 65 - 3206 65 - 3207	80 - 4801		
		80 - 4802	2	1
		80 - 4803	3	1
		80 - 4804	4	1
		80 - 4805	5	1
			6	1
			7	1
			8	1
			9	1
			10	1
50 - 1611 50 - 1612 50 - 1614 50 - 1616	65 - 3208 65 - 3209 65 - 3210 65 - 3212	80 - 4806	6	2
		80 - 4807	7	2
		80 - 4808	8	2
			9	2
			10	2
			11	2
			12	2
			14	2
	16	2		

Coverage chart

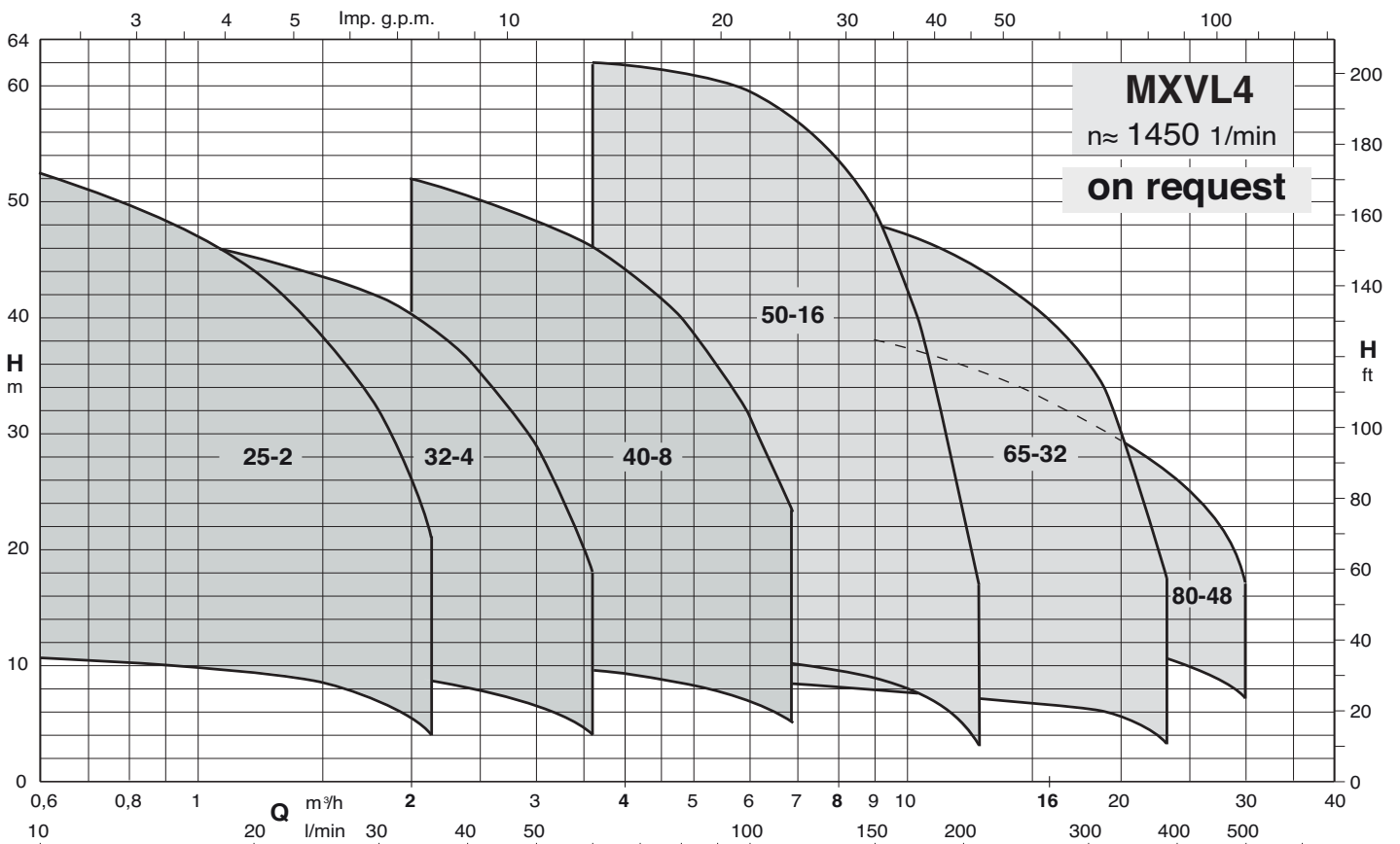
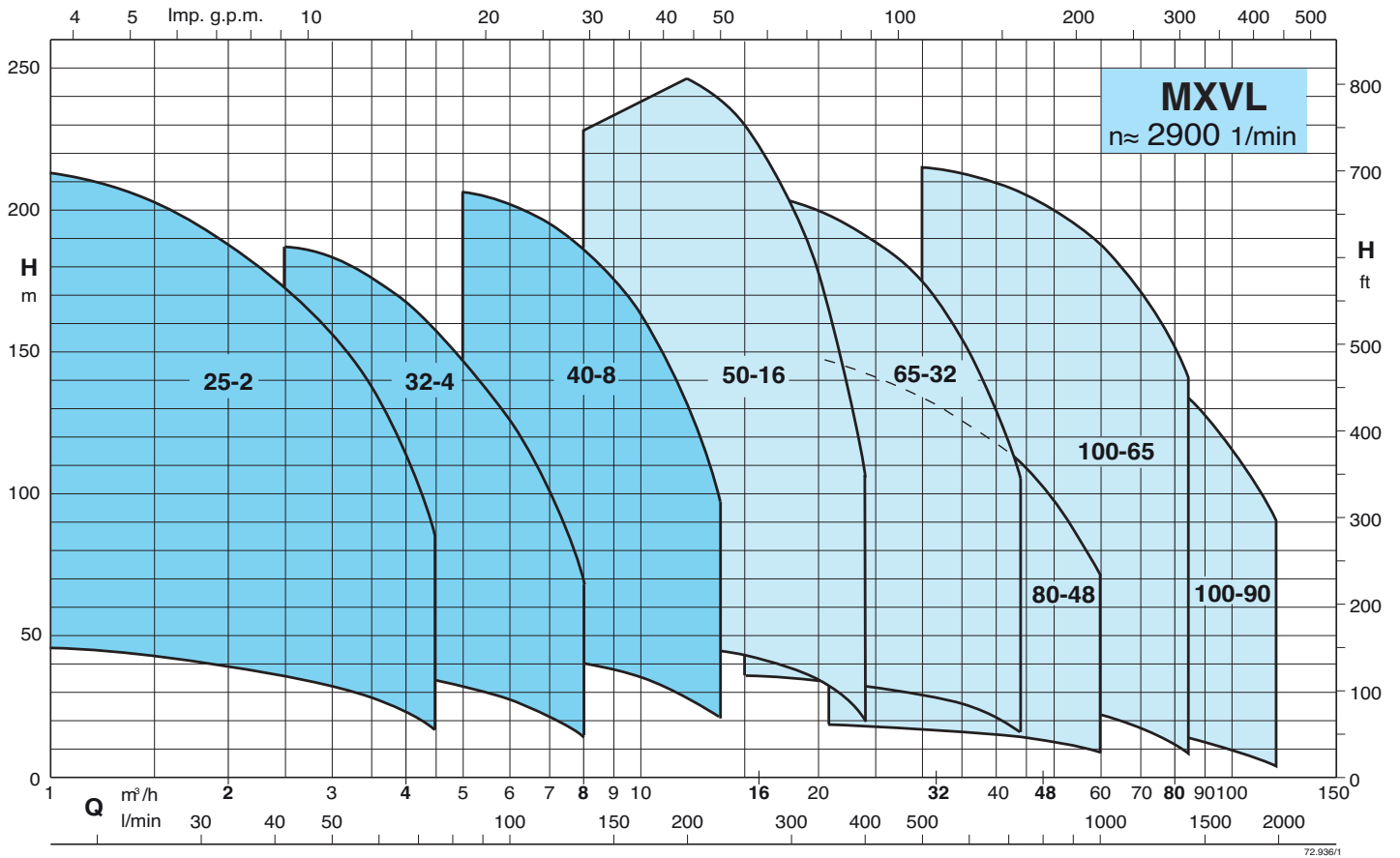

For characteristic curves, dimensions and weights see MXV