

DN SERIES

SUBMERSIBLE PUMPS FOR DIRTY WATER

Drainage pumps with up to 20 metre head and up to 280 l/min (15 m³/h) delivery.

This range consists of three pumps with up to 0.75 kW (1HP) rated power.

APPLICATIONS

- Draining of flooded excavations and marshy ground.
- Irrigation from rainwater reservoirs, ditches, ponds and watercourses.

SPECIFICATIONS

- Open **impeller** with **abrasion-resistant** rubber coating.
- Squirrel cage **motor** in a dielectric non-toxic **oil cooled**, which ensures the lubrication of the ball bearings and more efficient cooling.
- **IP 68 protection.**
- Mechanical seal protected by sand labyrinth.
- Maximum **immersion depth: 5 m.**
- **Maximum liquid temperature.**
50°C with fully submerged pump.
25°C with partially submerged pump.
- Versions:

Single-phase 220-240 V 50 Hz, with built-in automatic reset overload protection and capacitor housed in a control box on the cable.

Three-phase 220-240 or 380-415 V 50 Hz.

Overload protection to be provided by user and installed in the control box.

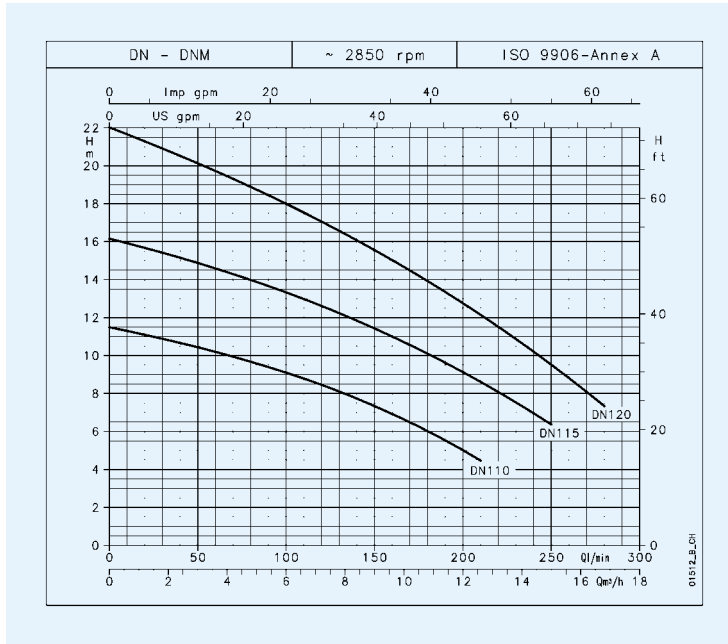

TABLE OF MATERIALS

PART	MATERIAL
Pump body	200 UNI ISO 185 CAST IRON*
Impeller	STEEL + NITRILE RUBBER
Wear flange, Suction screen, Motor casing	STAINLESS STEEL (AISI 304 - DIN 1,4301)
Mechanical seal	CARBON/CERAMIC/ NITRILE RUBBER
O-ring	NITRILE RUBBER
Shaft extension	STAINLESS STEEL (AISI 303 - DIN 1.4305)

* Cast iron, coated with polybutadiene varnish by electrophoresis at 180°C.

OPERATING CHARACTERISTICS AT 2850 rpm 50 Hz



PUMP TYPE	RATED POWER		Q = DELIVERY												
			H = TOTAL HEAD METERS COLUMN OF WATER												
			l/min	0	25	50	75	100	125	150	175	210	225	250	280
			m ³ /h	0	1.5	3	4.5	6	7.5	9	10.5	12.6	13.5	15	16.8
	kW	HP													
DN(M) 110	0.6	0.8		11.5	11.0	10.4	9.8	9.1	8.3	7.3	6.3	4.5			
DN(M) 115	0.6	0.8		16.2	15.6	14.9	14.1	13.3	12.4	11.4	10.3	8.6	7.8	6.4	
DN(M) 120	0.75	1		22.0	21.1	20.1	19.1	18.0	16.8	15.6	14.2	12.1	11.2	9.5	7.3

These performances are valid for liquids with density $\rho = 1.0 \text{ kg/dm}^3$ and kinematic viscosity $\gamma = 1 \text{ mm}^2/\text{sec}$.

dn-2p50_a_th

PUMP TYPE	INPUT POWER*	INPUT CURRENT*	CAPACITOR
SINGLE-PHASE	kW	220-240 V A	$\mu\text{F} / 450 \text{ V}$
DNM 110	0.68	3.56	25
DNM 115	0.90	4.28	25
DNM 120	1.03	4.77	25

* Maximum value in specified range

PUMP TYPE	INPUT POWER*	INPUT CURRENT*	INPUT CURRENT*
THREE-PHASE	kW	220-240 V A	380-415 V A
DN 110	0.66	-	2.00
DN 115	0.93	-	2.20
DN 120	1.09	4.05	2.34

dn-2p50_a_te

DN SERIES DIMENSIONS AND WEIGHTS

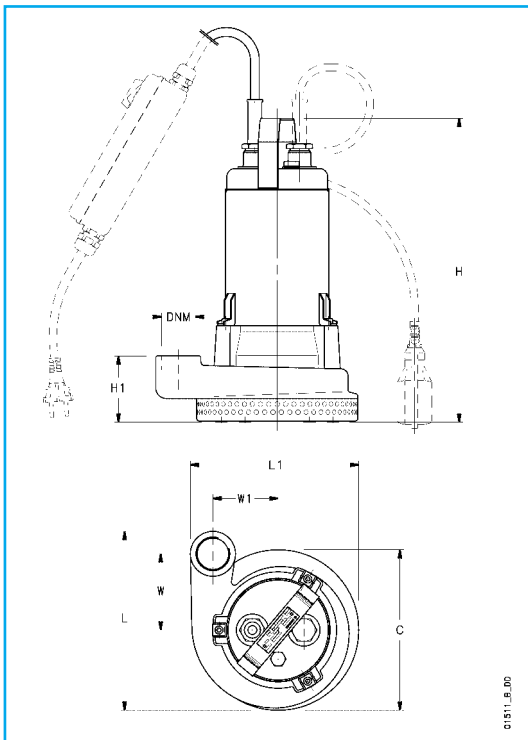

PUMP TYPE	DIMENSIONS (mm)								DNM	WEIGHT kg
	C	H	H1	L	L1	W	W1			
DNM110-DN110	Ø 200	380	81	209	223	81	95	Rp 1 1/4	18.5	
DNM115-DN115	Ø 200	380	81	209	223	81	95	Rp 1 1/4	18.5	
DNM120-DN120	Ø 200	380	81	209	223	81	95	Rp 1 1/4	19.5	

dn-2p50_a_td