

MODEL 2930 Downflow

Service Manual



IMPORTANT: Fill in pertinent information on page 2 for future reference.

MODEL 2930

Job Specification Sheet

- JOB NO. _____
- MODEL NO. _____
- WATER TEST _____
- CAPACITY PER UNIT _____ MAX. _____ PER REGENERATION
- MINERAL TANK SIZE DIA. _____ HEIGHT _____
- BRINE TANK SIZE & SALT SETTING PER REGENERATION:

2930 CONTROL VALVE SPECIFICATIONS

1) Type of Timer (see pages 20-24)

- A) 7 day or 12 day
- B) * 1,250 to 21,250 gallon meter or
* 6,250 to 106,250 gallon meter
* Other _____

C) Meter Wiring Package

- 1) System #4 - 1 tank; 1 meter; immediate or delayed regeneration
- 2) System #5 - 2 tanks; 2 meters; interlock
- 3) System #6 - 2 tanks; 1 meter; series regeneration
- 4) System #7 - 2 tanks; 1 meter; alternator

2) Timer Program Settings (see pages 23 and 24)

- A) Backwash _____ min.
- B) Brine & Slow Rinse _____ min.
- C) Rapid Rinse _____ min.
- D) Brine Tank Refill _____ min.

3) Drain Line Flow Controller _____ gpm

4) Brine Line Flow Controller _____ gpm

5) Injector Size # _____

- 6) A) Hard Water By-Pass
- B) No Hard Water By-Pass

MODEL 2930

General Commercial Pre-Installation Check List

WATER PRESSURE: A minimum of 25 pounds of water pressure is required for regeneration valve to operate effectively.

ELECTRICAL FACILITIES: A continuous 110 volt, 60 Hertz current supply is required (other voltages available). Make certain the current supply is always hot and cannot be turned off with another switch.

EXISTING PLUMBING: Condition of existing plumbing should be free from lime and iron buildup. Piping that is built up heavily with lime and/or iron should be replaced. If piping is clogged with iron, a separate iron filter unit should be installed ahead of the water softener.

LOCATION OF SOFTENER AND DRAIN: The softener should be located close to a drain.

BY-PASS VALVES: Always provide for the installation of isolation and by-pass valves.

CAUTION: Water pressure is not to exceed 120 p.s.i., water temperature is not to exceed 100° F, and the unit cannot be subjected to freezing conditions.

Installation Instructions

1. Place the softener tank where you want to install the unit making sure the unit is level and on a firm base. (Maximum 7 feet apart for twin units.)
2. All plumbing should be done in accordance with local plumbing codes. The pipe size for the drain line should be the same size or larger than the drain line flow control connection. Water meters are to be installed on soft water outlets. Twin units with (1) one meter shall be installed on common soft water outlet of units. If possible, minimize height of drain line above valve.
3. Teflon tape is the only sealant to be used on the drain fitting. The drain from twin units may be run through a common line.
4. Make sure that the floor is clean beneath the salt storage tank and that it is level.
5. Place approximately 1" of water above the grid plate (if used) in your salt tank. Salt may be placed in the unit at this time.
6. Close softener isolation valves and open the bypass valve. Turn on the main water supply. Open a cold soft water tap nearby and let run a few minutes or until the system is free from foreign material (usually solder) that may have resulted from the installation.
7. Open the softener inlet valves and close the bypass valve.
8. Manually index the softener control into "service" position and let water flow into the mineral tank. When water flow stops, open a cold water tap nearby and let run until air pressure is relieved.
9. Electrical: All electrical connections must be connected according to codes. Use electrical conduit if applicable. Remote meter systems and Twin meter system wiring diagrams are on pages 29-33.
10. Plug into power supply.

MODEL 2930

Water Conditioner Flow Diagrams

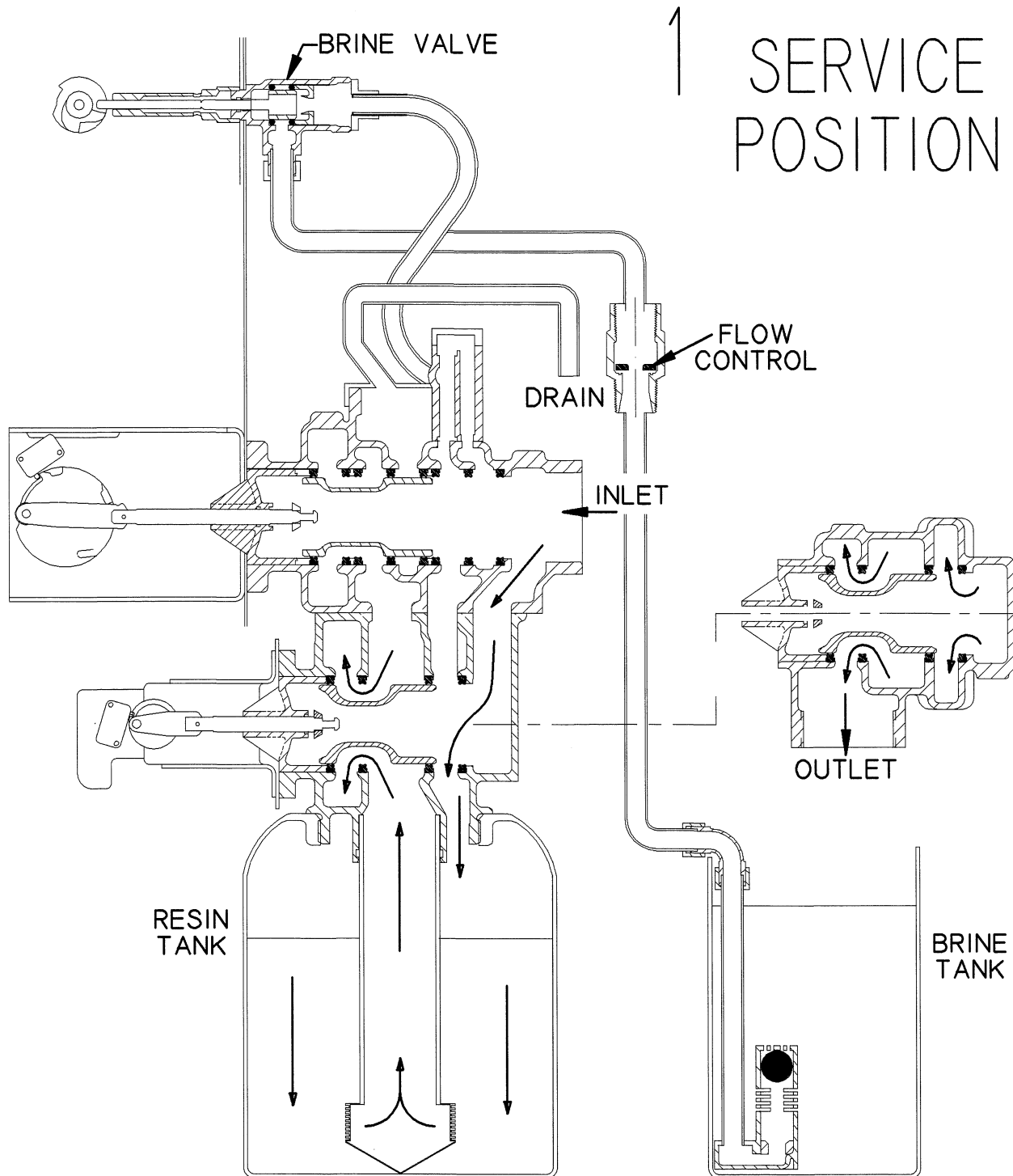

Hard water enters regeneration unit and flows down into transfer units top of tank. Hard water passes through mineral in mineral tank. Conditioned water enters center tube through bottom distributor - then flows up thru the center tube - around the piston and out the side outlet of the valve.

MODEL 2930

Water Conditioner Flow Diagrams (Cont'd.)

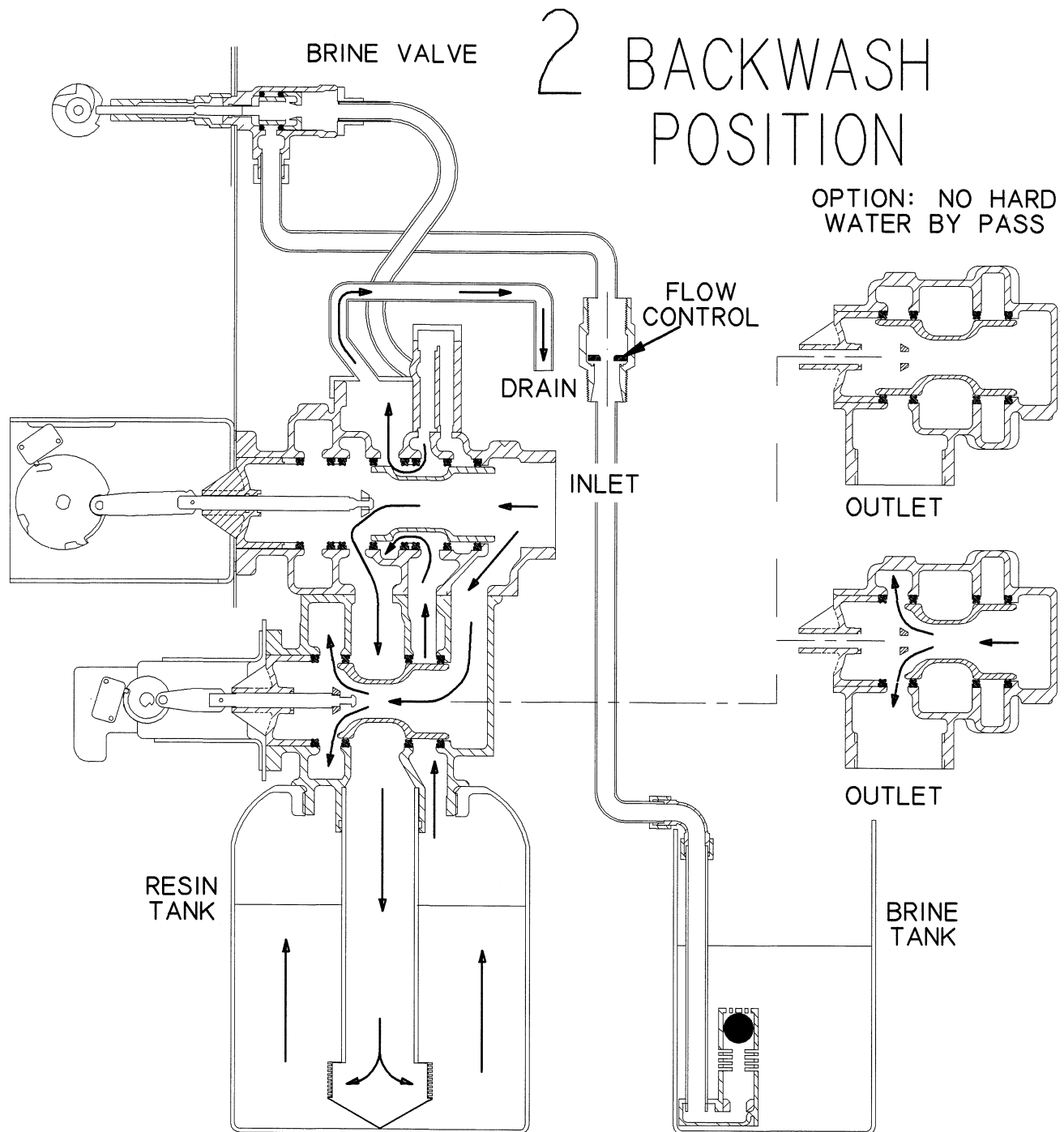

Hard water enters regeneration unit inlet - flows down thru service adapter for by pass, and thru regeneration piston - down the center tube - thru the bottom distributor and up thru the mineral - around the piston and out the drain line. If optional no hard water by pass piston is used, water flow to outlet is prevented by an extended section of the service piston which closes the outlet port from by pass water until the end of rapid rinse.

MODEL 2930

Water Conditioner Flow Diagrams (Cont'd.)

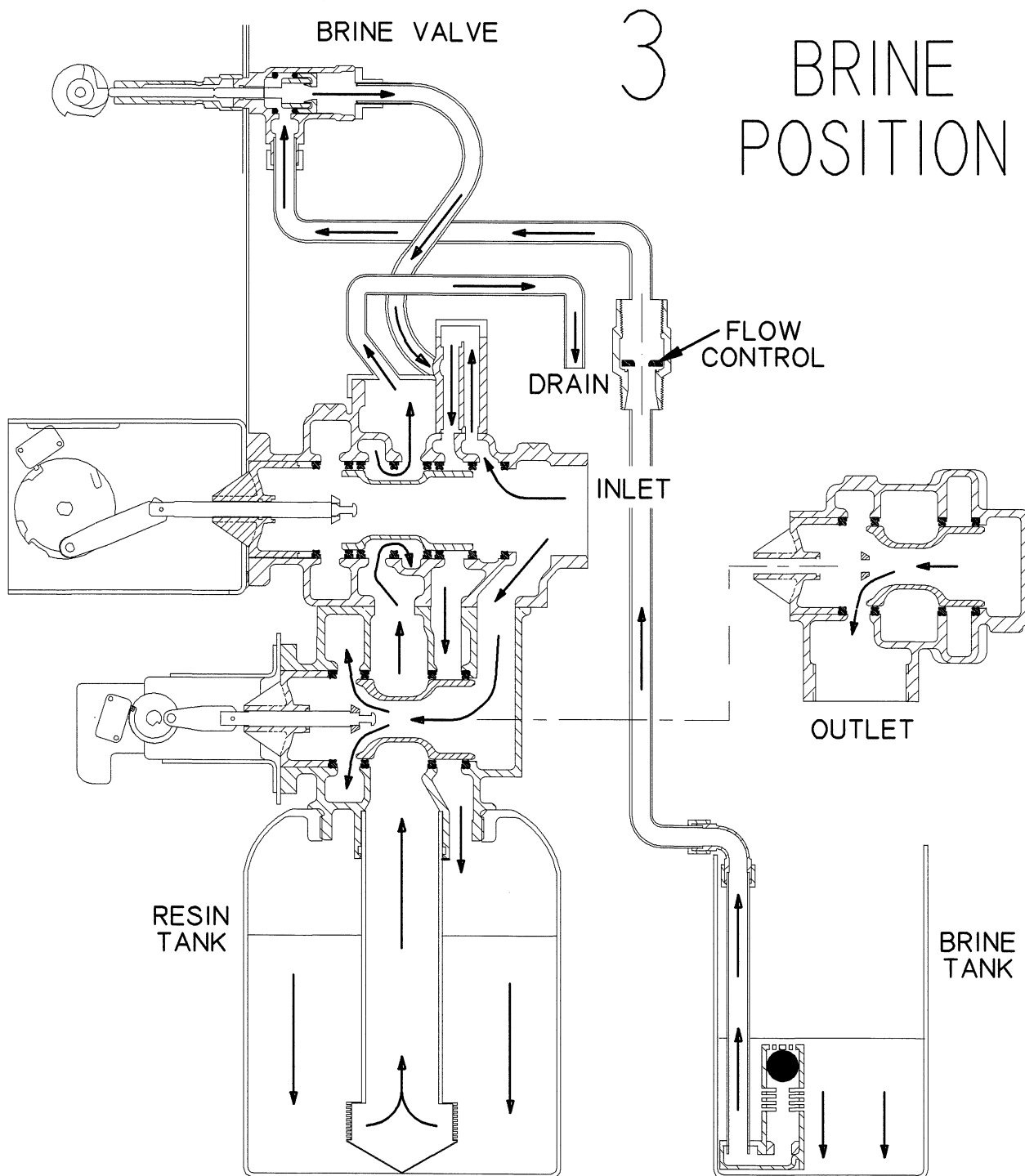

Hard water enters regeneration unit inlet - flows up into injector housing and down thru nozzle and throat to draw brine from brine tank - brine flows down thru mineral and enters the center tube thru bottom distributor - flows up thru center tube - around piston and out thru the drain line.

MODEL 2930

Water Conditioner Flow Diagrams (Cont'd.)

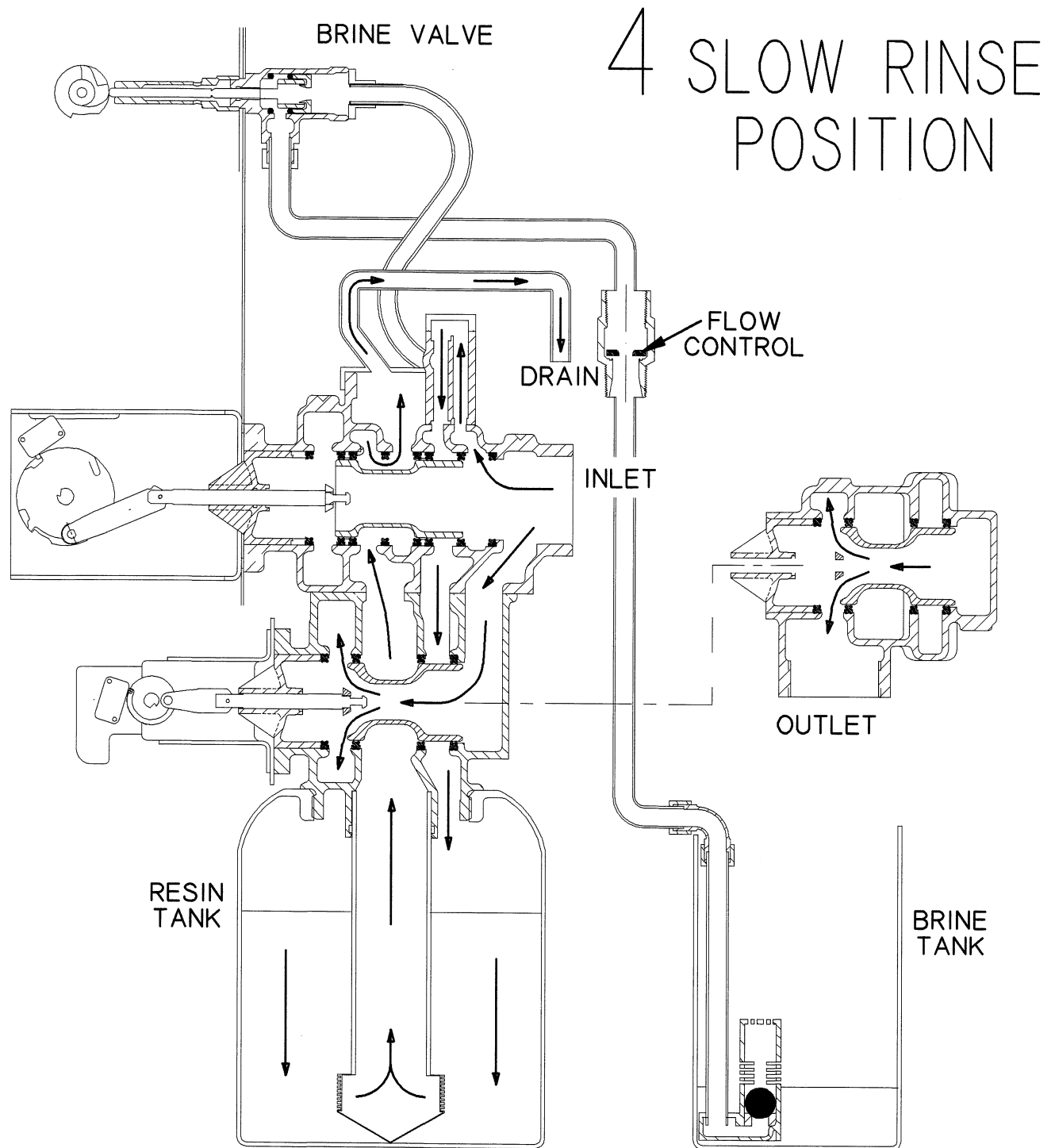

Hard water enters regeneration unit inlet - flows up into injector housing and down thru nozzle and throat - around the piston - down thru mineral - enters center tube thru bottom distributor - flows up thru center tube - around piston and out thru drain line.

MODEL 2930

Water Conditioner Flow Diagrams (Cont'd.)

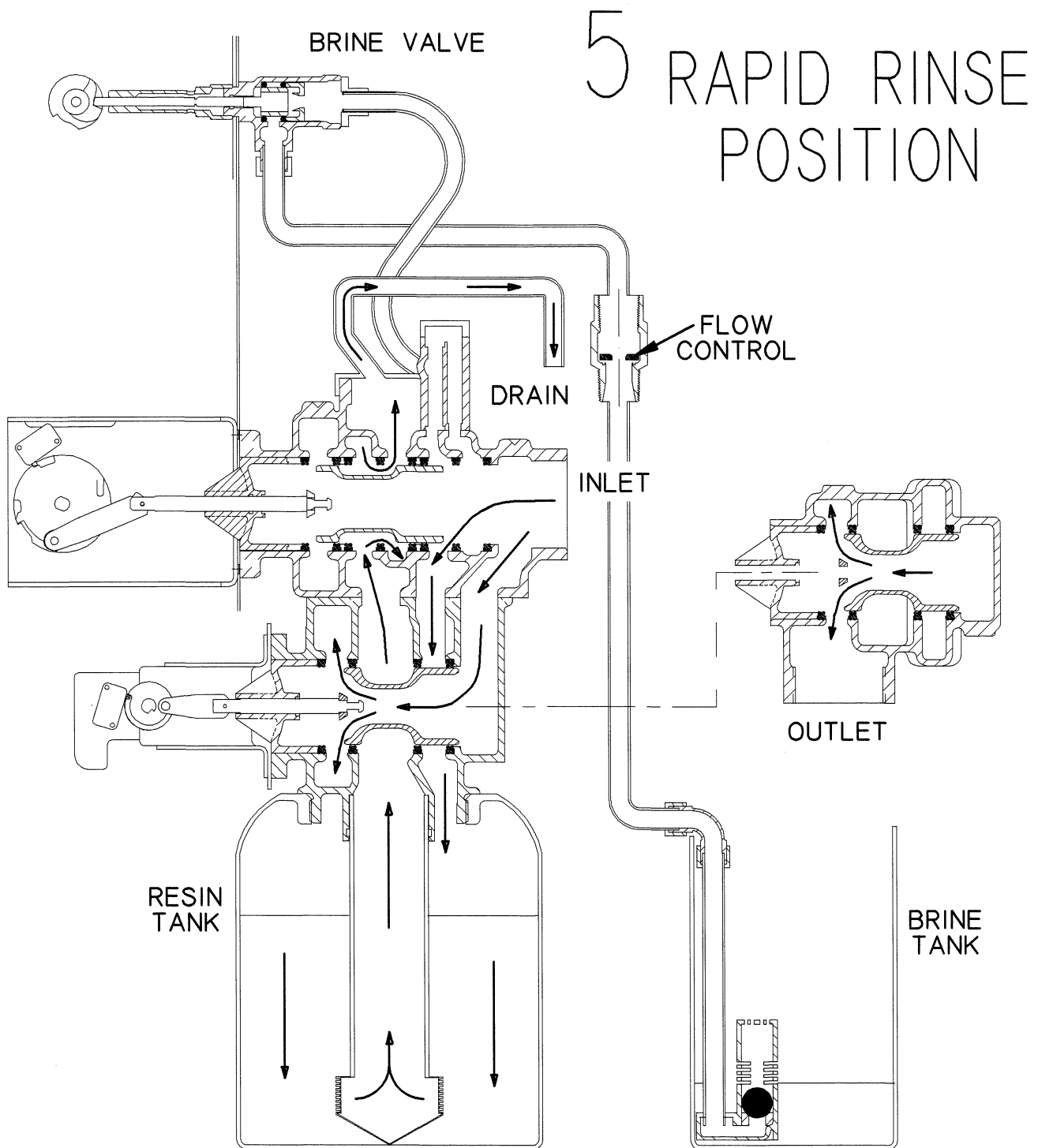

Hard water enters regeneration unit inlet - water goes directly down thru top of tank - thru the mineral into the bottom distributor and up thru the center tube - around the piston and out the drain line.

MODEL 2930

Water Conditioner Flow Diagrams (Cont'd.)

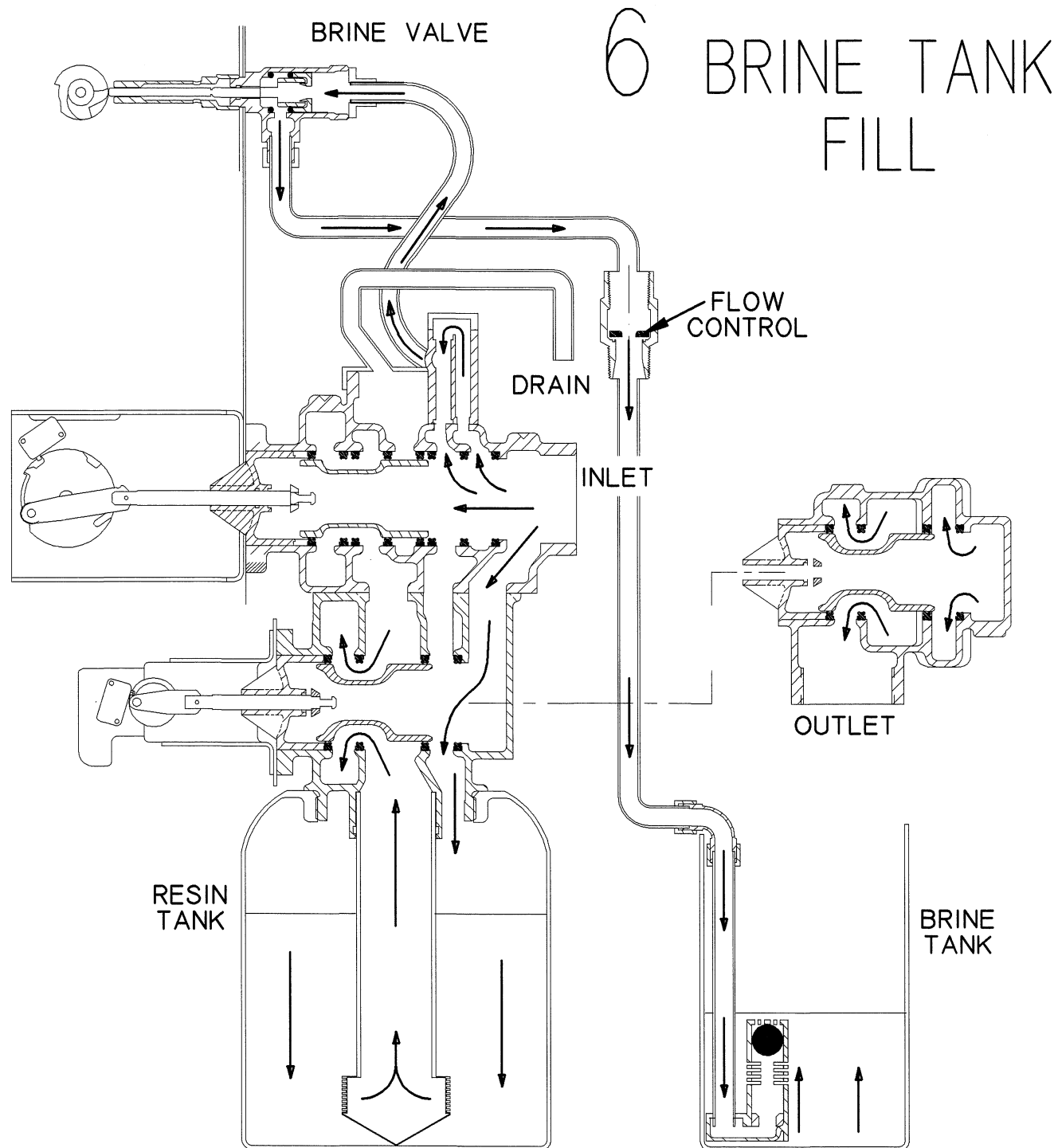

Hard water enters regeneration unit inlet - water flows down into transfer units top of tank - passes thru mineral. Conditioned water enters bottom distributor flows up thru center tube around the piston to the outlet. Hard water flows to the regeneration valve thru the injector housing and brine valve to fill the brine tank.

MODEL 2930

Control Drive Assembly

(See opposite page for parts list)

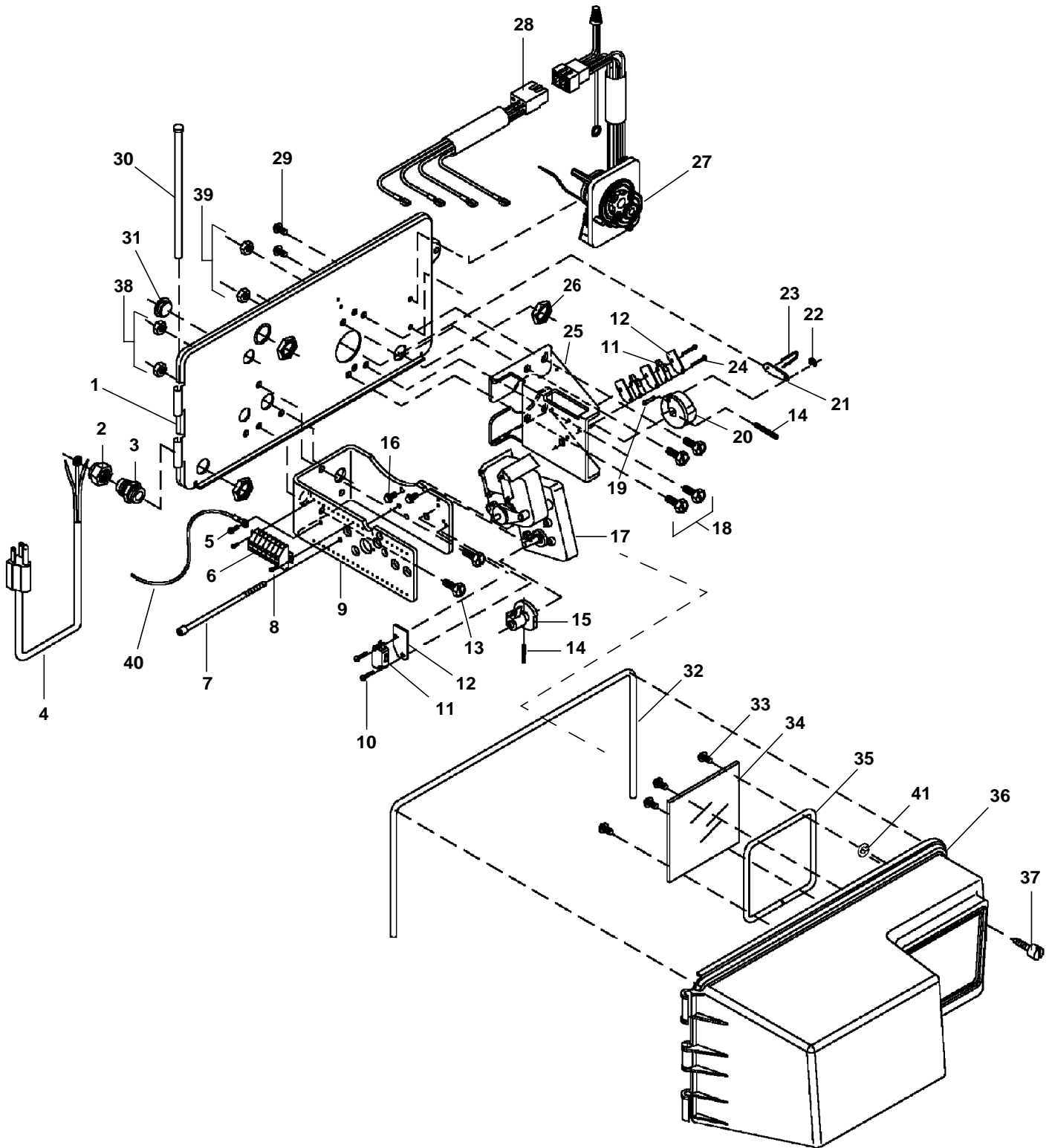

MODEL 2930

Control Drive Assembly

Parts List

Item No.	Quantity	Part No.	Description
1	1	40200-00	Backplate
2	1	17967	Strain Relief
3	1	14924	Strain Relief
4	1	40084-12	12 ft. Power Cord
5	1	40193	Ground Screw
6	1	15226-X	Terminal Strip (X denotes the number of terminals)
7	1	40349	Screw, Brine Deflection
8	2	40133	Screw, Term. Block
9	1	40201	Bracket, Brine
10	2	11805	Screw, Micro Switch
11	3	10218	Switch, Micro
12	3	10302	Insulator
13	2	10231	Screw, Brine Bracket
14	2	10338	Pin, Roll
15	1	12777	Cam, Brine Valve
16	5	10872	Screw, Motor
17	1	40190-1156	Motor, 115V 50/60 Hz
	1	40190-2305	Motor, 230V 50/60 Hz
	1	40190-245	Motor, 24V 50/60 Hz
18	4	11224	Screw, Motor Bracket
19	1	14784	Bearing, Cycle Cam Drive
20	1	40198	Cam, Cycle Downflow
21	1	40197	Link, Drive
22	1	10250	Ring, Retaining
23	1	14813	Clip, Piston Rod
24	2	14923	Screw, Micro Switch
25	1	40202	Bracket, Motor
26	1	17967	Fitting, Liquid Tight
27	1		Timer Assembly
28	1	16430	Harness, Upper Timer
29	2	10300	Screw, Timer
30	1	17845-03	Pin, Hinge
31	2	19692	Plug, Knock Out
32	1	18716-03	Seal, Cover
33	4	19203	Screw, Window Cover
34	1	18745	Window
35	1	18615-02	Seal, Window
36	1	19277-020	Cover, Black
37	1	19813	Screw, Cover
38	2	11235	Nut, Brine Bracket
39	2	16346	Nut, Drive Bracket
40	1	40175-01	Wire, Ground
41	1	19856	Ring, Retaining

MODEL 2930

Control Valve

Parts List

Item No.	Quantity	Part No.	Description
1	1	40243	Valve Body, 2930 Regen.
2	12	11720	Seal
3	7	10369	Spacer
4	2	10368	Spacer
5	1	40204	Piston, 2930 Regen.
6	2	14818	Clip, Piston Rod
7	1	40205	Rod, Piston
8	1	40203	Spacer, Endplug
9	1	14922	O-ring, Endplug
10	1	14754-01	Endplug, White
11	1	14926	Ring, Endplug Quad
12	1	19925	Gasket, Injector Body
13	1	14802-04C	Injector Throat #4 (Green)
		14802-05C	Injector Throat #5 (White)
		14802-06C	Injector Throat #6 (Red)
		14802-07C	Injector Throat #7 (Black)
14	1	17777-03	Injector Body
15	1	13771	O-Ring
16	1	14801-04C	Nozzle, Injector #4 (Green)
		14801-05C	Nozzle, Injector #5 (White)
		14801-06C	Nozzle, Injector #6 (Red)
		14801-07C	Nozzle, Injector #7 (Black)
17	1	10229	Gasket, Injector Cover
18	1	10228	Cap, Brass
19	2	14804	Screw, Injector Body
20	4	40118	Screw, Valve Mounting
21	1	40189	Seal, Base
22	1	40215	2" Adapter Valve
23	1	14753	Spacer, Drain
24	1	14757	Piston, Hard Water Bypass
25	1	14752	Piston, No Hard Water Bypass
26	1	14758	Rod, Piston
27	1	14926	Quad, Endplug
28	1	14922	O-Ring, End Plug
29	1	14754-01	End Plug (White)
		14754-11	End Plug, No Hard Water Bypass (Black)
30	1	13575	O-Ring, Top of Tank
		15210	O-Ring, Top of Tank (Park)
31	1	13577	O-Ring, Distributor
Options			
32	1	40316	Adapter, 2930 Side Mount
33	1	19485	O-Ring, Side Mount 2-141
34	1	XXXXX	O-Ring, Side Mount 2-156
35	1	40310	Base, 2930/3130 Side Mount
36	7	19768	Screw, SHCS

MODEL 2930

Lower Environmental Control Drive

(See opposite page for parts list)

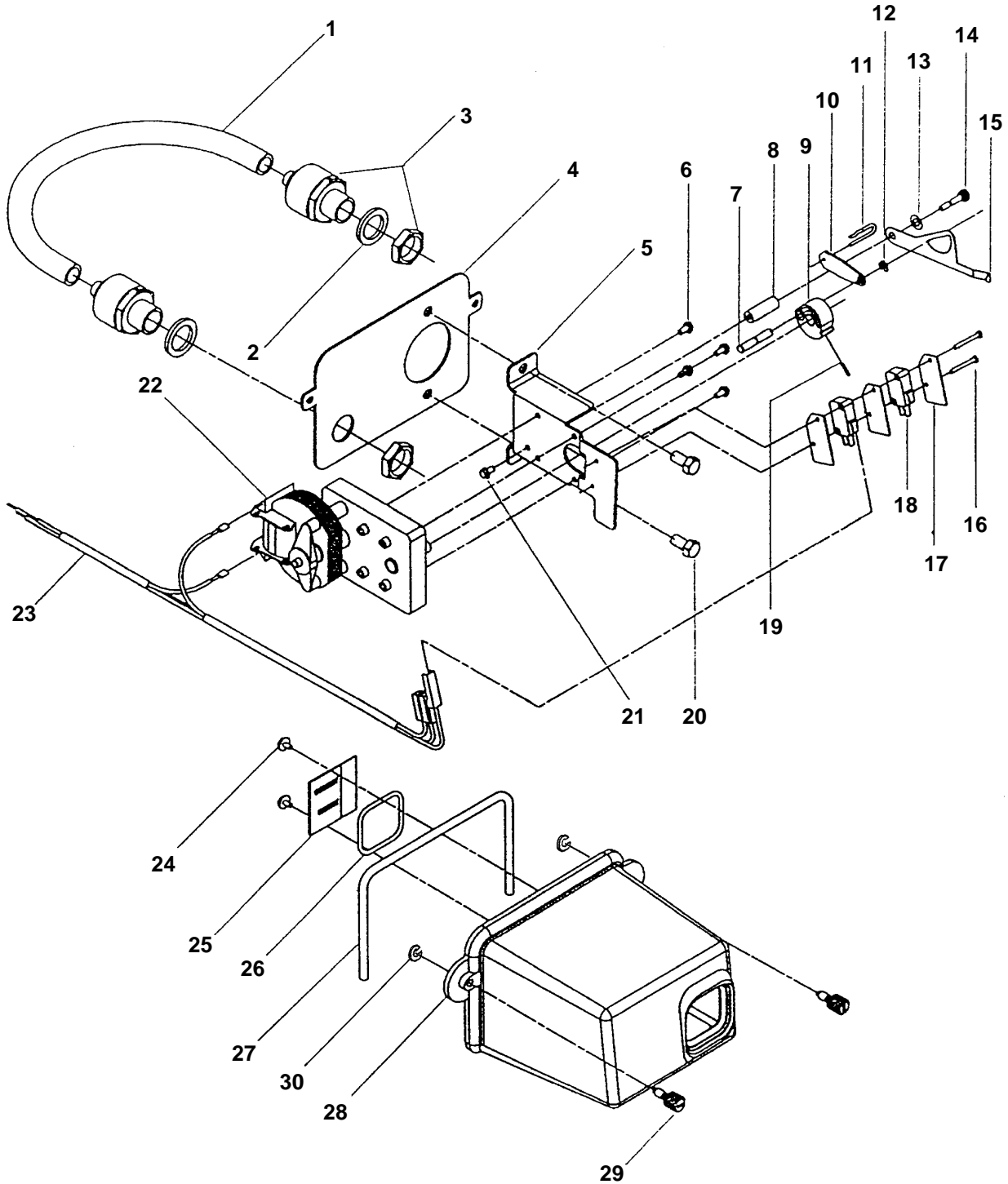

MODEL 2930

Lower Environmental Control Drive

Parts List

Item No.	Quantity	Part No.	Description
1	1	18693	Conduit, Interdrive
2	2	18692	Washer, Sealing
3	2	18691	Connector, Conduit
4	1	18709	Back Plate, Lower
5	1	14769	Bracket, Motor
6	4	10872	Screw, Motor
7	1	18746	Bearing, Connecting Rod
8	1	18726	Spacer, Indicator
9	1	14775	Cam, Drive
10	1	14759	Link, Piston Rod
11	1	14813	Pin, Spring
12	1	10250	Retaining Ring
13	1	18727	Washer, Curved Spring
14	1	10872	Screw, Indicator
15	1	18725	Indicator, Off Line / Service / On Line
16	2	11805	Screw, Switch, System 4
	2	14923	Insulator, Switch, Systems 5, 6 & 7
17	2	10302	Insulator, Switch, System 4
	3	14923	Insulator, Switch, Systems 5, 6 & 7
18	1	10218	Micro Switch, System 4
	2	10218	Micro Switch, Systems 5, 6 & 7
19	1	11381	Pin, Cam
20	2	11224	Screw, Motor Bracket
21	1	10872	Screw, Spacer
22	1	14772	Motor, 110V 50/60 Hz
	1	15305	Motor, 220V 50/60 Hz
	1	15651	Motor, 24V 50 Hz
	1	15653	Motor, 24V 60 Hz
23	1	19015	Wire Harness, System 4
	1	19016	Wire Harness, Systems 5 & 6
	1	19017	Wire Harness, System 7, Lead Valve
	1	19018	Wire Harness, System 7, Lag Valve
24	2	14430	Screw, Window
25	1	18724	Window
26	1	18615-03	Seal, Window
27	1	18716-02	Seal, Cover
28	1	18708-02	Cover, Lower, Black
29	2	19813	Screw, Cover
30	2	19856	Washer, Retaining

MODEL 2930

1705 Brine System

(See opposite page for parts list)

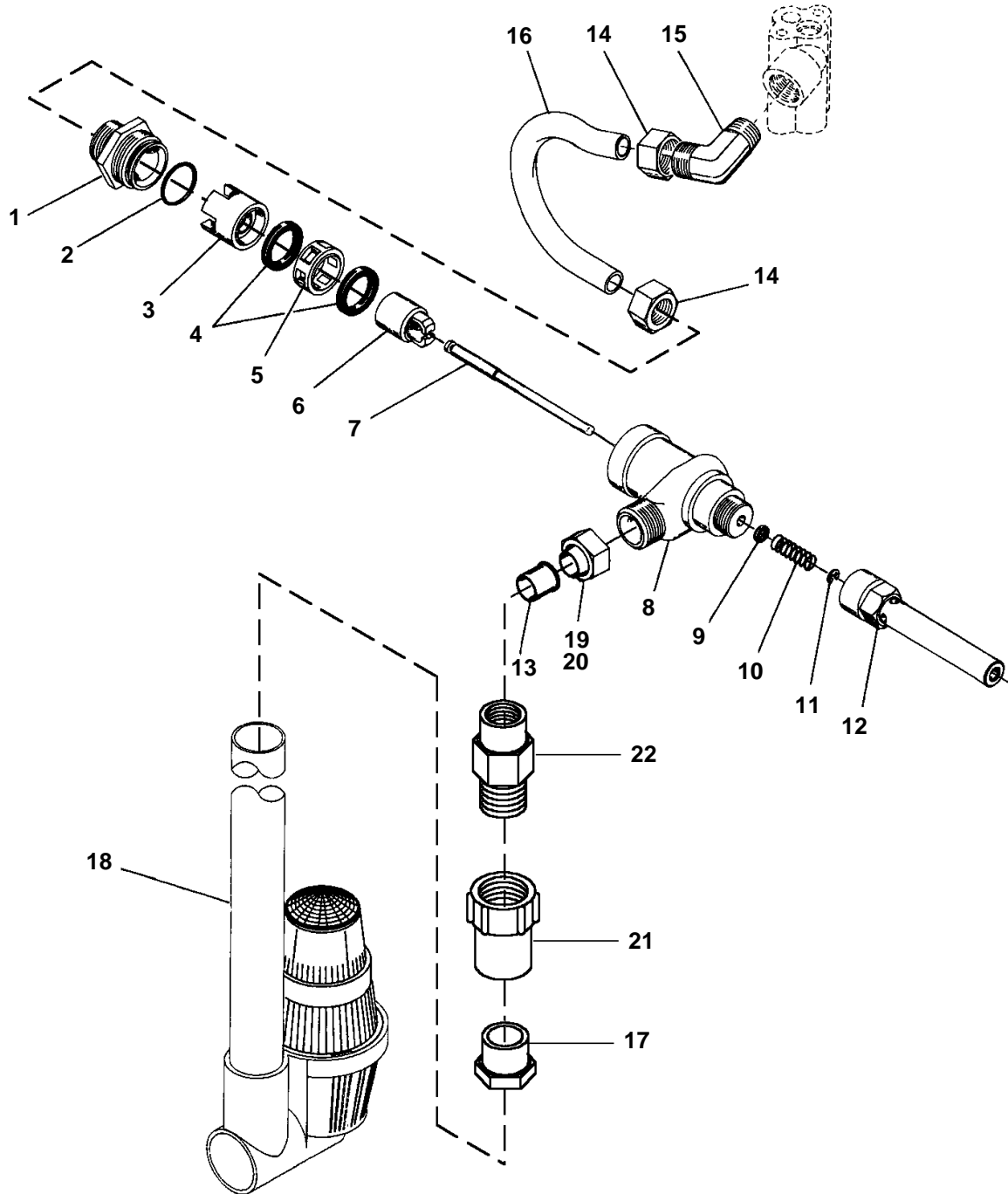

MODEL 2930

1705 Brine System

Parts List

Item No.	Quantity	Part No.	Description
1.....	1	14792	End Plug
2.....	1	13201	O-Ring - End Plug
3.....	1	14785-01	Flow Control Retainer
4.....	2	14811	Piston Seals
5.....	1	14798	Spacer
6.....	1	14795	Brine Valve Piston
7.....	1	40199	Brine Valve Stem
8.....	1	14790	Brine Valve Body
9.....	1	12550	Quad Ring - Brine Stem
10.....	1	15310	Spring - Brine Valve
11.....	1	10250	Retaining Ring
12.....	1	40213	Stem Guide
13.....	2	15415	Insert
14.....	2	15414	Nut Ferrule 1/2"
15.....	1	15413	Elbow
16.....	1	40242	Brine Tube
17.....	1	16976	1" Slip to 3/4" Reducer
18.....	1	60009	#900 Air Check Assembly
19.....	2	16123	Tube Nut 1/2"
20.....	2	16124	Ferrule 1/2"
21.....	1	16975	1" Female NPT x 1" Slip
22.....	1	16530	Housing, BLFC 1" NPT Male x 1" NPT Female
		16530-10.....	Housing, BLFC 1" BSP Male x 1" BSP Female

* Brine valve is not available with internal flow control. External flow control is required.

MODEL 2930

2" Plastic Meter Assembly

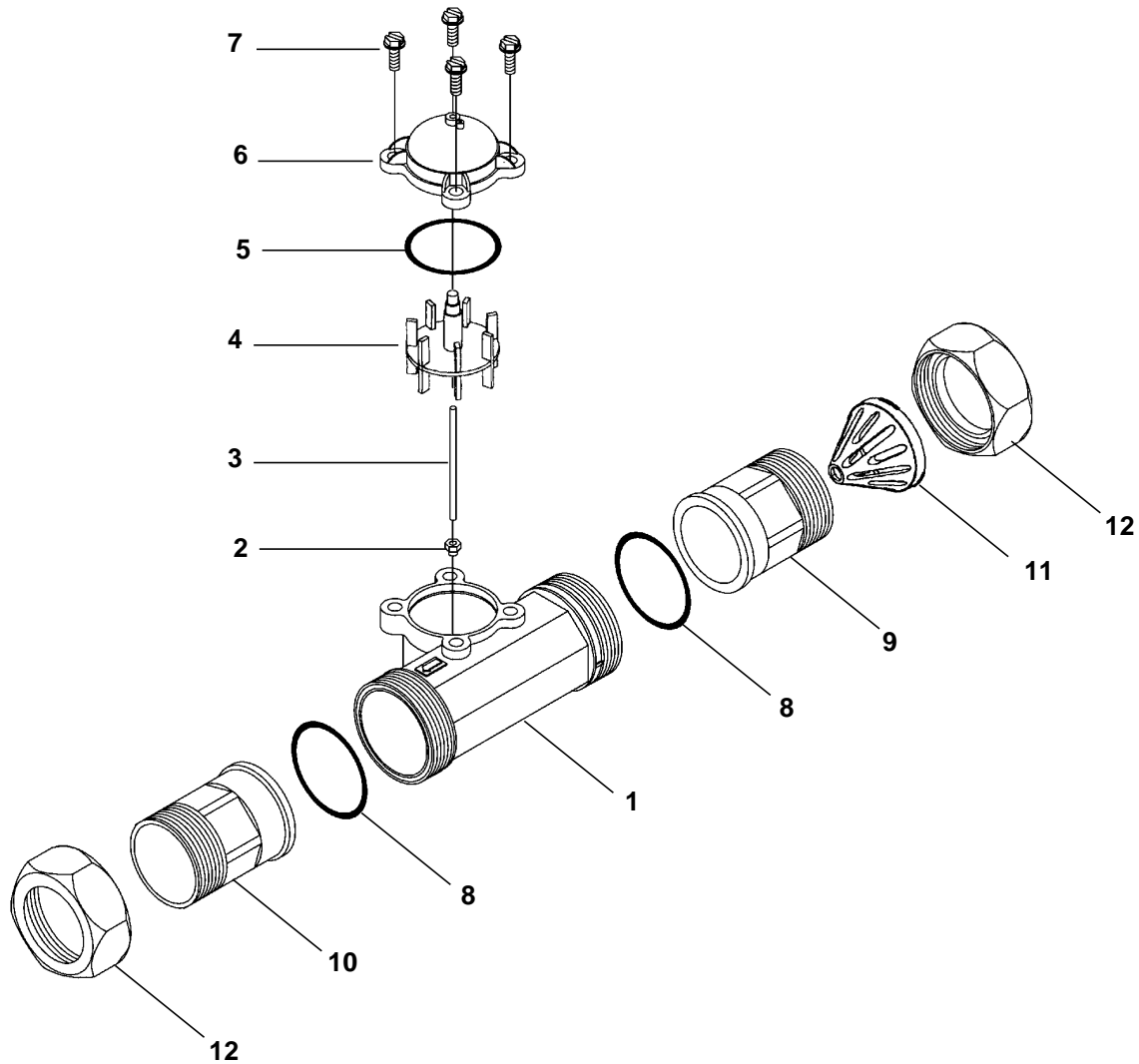

Item No.	Quantity	Part No.	Description
1	1	17689	Body, Meter, 2" Plastic
2	1	15532	Shaft, Impeller Seat
3	1	15432	Shaft, Impeller
4	1	15374	Impeller Assembly, 2" Meter
5	1	13847	O-Ring, -137, Meter
6	1	14038	Meter Cap Assembly (Standard Range)
	1	15150	Meter Cap Assembly (Extended Range)
7	4	12473	Screw, Hex Washer, 10-24 x 5/8
8	2	19485	O-Ring, -141, Meter
9A	1	17987-001	Fitting, Nipple, 2", Plastic, NPT, Machined
9B	1	17987-101	Fitting, Nipple, 2", Plastic, BSP, Machined
10A	1	17987-000	Fitting, Nipple, 2", Plastic, NPT
10B	1	17987-100	Fitting, Nipple, 2", Plastic, BSP
11	1	14680	Flow Straightener
12	2	17988	Nut, 2" Meter

MODEL 2930

2" Brass Meter Assembly

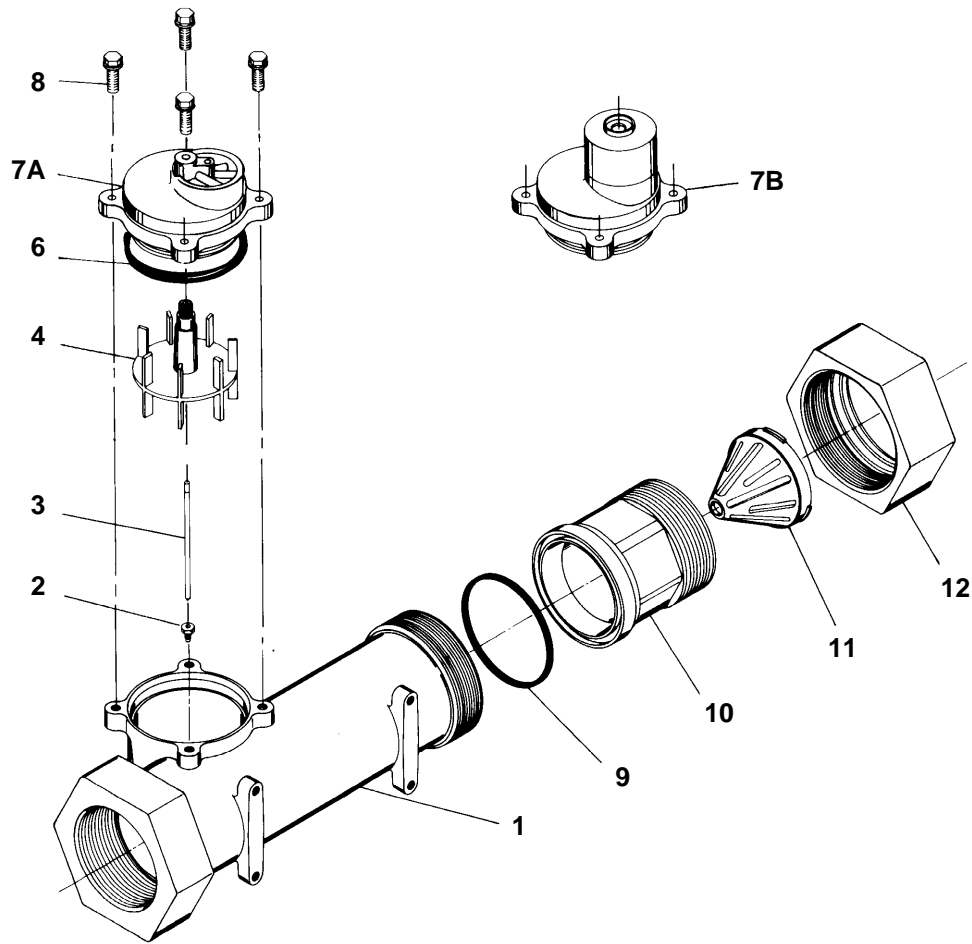

Item No.	Quantity	Part No.	Description
1	1	14456	Meter Body
2	1	15532	Impeller Shaft Retainer
3	1	15432	Impeller Shaft
4	1	15374	Impeller
6	1	13847	O-Ring - Meter Cover
7A	1	15218	Meter Cover Assembly (Standard)
7B	1	15237	Meter Cover Assembly (Extended Range)
8	4	12112	Screw - Meter Cover
9	1	14679	O-Ring - Quick Connect
10	1	14568	Nipple - Quick Connect
11	1	14680	Flow Straightener
12	1	14569	Nut - Quick Connect

MODEL 3210 ECONOMINDER®

Timer Assembly

(See opposite page for parts list)

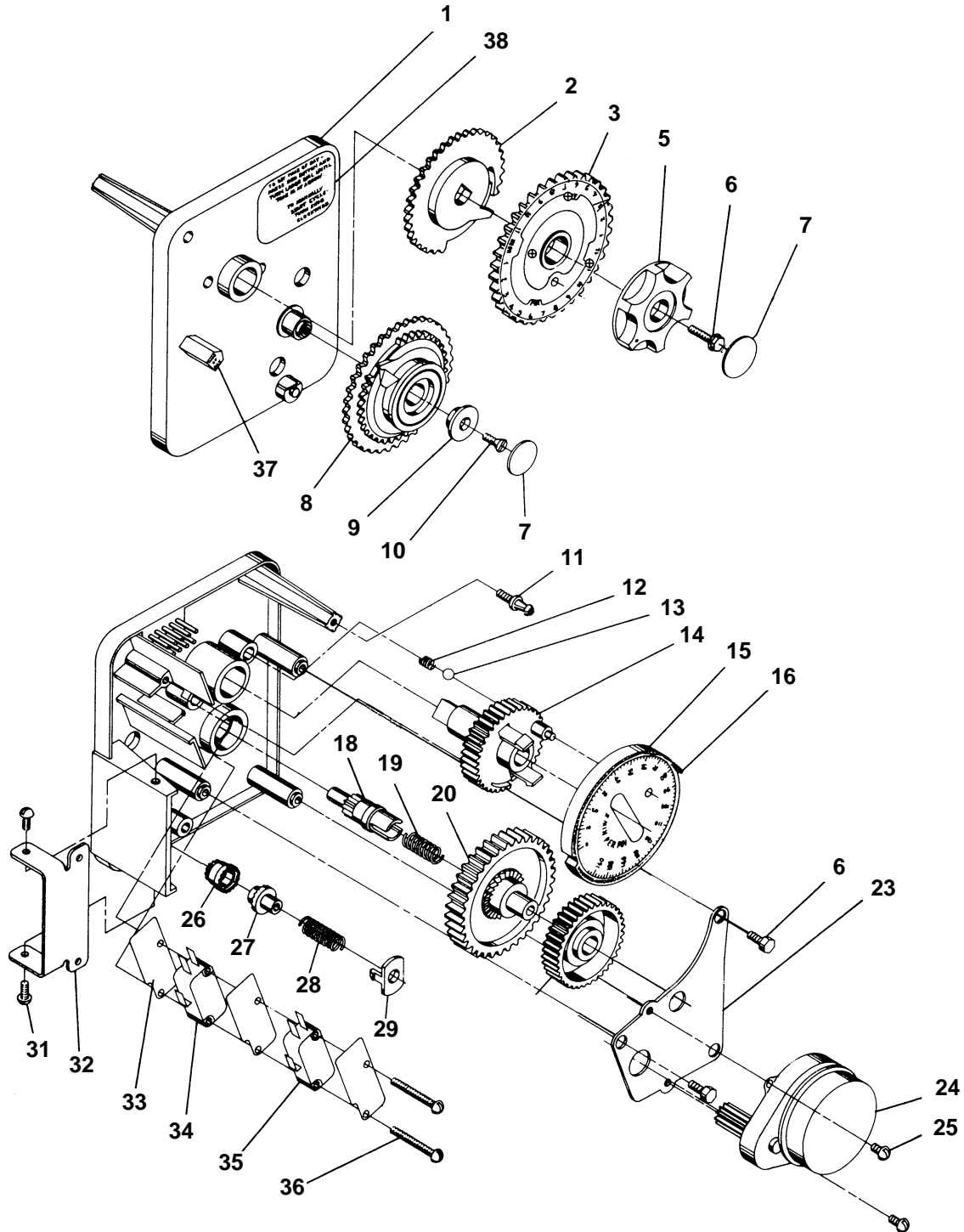

MODEL 3210 ECONOMINDER®

Timer Assembly

Parts List

Item No.	Quantity	Part No.	Description
1	1	13870-01	Timer Housing Assembly
2	1	13802	Cycle Actuator Gear
3	1	40096-24	24 Hour Gear Assembly, 12 Midnight
		40096-02	24 Hour Gear Assembly, 2 A.M.
5	1	13886-01	Knob
6	4	13296	Screw - Timer Knob & Motor Plate Mtg.
7	2	11999	Button Decal
8	1	60405-50	Program Wheel Assembly, 0-21,000
9	1	13806	Program Wheel Retainer
10	1	13748	Screw - Program Wheel Mtg.
11	1	14265	Spring Clip
12	1	15424	Spring-Detent
13	1	15066	Ball - 1/4 in. dia.
14	1	13911	Main Drive Gear
15	1	19210	Program Wheel Assembly
16	21	15493	Roll Pin
17			Not Assigned
18	1	13018	Idler Shaft
19	1	13312	Spring - Idler
20	1	13017	Idler Gear
21	1	13164	Drive Gear
23	1	13887	Motor Mounting Plate
24	1	18743	Motor - 110V., 60 Hz.
		19659	Motor - 24V., 60 Hz.
25	2	13278	Screw - Motor Mounting
26	1	13830	Drive Pinion - Program Wheel
27	1	13831	Clutch - Drive Pinion
28	1	14276	Spring
29	1	14253	Spring Retainer
30			Not Assigned
31	3	11384	Screw - Timer Hinge & Ground Wire
32	1	13881	Hinge Bracket
33	3	14087	Insulator
34	1	10896	Switch
35	1	15320	Switch
36	2	11413	Screw - Switch Mounting
37	1	14007	Decal - Time of Day
38	1	14045	Decal - Instructions
39	1	13902	Harness - Not Shown
40	2	12681	Wire Connector - Not Shown
41	1	15354-01	Ground Wire - Not Shown
42	1	15465	Caution Label - Not Shown
43	1	14198	Capacity Label - Not Shown

MODEL 2930 ECONOMINDER®

2" Commercial Demand Regeneration Control Timer Settings

Typical Programming Procedure

Calculate the gallon capacity of the system, subtract the necessary reserve requirement and set the gallons available opposite the small white dot on the program wheel gear. Note, drawing shows 8,750 gallon setting. The capacity (gallons) arrow denotes remaining gallons exclusive of fixed reserve.

How To Set The Time Of Day:

Press and hold the red button in to disengage the drive gear.

Turn the large gear until the actual time of day is opposite the time of day pointer.

Release the red button to again engage the drive gear.

How To Manually Regenerate Your Water Conditioner At Any Time:

Turn the manual regeneration knob clockwise.

This slight movement of the manual regeneration knob engages the program wheel and starts the regeneration program.

The black center knob will make one revolution in the following approximately three hours and stop in the position shown in the drawing.

Even though it takes three hours for this center knob to complete one revolution, the regeneration cycle of your unit might be set for only one half of this time.

In any event, conditioned water may be drawn after rinse water stops flowing from the water conditioner drain line.

Immediate Regeneration Timers:

These timers do not have a 24 hour gear. Setting the gallons on the program wheel and manual regeneration procedure are the same as previous instructions.

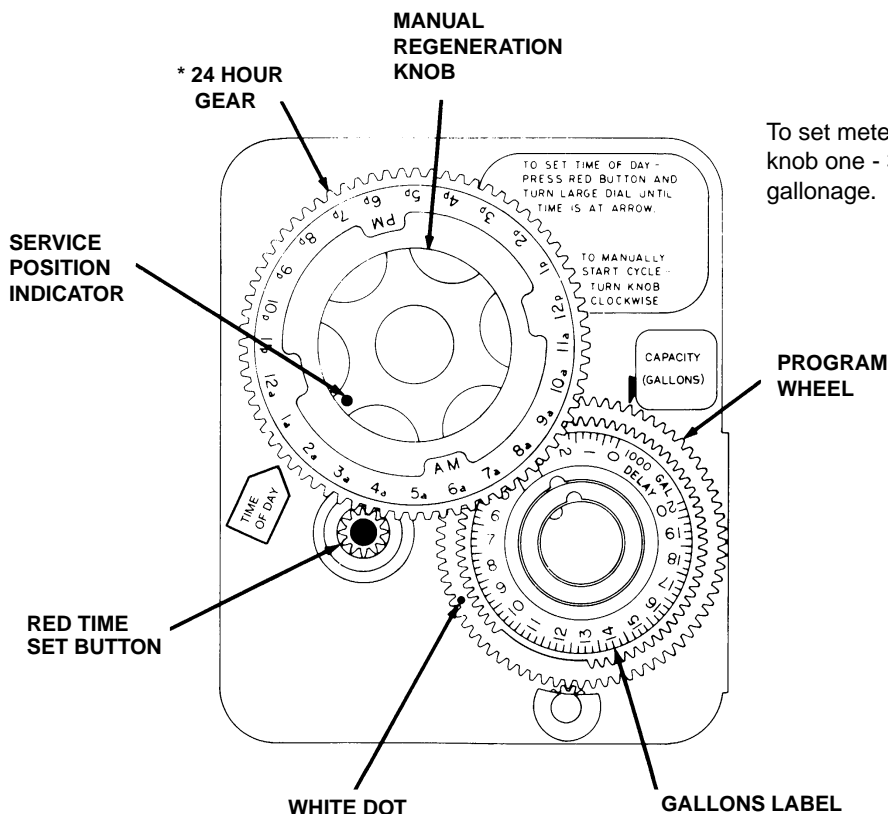

NOTE:

To set meter capacity rotate manual knob one - 360° revolution to set gallonage.

* Immediate regeneration timers do not have 24 hour gear. No time of day can be set.

MODEL 3200 TIMER

Timer Setting Procedure

How To Set Days On Which Water Conditioner Is To Regenerate:

Rotate the skipper wheel until the number "1" is at the red pointer. Set the days that regeneration is to occur by sliding tabs on the skipper wheel outward to expose trip fingers. Each tab is one day. Finger at red pointer is tonight. Moving clockwise from the red pointer, extend or retract fingers to obtain the desired regeneration schedule.

How To Set The Time Of Day:

Press and hold the red button in to disengage the drive gear. Turn the large gear until the actual time of day is at the time of day pointer.

Release the red button to again engage the drive gear.

How To Manually Regenerate Your Water Conditioner At Any Time:

Turn the manual regeneration knob clockwise.

This slight movement of the manual regeneration knob engages the program wheel and starts the regeneration program.

The black center knob will make one revolution in the following approximately three hours and stop in the position shown in the drawing.

Even though it takes three hours for this center knob to complete one revolution, the regeneration cycle of your unit might be set only one half of this time.

In any event, conditioned water may be drawn after rinse water stops flowing from the water conditioner drain line.

How to Adjust Regeneration Time:

1. Disconnect the power source.
2. Locate the three screws behind the manual regeneration knob by pushing the red button in and rotating the 24 hour dial until each screw appears in the cut out portion of the manual regeneration knob.
3. Loosen each screw slightly to release the pressure on the time plate from the 24 hour gear.
4. Locate the regeneration time pointer on the inside of the 24 hour dial in the cut out.
5. Turn the time plate so the desired regeneration time aligns next to the raised arrow.
6. Push the red button in and rotate the 24 hour dial. Tighten each of the three screws.
7. Push the red button and locate the pointer one more time to ensure the desired regeneration time is correct.
8. Reset the time of day and restore power to the unit.

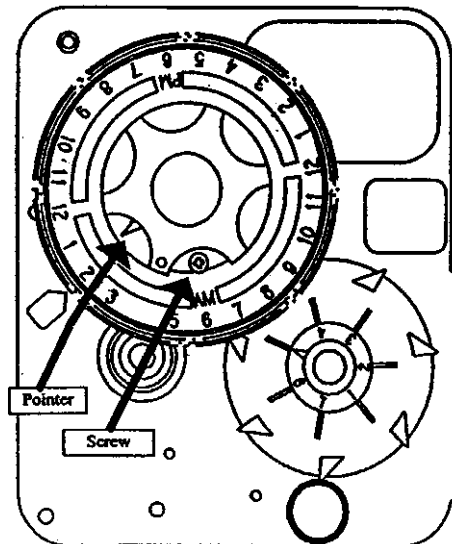
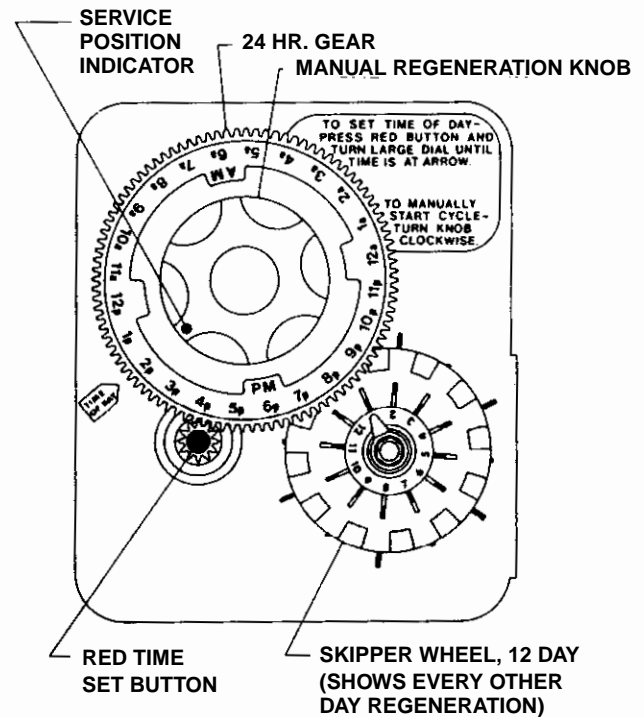

3200 ADJUSTABLE REGENERATION TIMER

MODEL 3200 & 3210 TIMER SERIES

Regeneration Cycle Program Setting Procedure

(Brine Tank Refill Separate From Rapid Rinse)

How To Set The Regeneration Cycle Program:

The regeneration cycle program on your water conditioner has been factory preset, however, portions of the cycle or program may be lengthened or shortened in time to suit local conditions.

3200 & 3210 Series Timers (Figure to Right)

To expose cycle program wheel, grasp timer in upper left-hand corner and pull, releasing snap retainer and swinging timer to the right

To change the regeneration cycle program, the program wheel must be removed. Grasp program wheel and squeeze protruding lugs toward center, lift program wheel off timer. (Switch arms may require movement to facilitate removal.)

Return timer to closed position engaging snap retainer in back plate. Make certain all electrical wires locate above snap retainer post

Timer Setting Procedure for 3200 & 3210 Timer

How To Change The Length Of The Backwash Time:

The program wheel as shown in the drawing is in the service position. As you look at the numbered side of the program wheel, the group of pins starting at zero determines the length of time your unit will backwash.

FOR EXAMPLE: If there are six pins in this section, the time of backwash will be 12 min. (2 min. per pin). To change the length of backwash time, add or remove pins as required. The number of pins times two equals the backwash time in minutes.

How To Change The Length Of Brine And Rinse Time:

The group of holes between the last pin in the backwash section and the second group of pins determines the length of time that your unit will brine and rinse (2 min. per hole.)

To change the length of brine and rinse time, move the rapid rinse group of pins to give more or fewer holes in the brine and rinse section. Number of holes times two equals brine and rinse time in minutes.

How To Change The Length Of Rapid Rinse:

The second group of pins on the program wheel determines the length of time that your water conditioner will rapid rinse. (2 min. per pin.)

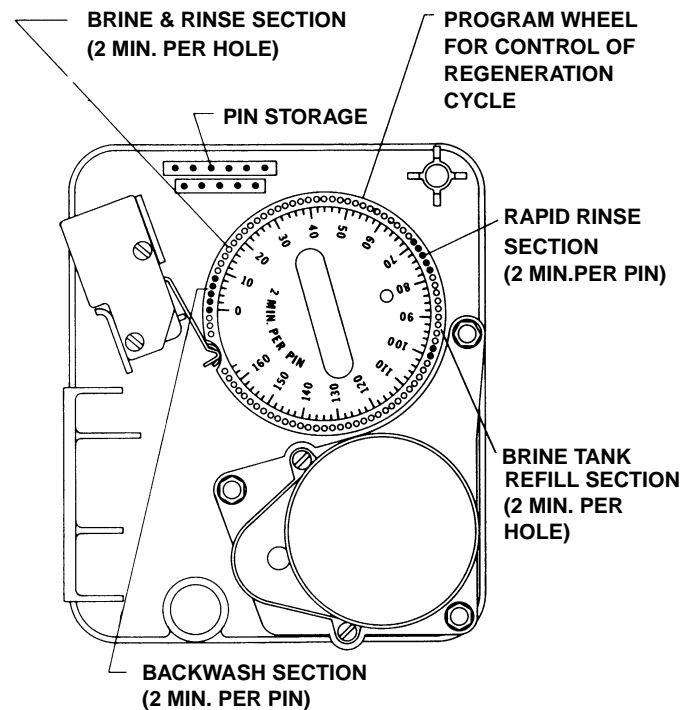

See Page 23 For Typical Timer Settings

To change the length of rapid rinse time, add or remove pins at the higher numbered end of this section as required. The number of pins times two equals the rapid rinse time in minutes.

How To Change The Length Of Brine Tank Refill Time:

The second group of holes in the program wheel determines the length of time that your water conditioner will refill the brine tank (2 min. per hole.)

To change the length of refill time, move the two pins at the end of the second group of holes as required.

The regeneration cycle is complete when the outer microswitch is tripped by the two pin set at end of the brine tank refill section.

The program wheel, however, will continue to rotate until the inner micro-switch drops into the notch on the program wheel.

MODEL 2930

Service Instructions

PROBLEM	CAUSE	CORRECTION
1. Softener fails to regenerate.	A. Electrical service to unit has been interrupted. B. Timer is defective. C. Power failure.	A. Assure permanent electrical service (check fuse, plug, pull chain or switch). B. Replace timer. C. Reset time of day.
2. Hard water.	A. By-pass valve is open. B. No salt in brine tank C. Injector screen plugged. D. Insufficient water flowing into brine tank E. Hot water tank hardness. F. Leak at distributor tube. G. Internal valve leak H. Service adapter did not return to service.	A. Close by-pass valve. B. Add salt to brine tank and maintain salt level above water level. C. Clean injector screen. D. Check brine tank fill time and clean brine line flow control if plugged. E. Repeated flushings of the hot water tank is required. F. Make sure distributor tube is not cracked. Check O-ring and tube pilot. G. Replace seals and spacers and/or piston. H. Check drive motor and switch.
3. Unit used too much salt	A. Improper salt setting. B. Excessive water in brine tank	A. Check salt usage and salt setting. B. See problem No. 7.
4. Loss of water pressure.	A. Iron buildup in line to water conditioner. B. Iron buildup in water conditioner. C. Inlet of control plugged due to foreign material broken loose from pipes by recent work done on plumbing system.	A. Clean line to water conditioner. B. Clean control and add mineral cleaner to mineral bed. Increase frequency of regeneration. C. Remove piston and clean control.
5. Loss of mineral through drain line.	A. Air in water system. B. Improperly sized drain line flow control.	A. Assure that well system has proper air eliminator control. Check for dry well condition. B. Check for proper drain rate.
6. Iron in conditioned water.	A. Fouled mineral bed.	A. Check backwash, brine draw and brine tank fill. Increase frequency of regeneration. Increase backwash time.

(Continued on next page)

MODEL 2930

Service Instructions (Cont'd.)

PROBLEM	CAUSE	CORRECTION
7. Excessive water in brine tank.	A. Plugged drain line flow control. B. Plugged injector system. C. Timer not cycling. D. Foreign material in brine valve. E. Foreign material in brine line flow control.	A. Clean flow control. B. Clean injector and screen. C. Replace timer. D. Replace brine valve seat and clean valve. E. Clean brine line flow control.
8. Softener fails to draw brine.	A. Drain line flow control is plugged. B. Injector is plugged. C. Injector screen plugged. D. Line pressure is too low. E. Internal control leak F. Service adapter did not cycle.	A. Clean drain line flow control. B. Clean injector. C. Clean screen. D. Increase line pressure to 20 p.s.i. E. Change seals, spacers and piston assembly. F. Check drive motor and switches.
9. Control cycles continuously.	A. Misadjusted, broken or shorted switch.	A. Determine if switch or timer is faulty and replace it or replace complete power head.
10. Drain flows continuously.	A. Valve is not programming correctly. B. Foreign material in control. C. Internal control leak	A. Check timer program and positioning of control. Replace power head assembly if not positioning properly. B. Remove power head assembly and inspect bore. Remove foreign material and check control in various regeneration positions. C. Replace seals and piston assembly.

General Service Hints For Meter Control

Problem: Softener Delivers Hard Water.

Cause could be that . . . Reserve Capacity Has Been Exceeded.

Correction: Check salt dosage requirements and reset program wheel to provide additional reserve.

Cause could be that . . . Program Wheel Is Not Rotating With Meter Output

Correction: Pull cable out of meter cover and rotate manually. Program wheel must move without binding and clutch must give positive "clicks" when program wheel strikes regeneration stop. If it does not, replace timer.

Cause could be that . . . Meter Is Not Measuring Flow.

Correction: Check meter with meter checker.

MODEL 2930

Flow Data & Injector Draw Rates

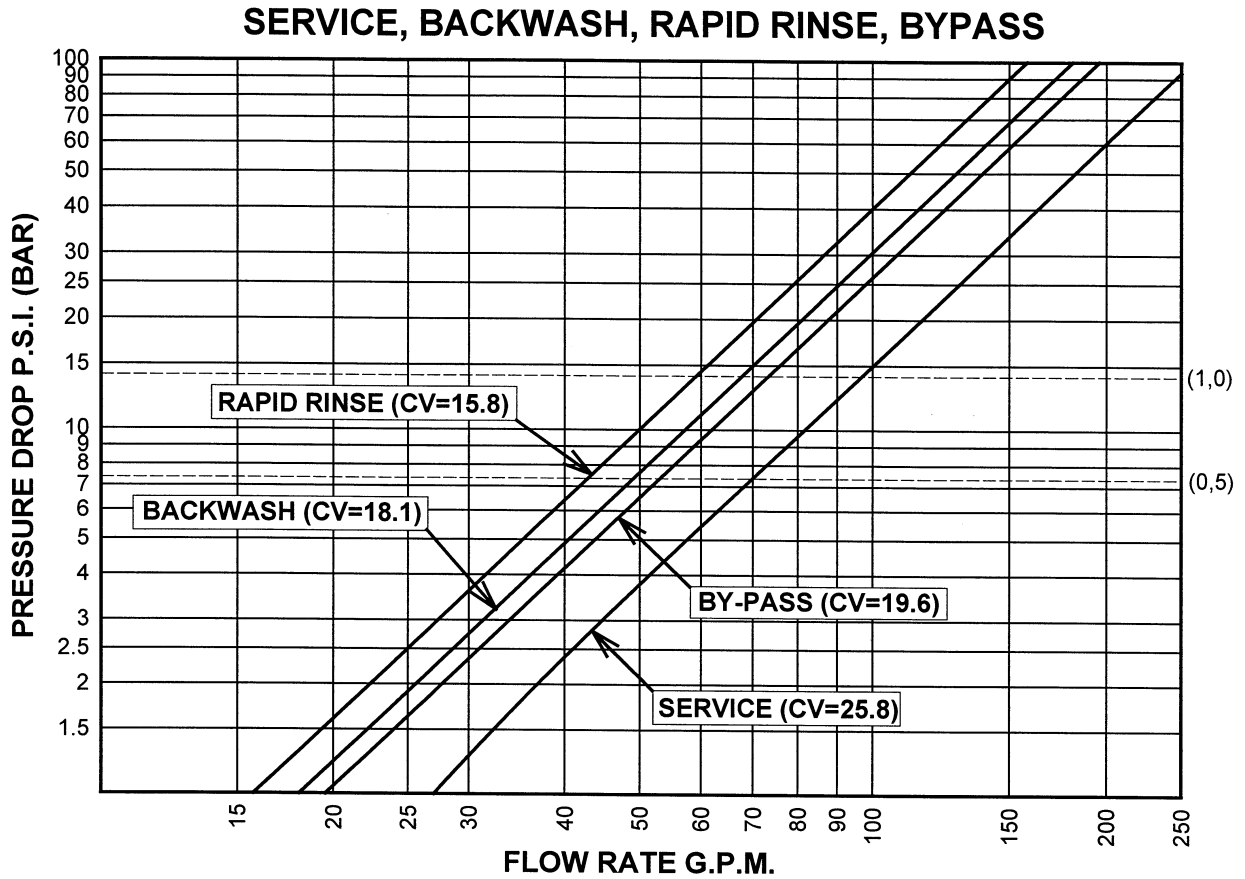

Confidential Property of Fleck Controls

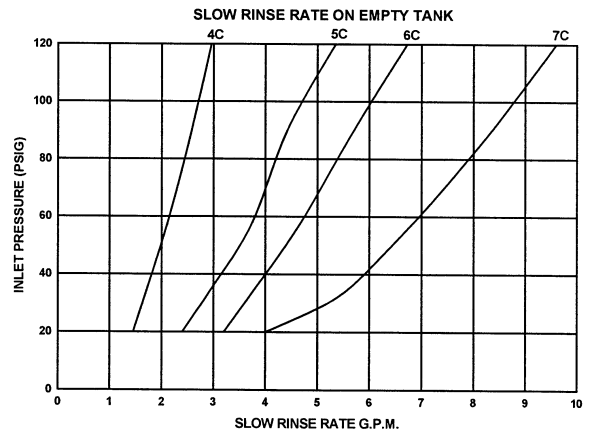
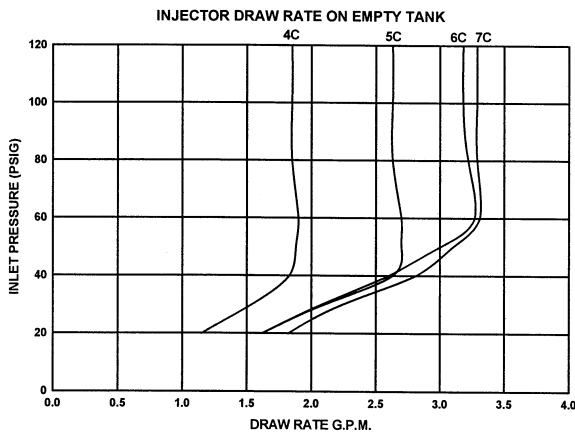

SYSTEM #4

Single Metered System Wiring Diagram

Immediate or Delayed Regeneration

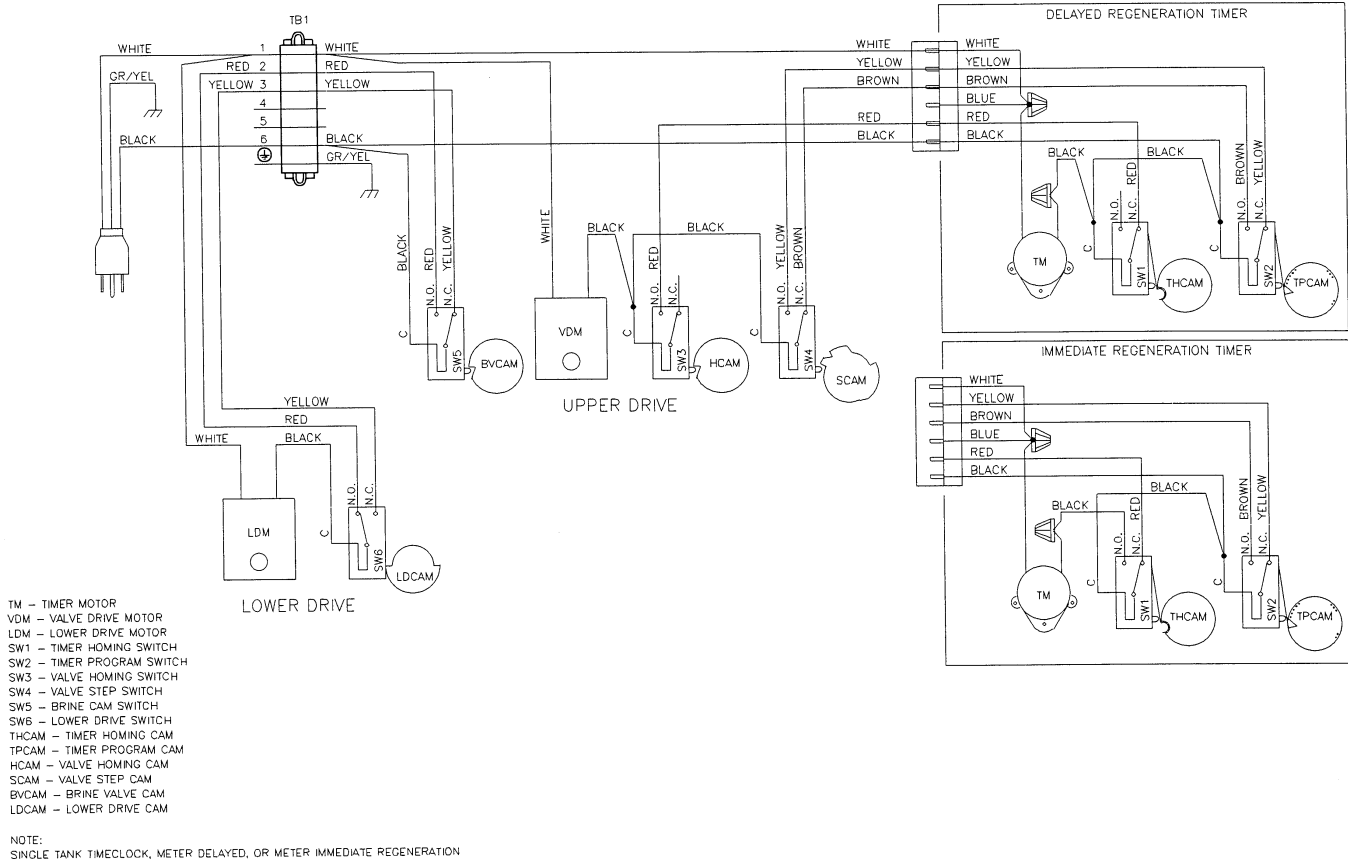

- A. Delayed Regeneration: 1 tank; 1 meter system. When the meter zeroes out, the unit remains in service until 2:00 a.m. At that time it will regenerate automatically.
- B. Immediate Regeneration: 1 tank; 1 meter. When the meter zeroes out, the unit goes immediately into a regeneration.

SYSTEM #4 WITH REMOTE METER

Single Metered System Wiring Diagram

Immediate or Delayed Regeneration

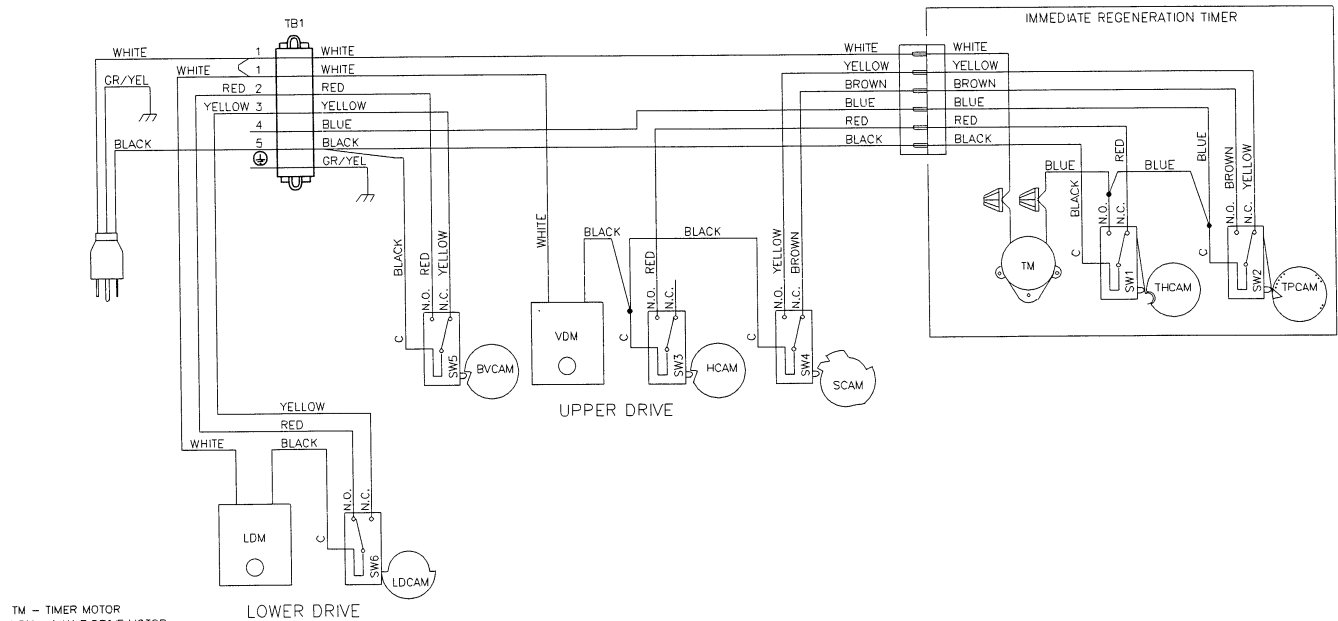

- TM - TIMER MOTOR
- VDM - VALVE DRIVE MOTOR
- LDM - LOWER DRIVE MOTOR
- SW1 - TIMER HOMING SWITCH
- SW2 - TIMER PROGRAM SWITCH
- SW3 - VALVE HOMING SWITCH
- SW4 - VALVE STEP SWITCH
- SW5 - BRINE CAM SWITCH
- SW6 - LOWER DRIVE SWITCH
- THCAM - TIMER HOMING CAM
- TPCAM - TIMER PROGRAM CAM
- HCAM - VALVE HOMING CAM
- SCAM - VALVE STEP CAM
- BVCAM - BRINE VALVE CAM
- LDCAM - LOWER DRIVE CAM

NOTE:
SINGLE TANK REMOTE METER DELAYED, OR IMMEDIATE REGENERATION

REMOTE METER WIRING

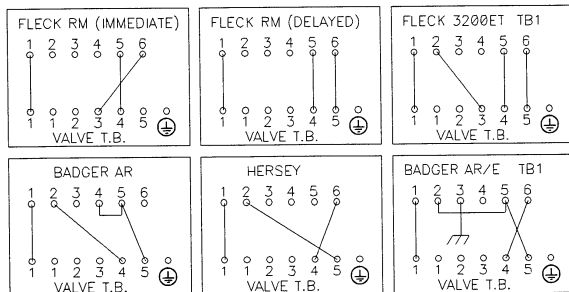

SYSTEM #5

2 Meter Interlock Wiring Diagram

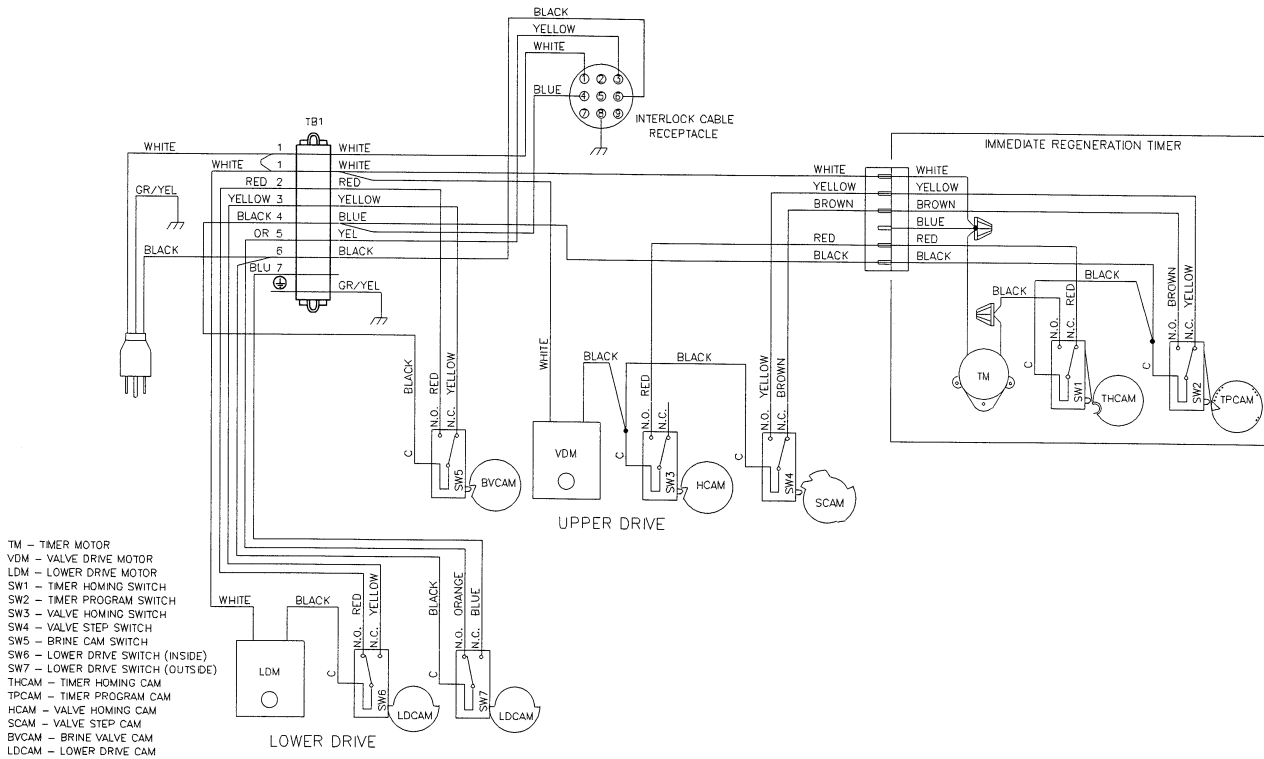

NOTE:
TWO TANK INTERLOCKED, INDIVIDUAL METER, IMMEDIATE REGENERATION.
ONLY ONE TANK IN REGENERATION THE OTHER IN SERVICE.

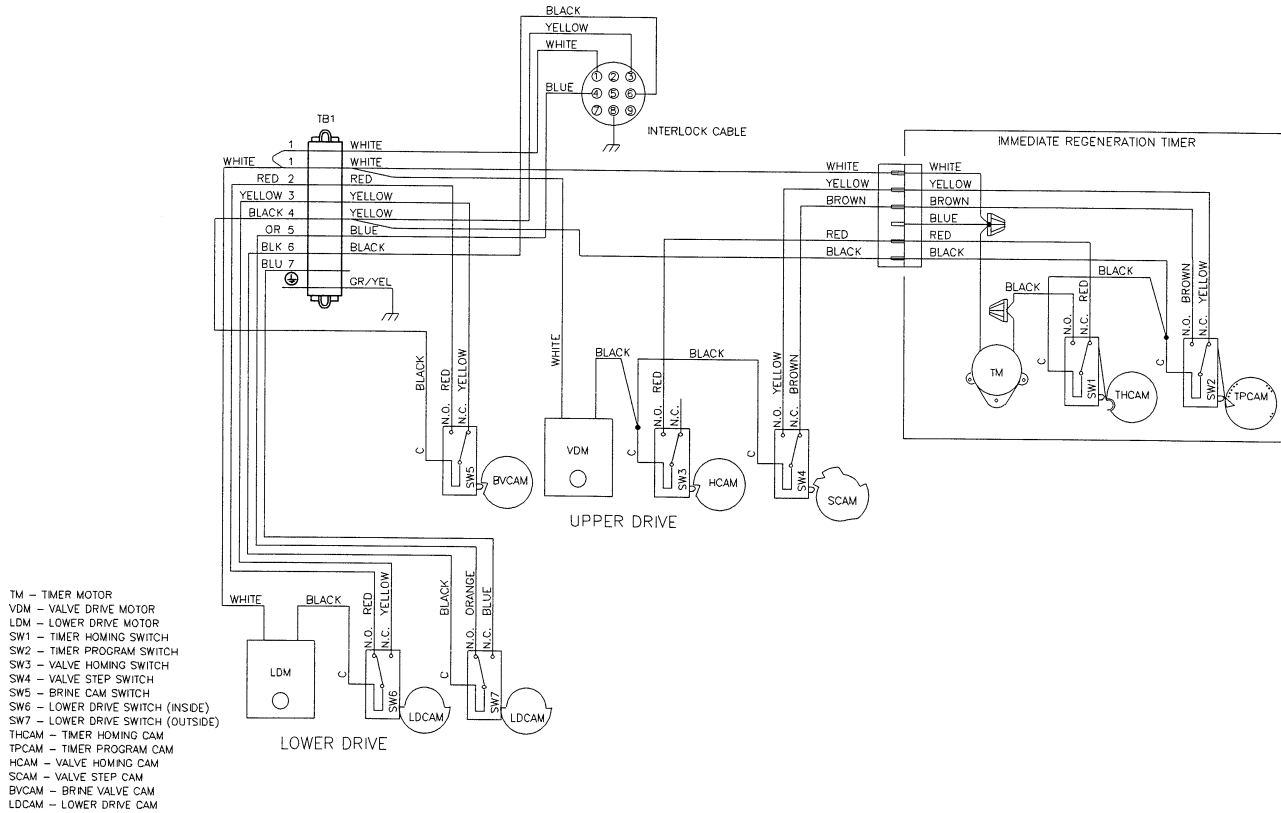

SYSTEM #6

Series Regeneration Wiring Diagram

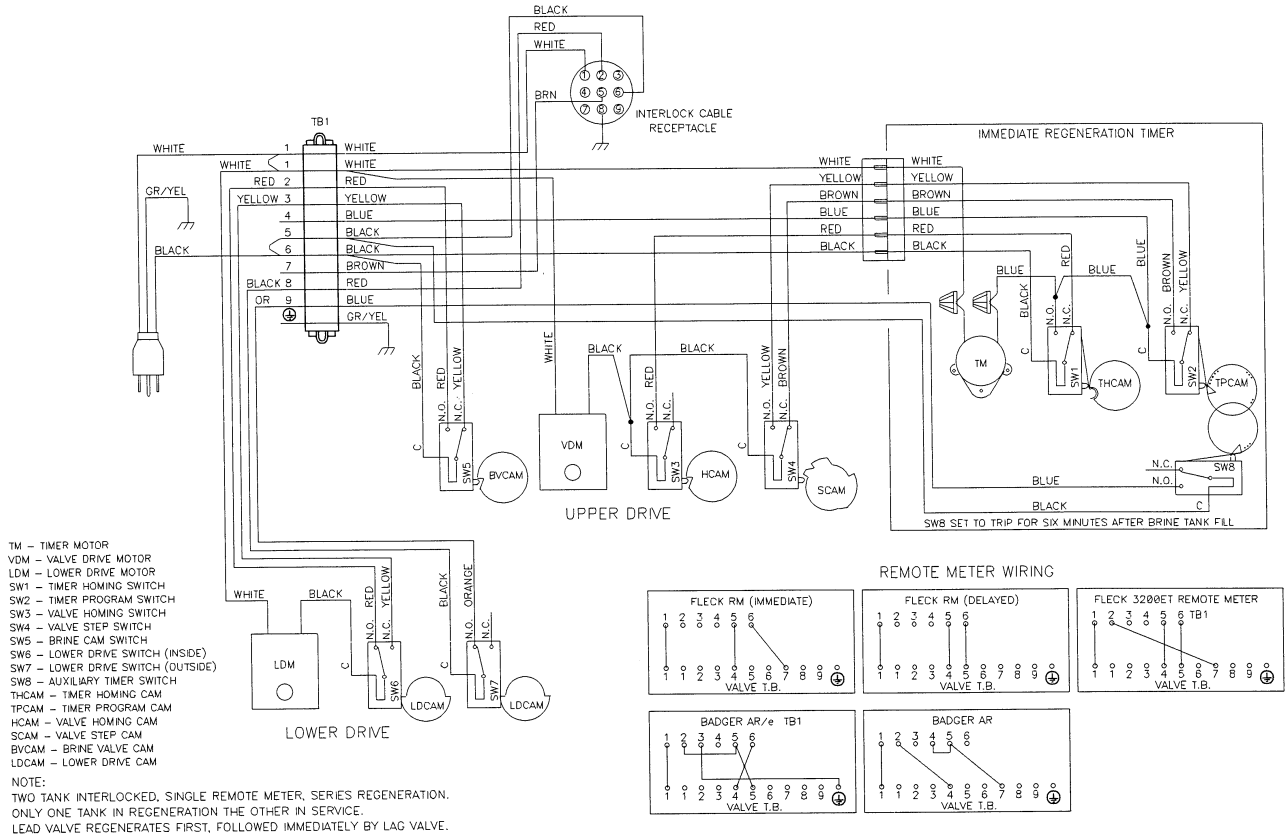

REMOTE METER WIRING

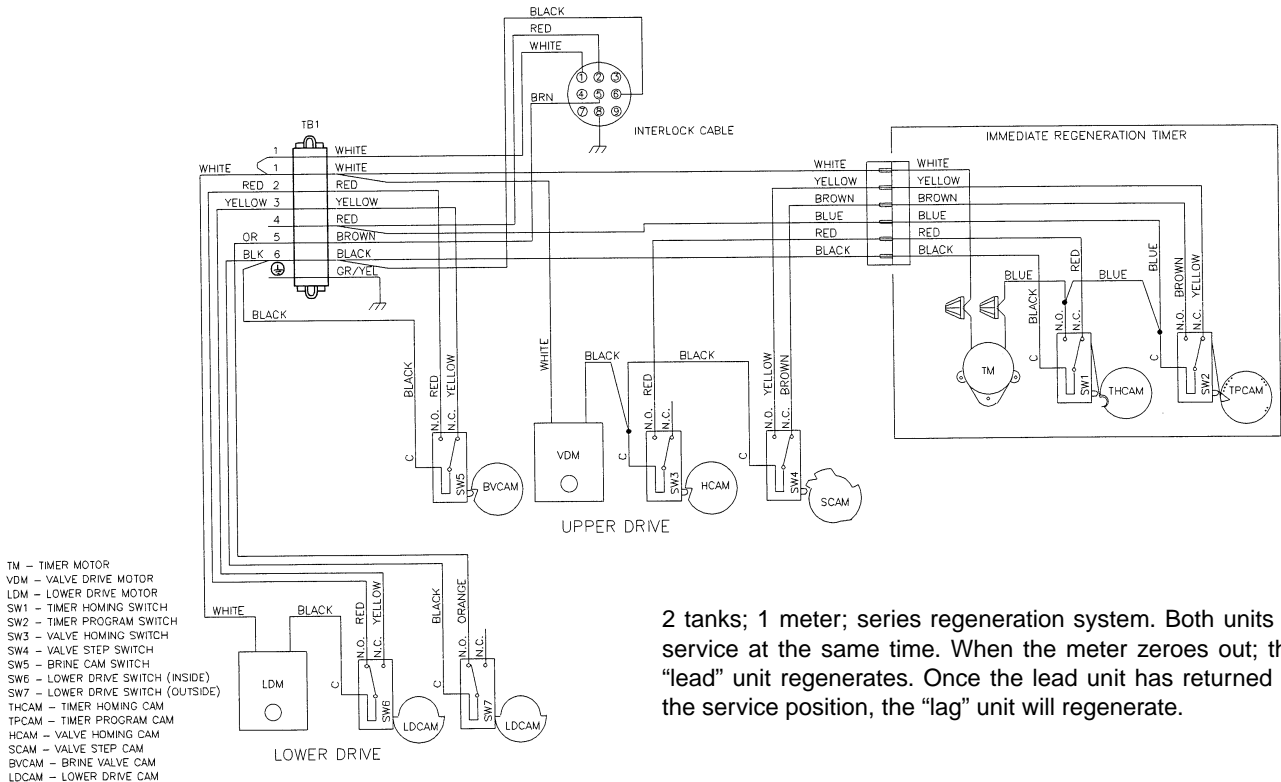
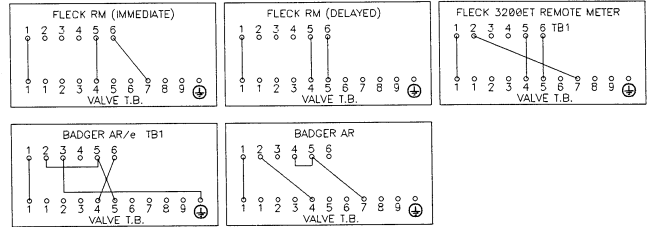

2 tanks; 1 meter; series regeneration system. Both units in service at the same time. When the meter zeroes out; the "lead" unit regenerates. Once the lead unit has returned to the service position, the "lag" unit will regenerate.

SYSTEM #7

Alternator Wiring Diagram

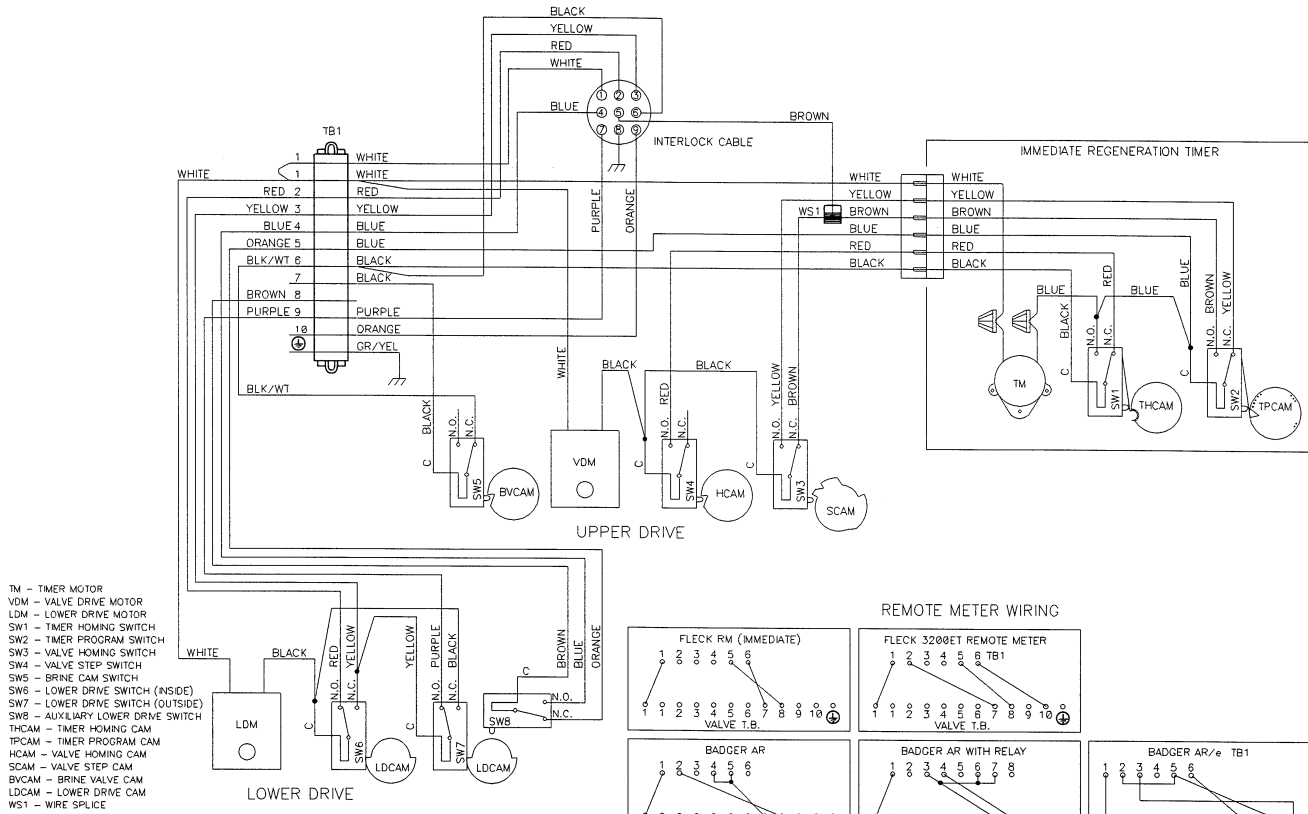

- TM - TIMER MOTOR
- VDM - VALVE DRIVE MOTOR
- LDM - LOWER DRIVE MOTOR
- SW1 - TIMER HOMING SWITCH
- SW2 - TIMER PROGRAM SWITCH
- SW3 - VALVE HOMING SWITCH
- SW4 - VALVE STEP SWITCH
- SW5 - BRINE CAM SWITCH
- SW6 - LOWER DRIVE SWITCH (INSIDE)
- SW7 - LOWER DRIVE SWITCH (OUTSIDE)
- SW8 - AUXILIARY LOWER DRIVE SWITCH
- THCAM - TIMER HOMING CAM
- TPCAM - TIMER PROGRAM CAM
- HCAM - VALVE HOMING CAM
- SCAM - VALVE STEP CAM
- BVCAM - BRINE VALVE CAM
- LDCAM - LOWER DRIVE CAM
- WS1 - WIRE SPLICE

NOTE:
TWO TANK SINGLE METER ALTERNATING REGENERATION.
ONLY ONE TANK IN SERVICE, THE OTHER IN REGENERATION OR STANDBY.

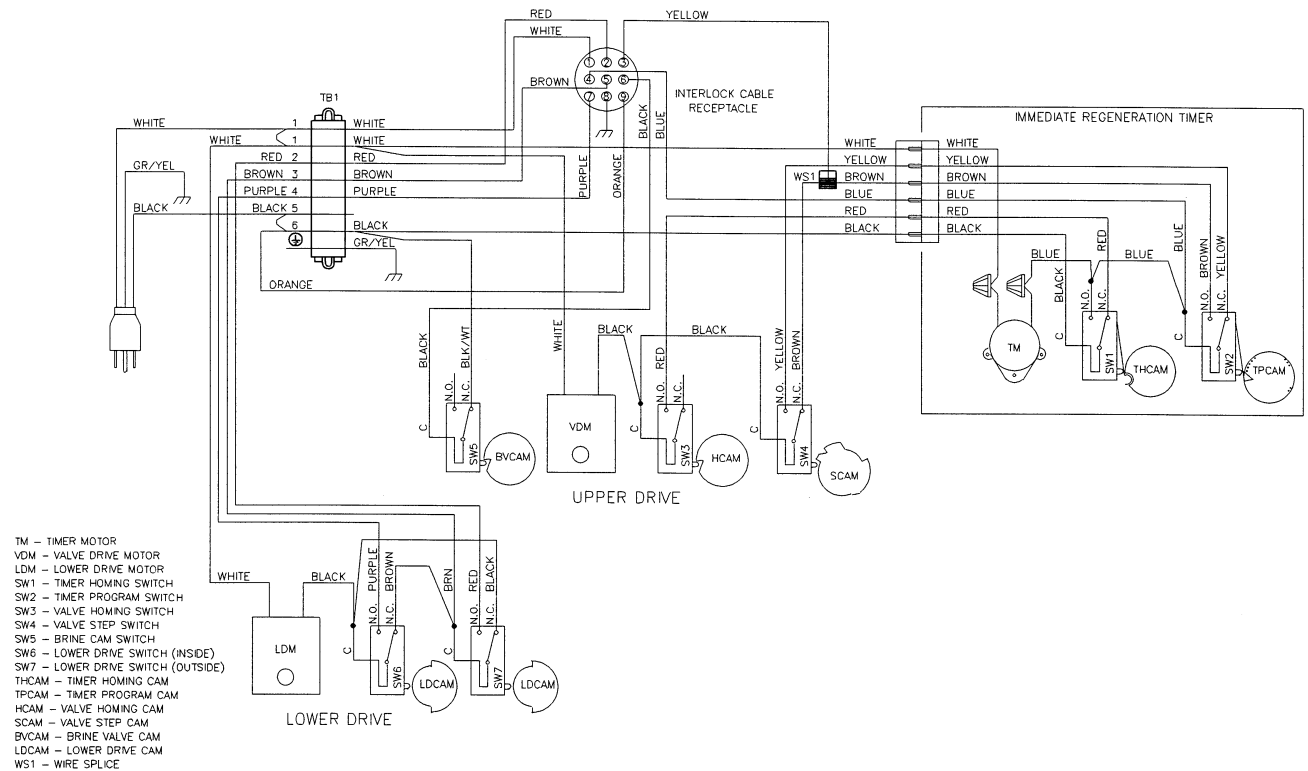
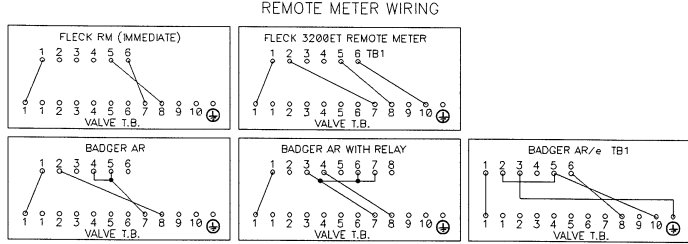

- TM - TIMER MOTOR
- VDM - VALVE DRIVE MOTOR
- LDM - LOWER DRIVE MOTOR
- SW1 - TIMER HOMING SWITCH
- SW2 - TIMER PROGRAM SWITCH
- SW3 - VALVE HOMING SWITCH
- SW4 - VALVE STEP SWITCH
- SW5 - BRINE CAM SWITCH
- SW6 - LOWER DRIVE SWITCH (INSIDE)
- SW7 - LOWER DRIVE SWITCH (OUTSIDE)
- THCAM - TIMER HOMING CAM
- TPCAM - TIMER PROGRAM CAM
- HCAM - VALVE HOMING CAM
- SCAM - VALVE STEP CAM
- BVCAM - BRINE VALVE CAM
- LDCAM - LOWER DRIVE CAM
- WS1 - WIRE SPLICE

SYSTEM #7 - MULTIVALVE

Alternator Wiring Diagram

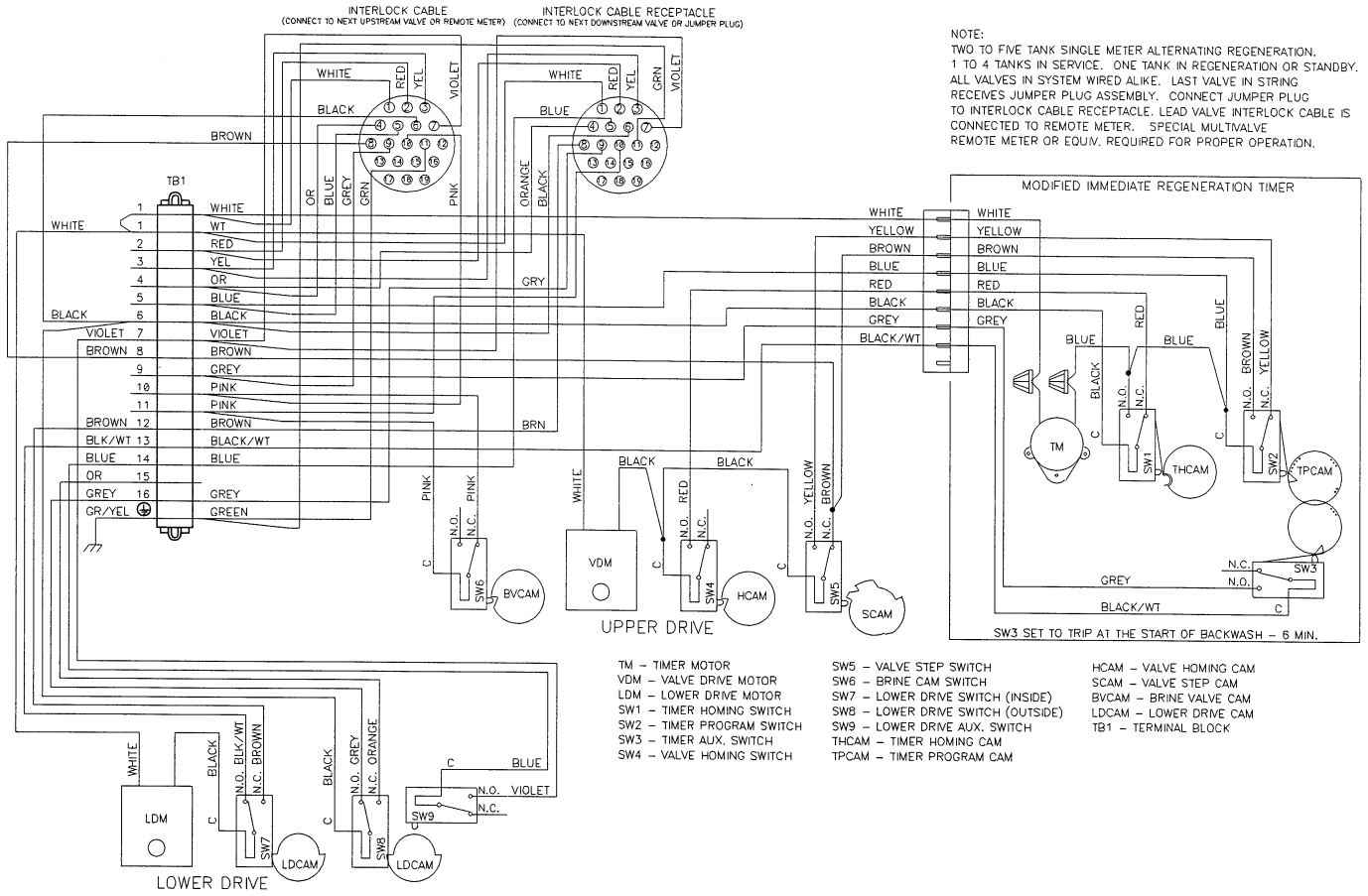

MODEL 2930

System #4 - Typical Single Tank Installation With Optional Meter

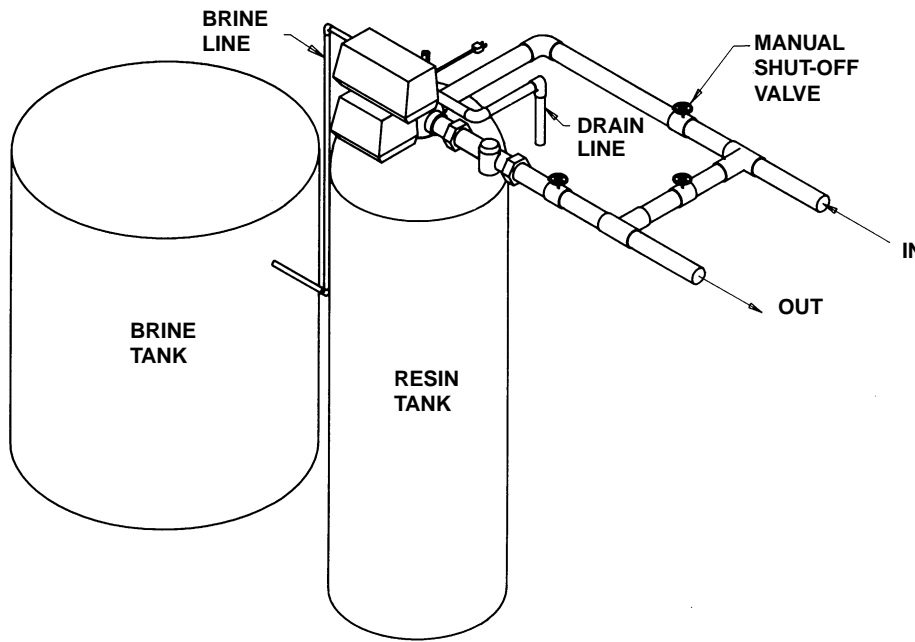

System #5 Interlock - Typical Twin Tank Installation With Optional Meter Interlock And No Hard Water Bypass

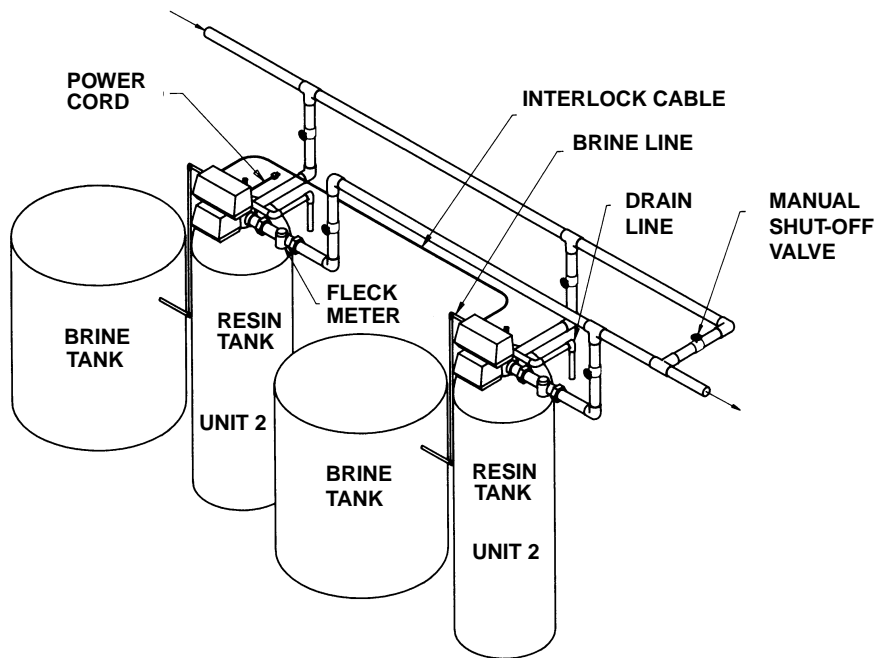

MODEL 2930

System #6 - Twin Series Regeneration

System #7 - Twin Alternator Installation

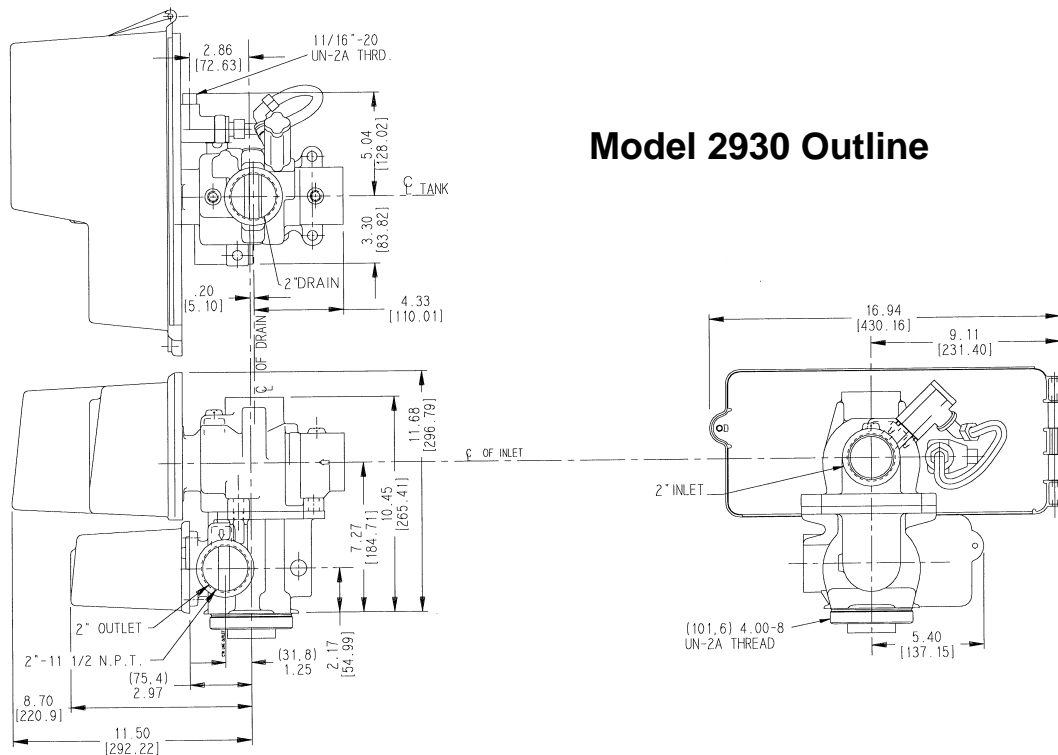
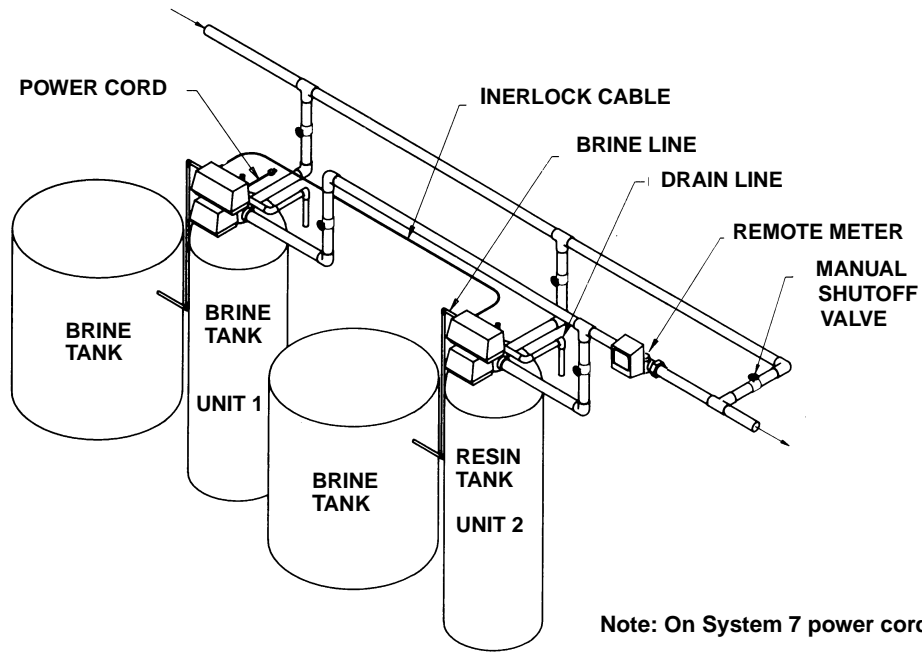

MODEL 2930

Service Assemblies

60034-790 1705 Brine Valve

For Illustration, See Page 16

- 1 10250 Brine Valve Spring Clip
- 1 12550 Quad Ring
- 1 13201 Quad Ring
- 1 14785-01 Flow Control Retainer
- 1 14790 Brine Valve Body
- 1 14792 Brine Valve End Plug
- 1 14795 Brine Valve Piston
- 1 40199 Brine Valve Stem
- 1 14798 Spacer
- 2 14811 Piston Seal
- 1 15310 Brine Valve Spring
- 1 40213 Stem Guide
- 1 16123 Nut 1/2"
- 1 16124 Ferrule 1/2"

60483-OXC 1705 Injector Assembly

For Illustration, See Page 12

- 1 10228 Injector Cap
- 1 10229 Injector Cover Gasket
- 1 17777-03 Injector Body
- 1 14801-x Injector Nozzle
- 1 14802-x Injector Throat
- 1 13771 O-Ring
- 2 14804 Screw
- 1 19925 Injector Body Gasket

60166 2930 Piston Assembly, Upper

For Illustration, See Page 12

- 1 14296 Quad Ring, -012
- 1 14922 O-Ring, -035
- 1 14754-01 End Plug
- 1 14818 Clip, Piston Rod
- 1 40203 Spacer, Endplug
- 1 40204 Piston, 2930
- 1 40205 Piston Rod, 2930/3130

60103 2900/2930 Piston Assembly, Hard Water By-Pass

For Illustration, See Page 12

- 1 14754-01 End Plug, 2930
- 1 14757 Piston, Hard Water By-Pass
- 1 14758 Piston Rod, 2930
- 1 14818 Ring, Piston Rod Snap
- 1 14922 O-Ring, -035
- 1 14926 Quad Ring, -012

60104 2900/2930 Piston Assembly, No Hard Water By-Pass

For Illustration, See Page 12

- 1 14752 Piston, No Hard Water By-Pass
- 1 14754-11 End Plug, 2930
No Hard Water By-Pass
- 1 14758 Piston Rod, 2930
- 1 14818 Ring, Piston Rod Snap
- 1 14922 O-Ring, -035
- 1 14926 Quad Ring, -012

60131 2930/3130/3150 Upper Seal and Spacer Kit

For Illustration, See Page 12

- 8 11720 Seal, Piston
- 2 10368 Spacer
- 5 10369 End Spacer, Noryl

60128 2900/2930 Lower Seal & Spacer Kit

For Illustration, See Page 12

- 2 10369 Spacer
- 4 11720 Seal, Piston 2930/3150
- 1 14753 Spacer

60050 -91 Drive Motor Assembly, 24V, STF

-92 Drive Motor Assembly, 115V, STF

-93 Drive Motor Assembly, 230V, STF

For Illustration, See Page 10

- 3 10218 MicroSwitch
- 2 14923 Screw #4 x 1 1/13
- 3 10302 Insulator
- 2 10338 Roll Pin 3/22 x 7/8
- 1 40190 -1156 ... Drive Motor 110V 50/60 Hz
-245 ... Drive Motor 24V 50/60 Hz
-2305 ... Drive Motor 230V 50/60 Hz
- 1 40202 Motor Bracket - Drive Side
- 5 10872 Screw #8 x 5/16
- 1 16430 Wire Harness
- 1 40175-01 Motor Lead Wire
- 1 40201 Motor Bracket BN Side
- 1 40198 Drive Cam - STF
- 1 12777 Brine Valve Cam
- 1 14784 Drive Bearing
- 1 10250 Retaining Ring
- 1 40197 Connecting Link
- 1 40349 Screw, Brine Deflection
- 1 40193 Screw, Ground
- 2 11805 Screw, Micro Switch Brine

(Continued)

MODEL 2930

Service Assemblies (Cont'd.)

60055 -51 2930 Lower Drive Assembly, 115V

-52 2930 Lower Drive Assembly, 230V

-53 2930 Lower Drive Assembly, 24V

For Illustration, See page 6

- 1..... 10218..... Micro Switch
- 1..... 10250..... Retaining Ring
- 1..... 10302..... Insulator, Limit Switch
- 4..... 10872..... Screw, Hex Washer 8-32 x 5/16
- 1..... 10876..... Wire, Red 12"
- 1..... 11381..... Pin, Roll 1/16 x 5/8 Lg
- 2..... 14203..... Screw, Rd Hd 4-40 x 9/16
- 1..... 14759..... Link, Piston Rod
- 1..... 14769..... Bracket, Motor
- 1..... 14772..... Motor, 110V/60 Hz
- 1..... 14775..... Cam, Drive
- 1..... 14784..... Bearing, Connecting Rod
- 1..... 15926..... Wire Harness, System 4
- 1..... 16103..... Insulator, Micro Switch

60393 2" Meter Assembly - Std. Range

For Parts Breakdown See Page 19

60394 2" Meter Assembly - Ext. Range

60620 2" Plastic Meter Assembly - Std. Range

60621 2" Plastic Meter Assembly - Ext. Range

For Parts Breakdown See Page 19

Notes
