

# Testomat<sup>®</sup> ECO

Microprocessor controlled analysis unit



Operating instructions

# Contents

|                                                       |          |                                                          |           |
|-------------------------------------------------------|----------|----------------------------------------------------------|-----------|
| <b>Introduction</b> .....                             | 1        | Function STOP .....                                      | 11        |
| <b>Short description</b> .....                        | 1        | Water meter .....                                        | 12        |
| <b>Reagents available for the Testomat® ECO</b> ..... | 1        | Interface .....                                          | 12        |
| <b>Notes for the user</b> .....                       | 2        | <b>Structure of the menu</b> .....                       | <b>12</b> |
| <b>Note about the operational reliability</b> .....   | 2        | Selection and input .....                                | 12        |
| <b>Safety Notes</b> .....                             | 2        | Start menu .....                                         | 12        |
| <b>Installation and commissioning</b> .....           | <b>3</b> | Selection .....                                          | 12        |
| Installation .....                                    | 3        | Input .....                                              | 12        |
| Electrical Connection .....                           | 3        | End menu .....                                           | 12        |
| Mains water supply .....                              | 3        | <b>Informations menu "i"</b> .....                       | <b>13</b> |
| Operation with small aerator .....                    | 4        | Structure of the "i" - menu .....                        | 13        |
| Water to drain .....                                  | 4        | Call .....                                               | 13        |
| Commissioning .....                                   | 4        | Operating values .....                                   | 13        |
| Installation diagram (Example) .....                  | 4        | Program values .....                                     | 13        |
| <b>General description</b> .....                      | <b>5</b> | <b>Program menu "M"</b> .....                            | <b>14</b> |
| Internal construction .....                           | 5        | Service I .....                                          | 14        |
| Terminal block identification .....                   | 6        | Input reagent .....                                      | 14        |
| Functions .....                                       | 6        | Manual operation .....                                   | 14        |
| Description of displays and operating features .....  | 7        | Language .....                                           | 14        |
| Display functions .....                               | 7        | Diagnosis .....                                          | 14        |
| Status of limit value displays .....                  | 7        | <b>Basic program</b> .....                               | <b>15</b> |
| Measured value display .....                          | 7        | Programming .....                                        | 15        |
| Limit value display .....                             | 7        | Structure of the <b>program menu "M"</b> .....           | 15        |
| Alarm message .....                                   | 7        | <b>Error messages / trouble shooting</b> .....           | <b>16</b> |
| Description of the relay outputs .....                | 8        | <b>Further information</b> .....                         | <b>17</b> |
| LV1 and LV2 limit value outputs .....                 | 8        | <b>Maintenance</b> .....                                 | <b>17</b> |
| Alarm fault message output .....                      | 8        | Description of maintenance work .....                    | 17        |
| Description of the signal inputs and output .....     | 9        | Cleaning the measuring chamber&sight-glass windows ..... | 17        |
| Stop external analysis stop .....                     | 9        | Cleaning the filter housing .....                        | 17        |
| IN water meter input .....                            | 9        | Note on care for the unit .....                          | 17        |
| OUT interface output .....                            | 9        | Spare parts list Testomat® ECO .....                     | 18        |
| <b>Function characteristics</b> .....                 | <b>9</b> | <b>Technical appendix</b> .....                          | <b>19</b> |
| Mode of operation .....                               | 9        | Block diagram "Testomat® ECO" .....                      | 19        |
| Analysis cycle .....                                  | 10       | Technical data .....                                     | 19        |
| Displayed unit .....                                  | 10       |                                                          |           |
| Type of reagent .....                                 | 10       |                                                          |           |
| Setting the timer .....                               | 10       |                                                          |           |
| Flush / Interval pause .....                          | 10       |                                                          |           |
| Monitoring of limit value .....                       | 10       |                                                          |           |
| Hysteresis .....                                      | 11       |                                                          |           |
| Logic functions .....                                 | 11       |                                                          |           |
| BOB-operation .....                                   | 11       |                                                          |           |

## Introduction

This operating instruction describes installation, operation and programming of the analysis unit Testomat® ECO. We recommend that, whilst familiarising yourself with the operation of the unit aided by this manual, you have immediate access to the unit in order to perform the functions and combinations as described. As certain functions are interrelated, it is advisable to follow the instructions in the given order.

Should problems or questions arise which are not described in this manual and/or cannot be solved, our customer service is always at your disposal.

Try to identify the problem as accurately as possible and record the conditions under which it has occurred. This will enable us to offer you swift effective assistance.

### Symbols and abbreviations used in these instructions:

 Note for the user

"STANDBY" = STANDBY lamp is "ON"



Important to observe / warning note

"M" = Press menu key M

✓ Tip: Helpful hint

→ SERVICE → MANUAL OPERATION → FLUSH = Sequence in a menu selection

### Short description

The Testomat® ECO is used for the automatic measuring and monitoring of the total water hardness.

The parameter to be measured is determined by the choice of the reagent and by the corresponding user program.

### Reagents available for the Testomat® ECO

The various measuring parameters and ranges are determined by the choice of the reagents. The table gives a summary of the different possibilities.

|      |                                       | Parameter/Type of reagent |                           |                           |                           |
|------|---------------------------------------|---------------------------|---------------------------|---------------------------|---------------------------|
|      |                                       | Water hardness<br>TH 2005 | Water hardness<br>TH 2025 | Water hardness<br>TH 2100 | Water hardness<br>TH 2250 |
| Unit | °dH<br>(Resolution)                   | 0.05 - 0.50<br>(0.01)     | 0.25 - 2.50<br>(0.05)     | 1.0 - 10.0<br>(0.2)       | 2.5 - 25.0<br>(0.2)       |
|      | °f<br>(Resolution)                    | 0.09 - 0.89<br>(0.02)     | 0.45 - 4.48<br>(0.1)      | 1.79 - 17.9<br>(0.4)      | 4.48 - 44.8<br>(0.4)      |
|      | ppm CaCO <sub>3</sub><br>(Resolution) | 0.89 - 8.93<br>(0.2)      | 4.47 - 44.7<br>(0.9)      | 17.9 - 179<br>(3.8)       | 44.7 - 447<br>(3.8)       |
|      | mmol/l<br>(Resolution)                | 0.01 - 0.09<br>(0.01)     | 0.04 - 0.45<br>(0.01)     | 0.18 - 1.79<br>(0.04)     | 0.45 - 4.48<br>(0.04)     |

 **A consistently reliable result can be guaranteed by the TESTOMAT® ECO only with the use of original HEYL Testomat® 2000 reagents ! Failure or problems which are caused by the use of different indicators are not covered by the warranty or refund services.**

When monitoring residual/total hardness, larger quantities of heavy-metal ions in the softened water can affect the colour reaction, especially iron above 0.5 mg/l, copper above 0.1 mg/l and aluminium above 0.1 mg/l (brownish-red colour indication). The measuring is possible in a range of pH 4-10.5.



At a concentration of more than 100 mg/l of CO<sub>2</sub> (carbon dioxide) in the water, the excess carbon dioxide must be removed by installing a Type R aerator in the feed water line to the TESTOMAT® ECO unit. When using the TESTOMAT® ECO for monitoring a de-carbonisation installation (weakly acidic cation exchanger) without its own irrigator, a small scale irrigator must always be installed upstream of the device.

Concentration values of these ingredients can be determined safely and simply with our TESTOVAL colorimetric test comparators.

## Notes for the user

- **Repeated switching 'on' and 'off':**

Wait at least for 5 seconds before you switch the unit repeatedly 'on' or 'off' at the main switch.

- **Observation of the environmental conditions:**

In order to guarantee a reliable operation, the unit must only be used under the environmental conditions described in the technical data. Protect the controller against excessive humidity, condensation and water-splash.

- **Safety seal:**

The original seals attached during manufacture (e.g. EPROM labels) must not be broken, otherwise all warranty rights are lost.

- **Malfunction / repair of defective units:**

The repair of a defective unit is only possible when the unit is dismantled and returned to us with a description of the fault. This in no way affects the guarantee rights. In addition, please inform your supplier of the reagent type used and of the quality of treated water measured.

Before you return the unit for repair, remove the reagent bottle and ensure that the measuring chamber is flushed out and empty.

- **Electrical load capacity**

The maximum electrical load capacity of the relay outputs and the total power rating must not be exceeded.

- **Operate the Testomat® ECO strictly in accordance with the manufacturer's instructions.**

- **Environmental protection regulations**

Please observe the environmental protection regulations and collect any unused reagent for safe disposal in accordance with local statutory requirements.

## Operational Checks

Careful handling of the unit increases both the operational reliability and the service life! Therefore the following visual inspection should be carried out at regular intervals.

- Are the hose connections with the dosing pump free of leaks?
- Is there any air inside the dosing hoses?
- Are all the water connections free of leaks?
- Are the doors of the unit properly closed?
- Is the unit unduly contaminated with dirt?

## Maintenance and servicing notes

(see page 17)

## Safety notes

- The unit must be installed and operated in compliance with the relevant standards (e. g. DIN, VDE, UVV).
- Some functions (e. g. the manual analysis) allow the direct manipulation of the installation without locking or monitoring. These functions may only be used by trained staff and for this reason they are only accessible after a pass word has been entered.
- If you observe the unit malfunctioning, switch it off immediately. Then shut off the water supply and contact your supplier.
- Do not attempt to repair the unit yourself (loss of warranty rights); instead always get in touch with the authorised service staff. This is the only way a reliable and safe operation of the unit can be ensured.
- After a protective circuit (fuse) has tripped, first of all, attempt to correct the cause of the malfunctioning (e. g. replace the solenoid valve) before reactivating the protective circuit. Frequent tripping is always due to a fault which, in certain circumstances, may also cause damage to the unit.
- Observe the safety notes about working with reagents, chemicals and cleaning agents.

 Ignoring these notes can result in damage to the unit as well as the installation and may result in a loss of warranty rights.

# Installation and commissioning

**Installation and commissioning must be undertaken only by authorised technicians!**

## Installation

**The unit should be fixed vertically!**

**Avoid tension of the housing.**

The unit doors swing to the left when they are opened. Please ensure that there is sufficient space for opening them. In this way, you facilitate the electrical installation and later maintenance and service work.

## Electrical connection

 Check supply voltage on the rating plate!

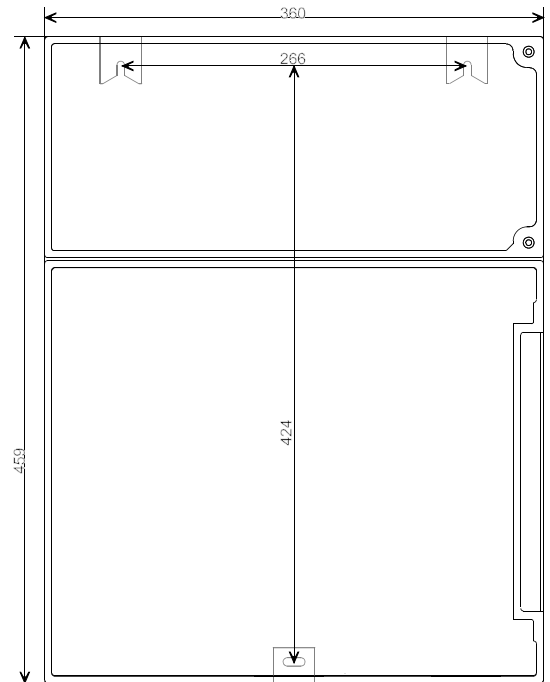

Dimensioned sketch

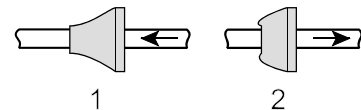

## Basic requirements

The external cables (e.g. water meter, interface) should be kept as short as possible and clear of power cables.

## Connection

Loosen both fastening screws and open the upper door. Pierce the required rubber cable glands with a screwdriver and insert the cable (1). Then pull back the cable until the bush (2) has been turned over. Ensure that the leads are held securely in the terminals then close the upper door after the installation is completed using the two fastening screws.

## Mains water supply

 The temperature of the sample water must be between 10 °C and 40 °C. Higher water temperatures can lead to damage to all parts coming into contact with water (e. g. filter housing, measuring chamber)! Lower water temperatures can cause misting on the sight-glass windows.

 In the event of higher temperatures, the Type KCN cooler must be installed in the branch line of the TESTOMAT® ECO.

 Hot water can lead to scalding!

The branch line should be positioned as close as possible to the outlet from the water softening plant. The branch line to the Testomat® ECO with a hand-operated shut-off valve must be kept as short as possible and not longer than a maximum of 5 meters. It is important that the branch line connection is taken vertically from the top of the main soft water line in order to prevent dirt particles from entering into the measuring chamber.

## Plug connector

The unit is equipped as a standard with a plug connector for opaque plastic hoses 6/4 x 1 (external diameter 6 mm/ internal diameter 4 mm).

## Quick-acting coupling (accessory: Optional adapter for water inlet, Order no. 40123)

 Only with installed regulator / filter housing (optional available)

When fabric reinforced pressure hoses (e.g. for existing installations) are used, please replace the plug connector at the controller and filter housing with a plug for the quick-acting coupling (not included with the delivery).

### Operation with small aerator

If the sample water to the TESTOMAT® ECO contains more than 100 mg/l of CO<sub>2</sub>, it will be necessary to install a Type R small aerator. The aerator must be installed at least 3 m above the TESTOMAT® ECO. When operating with the small aerator extract the valve body out of the regulator/filter housing (see page 17). We recommend a booster pump for a lower operating pressure (Item No. 270410).

### Water to drain

The feed water flows through the measuring chamber then, via the outlet pipe, to the drain (hose connection internal diameter 14 mm). Make sure, by using a funnel for example, that the water can run freely to drain and cannot back-up into the measuring chamber. A hose impervious to light should also be used for the drain pipe (to discourage algae formation).

### Commissioning

1. A full reagent bottle must be connected before commissioning and switching on. Attach the vacuum connection onto the reagent bottle using the union nut.
2. Switch the unit 'on' and press the "STANDBY" key. In this mode, an analysis is prevented from being carried out before a correct program has been entered which could possibly result in an error or alarm message.
3. Then bleed the dosing pump and the capillary by repeatedly pressing the "Manual" key on the dosing pump. Ensure all air is removed from the tubing ! (If necessary tighten up the connections.)
4. Program the unit as applicable to your requirements, e. g.:

|                       |                     |
|-----------------------|---------------------|
| - Mode of Operation   | - Type of reagent   |
| - Displayed unit      | - Limit values      |
| - Flush time/interval | - Analysis interval |

For a description of programming see from page 12.

5. Then remove all air from the water supply side of the unit by manual flushing.  
"M" → SERVICE → MANUAL OPERATION → FLUSH ("ENTER" press repeatedly).  
You should continue flushing until no bubbles can be seen in either the measuring chamber or the filter housing.
6. Check all connections for tightness.
7. By pressing the "Manual" key you carry out the first analysis.

### Installation diagram (Example):

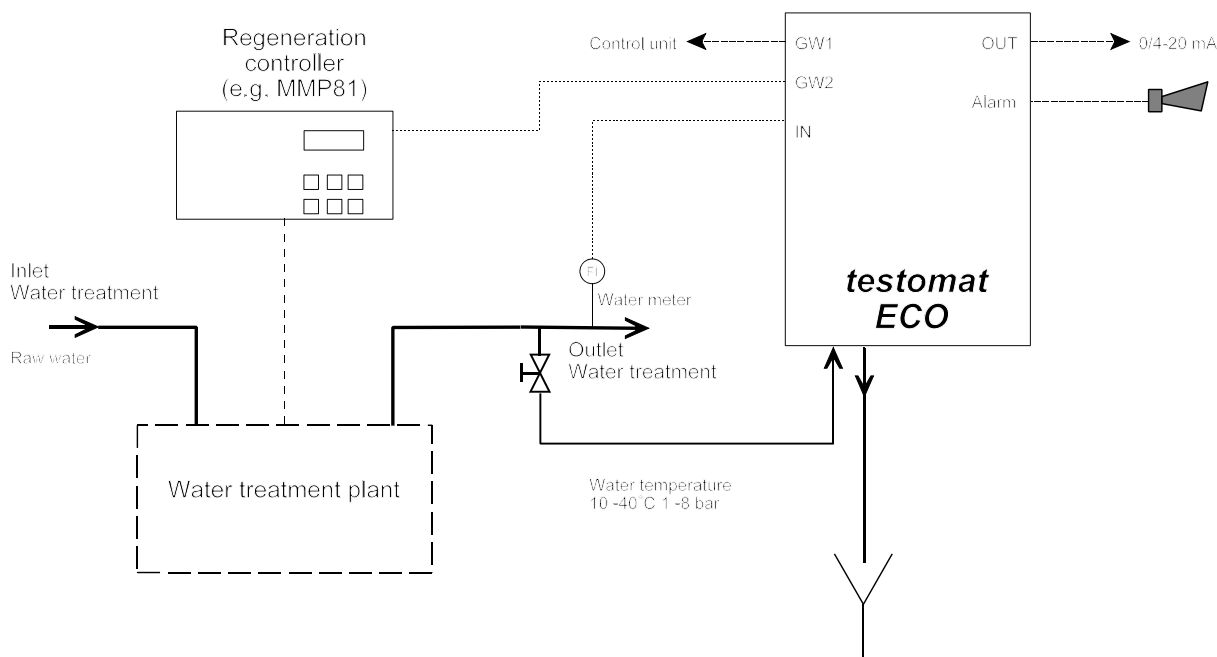

# General description

## Internal construction

Terminal block for inputs  
 Stop, IN2 (water meter) and output OUT

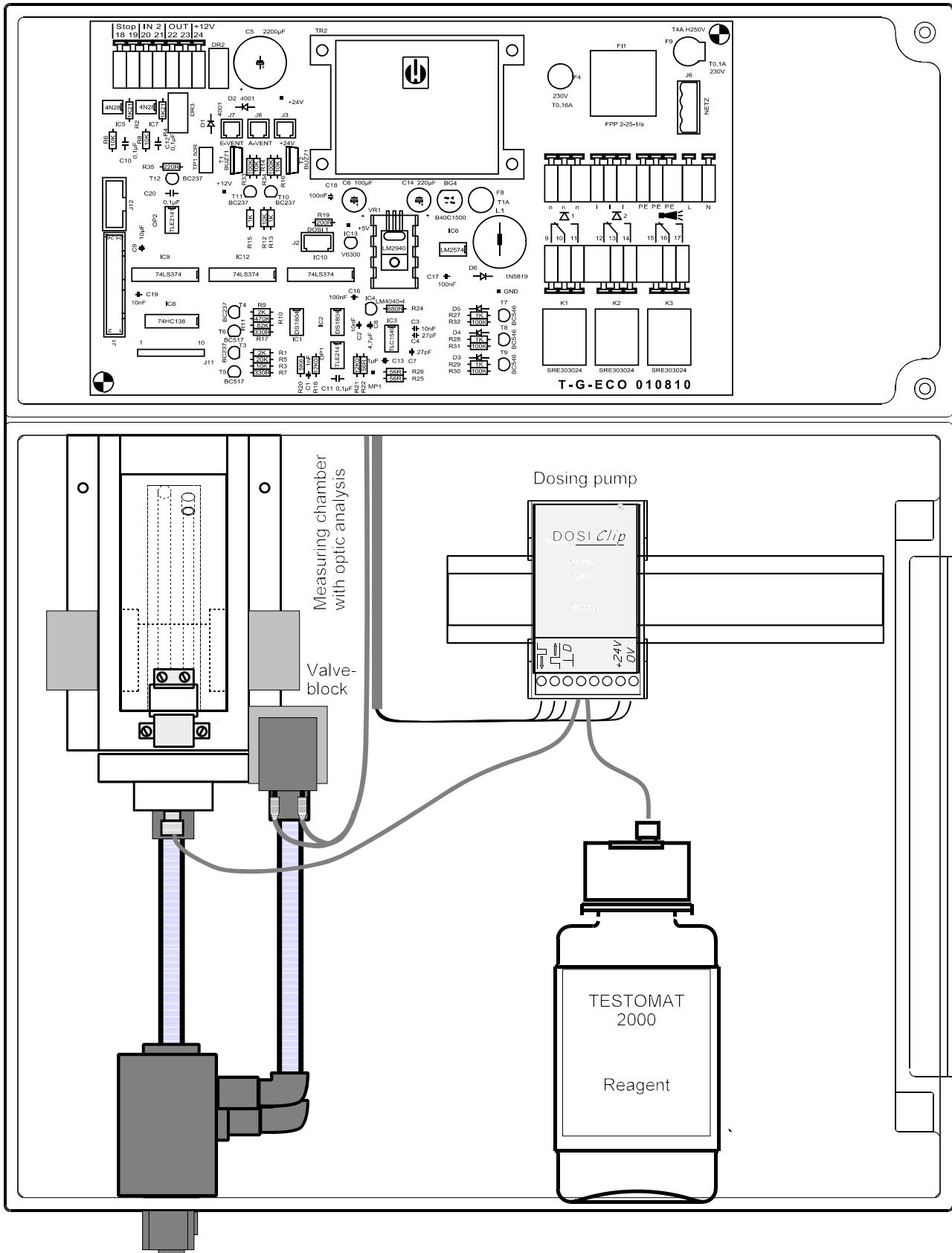

Terminal block for mains connection and relay outputs  
 Power-switch

Mains water supply:  
 Inlet and outlet with primary filter and pressure regulator

# Terminal block identification

## Functions

IN = Input, OUT = Output

| Nr.            | Terminal       | Type | Function                                                                                                        | Note                                                                                              |
|----------------|----------------|------|-----------------------------------------------------------------------------------------------------------------|---------------------------------------------------------------------------------------------------|
| -              | PE             | IN   | Mains - Protective earth (5x)                                                                                   |                                                                                                   |
| 1<br>2         | L<br>N         | IN   | Mains, L = Live<br>Mains, N = Neutral                                                                           | Mains - input<br>230 - 240 V AC                                                                   |
| 3-5<br>6-8     | n<br>l         | OUT  | Neutral, switched (8 x)<br>Live, switched (8 x)                                                                 | Mains voltage, max. 4 A                                                                           |
| 9<br>10<br>11  | LV1            | OUT  | Limit value output 1 - Normally closed<br>Limit value output 1 - Common<br>Limit value output 1 - Normally open | Volt-free relay output<br>max. load 240 V AC, 4 A                                                 |
| 12<br>13<br>14 | LV2            | OUT  | Limit value output 2 - Normally closed<br>Limit value output 2 - Common<br>Limit value output 2 - Normally open | Volt-free relay output<br>max. load 240 V AC, 4 A                                                 |
| 15<br>16<br>17 | Alarm          | OUT  | Fault message - Normally closed<br>Fault message - Common<br>Fault message - Normally open                      | Volt-free relay output<br>max. load 240 V AC, 4 A                                                 |
| 18<br>19       | Stop<br>⊥      | IN   | External analysis stop<br>Common earth for inputs                                                               | Only volt-free normally<br>open/normally closed contact!                                          |
| 20<br>21       | IN<br>⊥        | IN   | Water meter input<br>Common earth for inputs                                                                    | Only for volt-free normally<br>open/normally closed contact/ Note<br>technical data of turbine!   |
| 22<br>23       | OUT +<br>OUT - | OUT  | 0/4 - 20 mA                                                                                                     | Potential output !<br>22 = + 0/4 - 20 mA, 23 = -                                                  |
| 24             | +              | OUT  | +12V for Hall-Sensor (turbine)                                                                                  | Note technical data of turbine!<br>Max. power input of sensor is not<br>allowed to exceed 20 mA ! |

Terminal block for inputs  
Stop, IN2 and output OUT

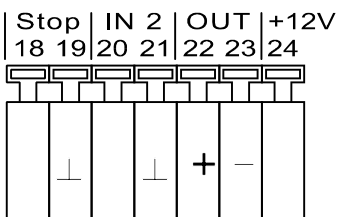

Terminal block for mains connection and relay outputs

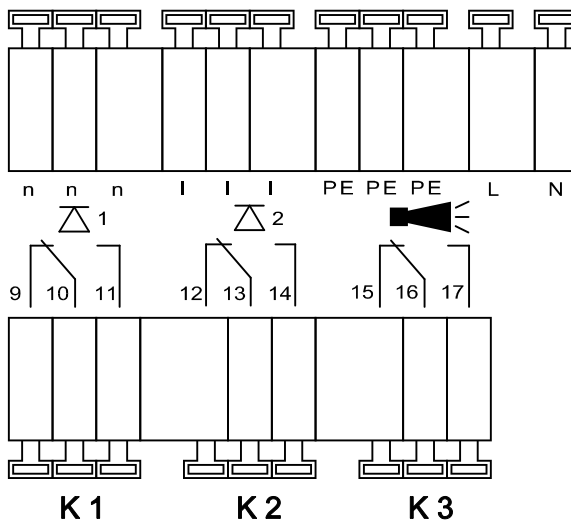

## Description of displays and operating features

### (1) Power switch

The 'ON'/OFF' switch is located on the right-hand side panel.

### (2) Unit fuse (inside the unit)

Protects outputs against overload and short circuit.

### 3 Status of limit value displays

Displays the status of the limit values LV1 (1) and LV2 (2).

### 4 Text display

Displays the current analysis, all important status results and programming data in a 2-line LC-Display.

### 5 Alarm

Displays a function fault.

### 6 Analysis message

Displays current analysis.

### 7 Programming keys (Cursorblock with ENTER)

These keys are used to enter all values and programming data.

#### Function keys:

8 "Manual" = manual start of an analysis

9 STANDBY = manual analysis stop/standby

## Display functions

### Status of limit value displays $\Delta$ 1 and $\Delta$ 2

The display signals the status of the limit values.

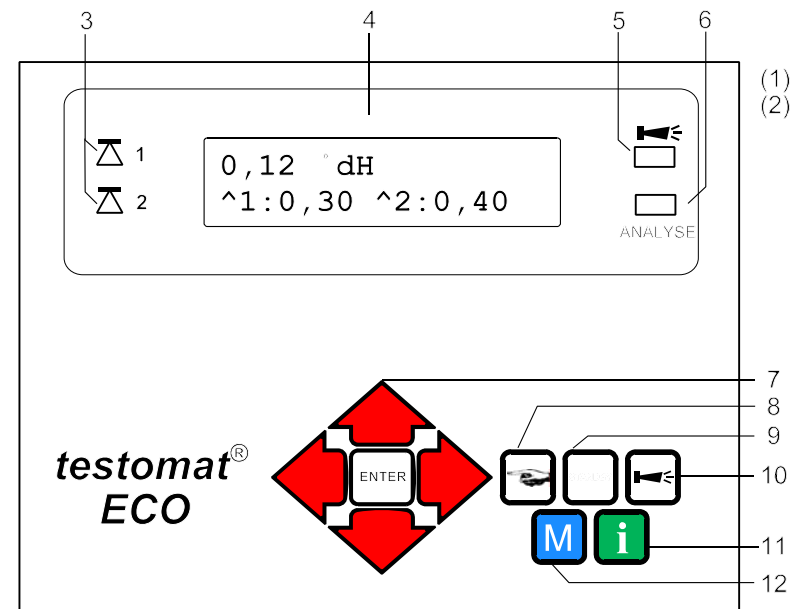

10 "Alarm" = cancels alarm message

### 11 i-key

Call-up all unit information (see i-menu).

### 12 M-key

Call-up the programming menu for user and specific unit settings (see M-menu).

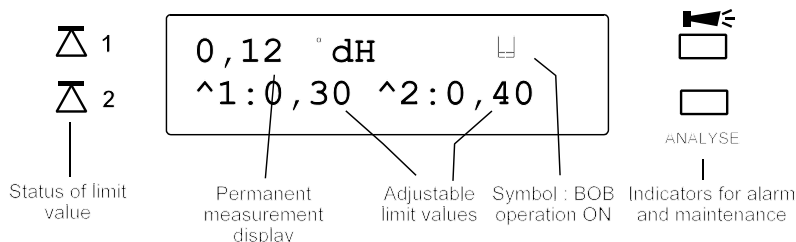

1: The red display lamp lights up if the limit value 1 is reached or exceeded.

Lights up green if the measured value falls below the set limit value.

2: The red display lamp lights up if the limit value 2 is reached or exceeded.

Lights up green if the measured value falls below the set limit value.

### Status and measured value display

In continuous operation the current measured value is shown in the upper line.

When the measured value falls below the measuring range "<" is displayed: e. g. < 0.05 °dH

When the measured value exceeds the measuring range ">" is displayed: e. g. > 10.0 °dH

When the analysis interval is stopped in operation (Analysis Stop), "STANDBY" and measured value are displayed alternately.

The sign "  $\square$  " in the line of measured value symbolises active BOB - operation.

### Limit value displays

The adjustable limit values are shown in the bottom display line.

### Alarm message

Display of present error messages (red)

⚠ Error messages are displayed alternately with the normal display text and can only be deleted by cancellation and correction of the fault.

## Description of the relay outputs

### LV1 and LV2 Limit value outputs

For reporting that a limit value has been exceeded, two volt-free relay contacts are available. For both contacts the limit values, the hysteresis and the function can be independently programmed:

| Function                                                         | Type of contact               | Action                                                                                                                                                                                        |
|------------------------------------------------------------------|-------------------------------|-----------------------------------------------------------------------------------------------------------------------------------------------------------------------------------------------|
| <b>LV1</b><br>– active at limit value in excess of limit value 1 | volt-free change-over contact | programmable:<br>– Continuous contact<br>– Impulse (1 - 99 seconds/minutes)<br>– Interval (1 - 99 seconds/minutes)<br>– Two -step regulator<br>– Hysteresis (1, 2 or 3 limit value in excess) |
| <b>LV2</b><br>– active at limit value in excess of limit value 2 | volt-free change-over contact | programmable:<br>– Continuous contact<br>– Impulse (1 - 99 seconds/minutes)<br>– Interval (1 - 99 seconds/minutes)<br>– Hysteresis (1, 2 or 3 limit value in excess)                          |

Menu values:

- "M" → BASIC PROGRAM → PROGRAM VALUES → LIMIT VALUES
- "M" → BASIC PROGRAM → PROGRAM VALUES → FUNCTION LV1
- "M" → BASIC PROGRAM → PROGRAM VALUES → FUNCTION LV2
- "M" → BASIC PROGRAM → PROGRAM VALUES → HYSTERISIS LV1
- "M" → BASIC PROGRAM → PROGRAM VALUES → HYSTERISIS LV2

### Alarm Fault message

The "Alarm" output is a volt-free change-over relay contact. During trouble-free operation the contact between the terminals 16 – 17 is closed and the one between terminals 15 – 16 is open. When the voltage fails or the alarm is activated, the contact between terminals 15 – 16 is closed and the one between 16 – 17 is open.

T

The unit is equipped with a range of monitoring functions.

- The "Alarm" output remains activated (with terminals 15 – 16 closed) as long as the fault persists.
- The red LED "Alarm" and the text on the display indicate a fault.
- The error signal at the "Alarm" output is deleted by cancelling the fault with the "Horn" key.
- An error message can only be deleted after the fault has been corrected.
- **Exception:** "Reagent low level", this message is confirmed in the M-menu by entering in the new reagent level.

The following faults activate the "Alarm" output and are displayed:

- |                                |                           |
|--------------------------------|---------------------------|
| Low-water pressure             | Reagent low level         |
| Function fault optics          | Measuring fault dirtiness |
| Measuring fault analysis       | Measuring fault turbid    |
| Function fault dosing pump     | Measuring range exceeded  |
| Function fault outlet to drain |                           |

Error messages are described on page 16.

For a more detailed description of the programming refer to page 14. For general maintenance refer to page 17.

## Description of the signal inputs and output

☞ Connect the signal inputs "Stop", "IN" with **volt-free** contacts only !

### Stop external analysis stop

| Function                                                                                              | Type of contact                                                | Test time | Action                                                                                    |
|-------------------------------------------------------------------------------------------------------|----------------------------------------------------------------|-----------|-------------------------------------------------------------------------------------------|
| <b>Stop</b><br>– external analysis stop<br>(e. g. via flow controller or from the process controller) | programmable<br>normally<br>closed/normally<br>open volt-free! | none      | – So long as the contact at the input is 'open' or 'closed', no analyses are carried out. |
| <b>IN</b><br>– Water meter input                                                                      | normally closed/<br>normally open<br>volt-free!<br>or turbine  | none      | – Quantity recording to start an analysis                                                 |

"M" → BASIC PROGRAM → PROGRAM VALUES → INPUT STOP

"M" → BASIC PROGRAM → PROGRAM VALUES → WATER METER

### Installation example for the water meter

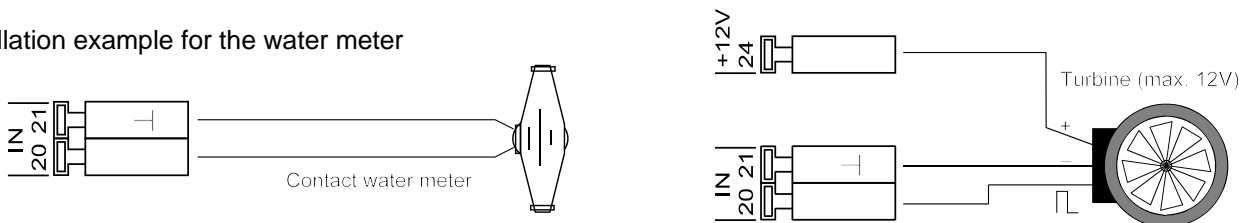

### OUT Interface output

| Function                 | Terminal             | Test time | Action                                     |
|--------------------------|----------------------|-----------|--------------------------------------------|
| power interface 0/4-20mA | max. load<br>350 Ohm | -         | programmable<br>– 0 - 20 mA<br>– 4 - 20 mA |

"M" → BASIC PROGRAM → PROGRAM VALUES → 0/4-20mA

## Function characteristics

### Mode of operation (Analysis controller)

1. **Time control:** Internal triggering by a timer. The shortest interval = 0 minutes between analyses, longest interval = 99 minutes.  
(see page 10, interval periods)

☞ The analysis interval is determined by the duration of the set flush times the programmed (interval) and the duration of the analysis. The analysis duration is a **direct** function of the value to be measured.

2. **Quantity control:** Triggered by the water meter.

Minimum interval = 1 litre, maximum interval = 9999 litres.

After the programmed water quantity is measured, the analysis is carried out. Prior to the analysis, the capillary and the measuring chamber are flushed (observe the programmed flush times).

☞ The current analysis interval can be interrupted by making contact at the "Stop" input.

## Analysis cycle (Example with schematic cycle diagram)

- 1 Flush branch line and measuring chamber (note flush time of the sampling line)
- 2 Fill measuring chamber
- 3, 4 Check the sample for dirtiness, dosing reagent (stirring mechanism is "ON")
- 5 Evaluate and display reaction
- 6 Drain measuring chamber
- 7 Pause period up to the next analysis (time or quantity analysis interval),  $T_p$ .  
 $T_1$  = total analysis interval, ch = measuring chamber

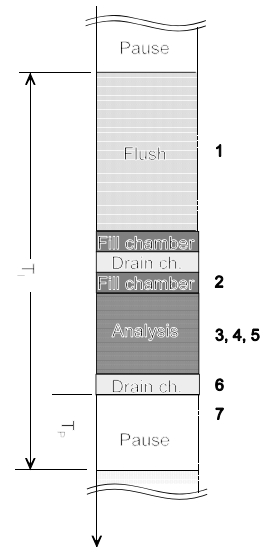

## Displayed unit

Programmed hardness unit is displayed. You have the choice of °dH, °f, ppm CaCO<sub>3</sub> and mmol/l. The unit entered will now be displayed as programmed.

## Type of reagent

Select the reagent type you are utilising in the unit, e. g. reagent TH 2005 means 8.93 ppm CaCO<sub>3</sub> upper limit of the measuring range and 0.89 ppm CaCO<sub>3</sub> lower.

## Setting the timer

### Flush

In order to ensure the analysed sample represents the current value, the sampling tube must be sufficiently well flushed taking its length into consideration. After the installation has been out of operation for a longer period or in the case of long analysis intervals, it is sensible to select a flushing time in excess of 60 seconds. Flush is initiated by simultaneously opening the Testomat® ECO's inlet and the outlet valves.

 The analysis interval directly depends on the programmed flush time. If a flush time of, for example, 90 seconds is set, the analysis interval itself cannot be shorter than 90 seconds.

**Example:** For 3 bar pressure, a connection longer than 5 m, an internal tube diameter of 4 mm, and a minimal internal flushing time of 10 seconds is required to ensure a valid sample is taken from the sampling tube. The quantity of flush water for an internal flush of 1 minute is 0.5 litre.

### Interval pause

In the case of timed triggering of the analysis, the interval between two analyses (plus flush time) is determined by the interval pause. The shortest interval can be 0 minute. In this case, the analyses are carried out continuously. The longest interval is 99 minutes.

## Monitoring of limit value

Two outputs for the limit value are available for monitoring. You can program the limit value on a continuous scale. The range for the limit value depends on the reagent type used and on the programmed unit. The functions of these outputs can be programmed independently from each other.

When the limit value **LV1** is exceeded, limit value control display lights up **LV1 RED** and the relay output **LV1** reacts as programmed in the switch function. As long as this limit value is not exceeded, the display lights up **GREEN**. The unit operates in the same way for the limit value **LV2**.

## Hysteresis

Each limit value output reacts only after the 1<sup>st</sup>, 2<sup>nd</sup> or 3<sup>rd</sup> bad analysis result has been detected (suppression of the first or the second measured value).

This increases the reliability during the evaluation of the analysis e. g. after the measuring point has been switched over or if the sampling line has possibly not been flushed sufficiently. The hystereses of the two outputs LV1 and LV2 can be set independently from each other.

Operation: With a hysteresis of 2 a further analysis is carried out immediately after the limit value has been exceeded. Only if the limit value of this analysis is exceeded again, the corresponding output is energised. If you have set a hysteresis of 3, the corresponding output reacts only after the limit value has been exceeded for the 3<sup>rd</sup> time in succession.

## Logic functions of the limit value outputs LV1 and LV2

### Logic function 0, *Duration*

Output relay LV1 or LV2 pulls up when the measured value rises above limit value LV1 or LV2. If the measured value falls below the limit value LV1 or LV2 the relevant relay drops out again.

### Logic function 1, *Impulse*

If the measured value rises above limit value LV1 or LV2, the relevant output pulls up for a set time t. Independent of the time taken for the limit value to rise above the set limit, the relevant output always remains in the "ON" position for the set time.

### Logic function 2, *Interval*

If the measured value rises above one limit value, the relevant output pulls up at intervals with the time set. (Impulse/Pause)

### Logic function 3, *Two-point*

If the upper limit value LV1 is exceeded, the output relay LV1 pulls up. If the lower limit value LV2 falls below the set limit, output relay LV1 drops out.

The output relay LV2 pulls up according to the programmed logic function.

☞ This function is possible only if different values are selected for LV1 and LV2. For example for LV1 = 0.2° dH and for LV2 = 0.1° dH.

## BOB-Operation (BOB = Operation without constant supervision)

The Testomat ECO conforms to the German TRD 604 safety standard for monitoring of water hardness associated with steam boiler installations, when operation without constant supervision is a relevant safety feature (= **Betrieb Ohne ständige Beaufsichtigung** = BOB -operation).

When the BOB function is programmed, the unit constantly monitors the reagent quantity available. For calculating the reagent consumption per analysis, a measured value of 1.48 ppm CaCO<sub>3</sub> (0.015 mmol/l alkaline earth ions) is used. An alarm is activated if the residual reagent quantity is insufficient for the set BOB period of 72 hours.

BOB on: Continuous monitoring of the residual reagent quantity. *ALARM* message when the available quantity falls below the minimum quantity for the BOB period: "Alarm" flashes, the Alarm output is energised.

BOB off: Without BOB function: the residual reagent quantity is only monitored for the minimum quantity (10 % level).

Example: BOB-Duration = 72 Hours                      Number of analyses per hour = 10  
Necessary quantity of reagent for 72 h = 72 h x 10 Analysis/h x (3 x 30) µl/Analysis = **64.8 ml**.  
(That corresponds to approx. 13% of a full level bottle)

## Funktion STOP

The active analysis interval can be interrupted through contact with the **stop** input. The active condition has to be programmed according to your requirements.

## Water meter

For quantity dependent analysis triggering it is necessary to connect a water meter to the IN2 input. Program the corresponding water meter rating under menu item "WATER METER", or enter the impulse number of the turbine water meter.

## Interfaces

### Interface 0/4-20 mA

Another possibility for monitoring the analysis is the connection of a recorder. For this purpose the unit is equipped with a programmable current output.

Standard values of 0 - 20 mA and 4 - 20 mA can be selected.

👉 A maximum working resistance of 350  $\Omega$  must not be exceeded! In situations where interferences might occur and where very long cables are used (approx. 20m) a screened cable should be used if possible

Example Reagent TH 2100. 0 - 20 mA

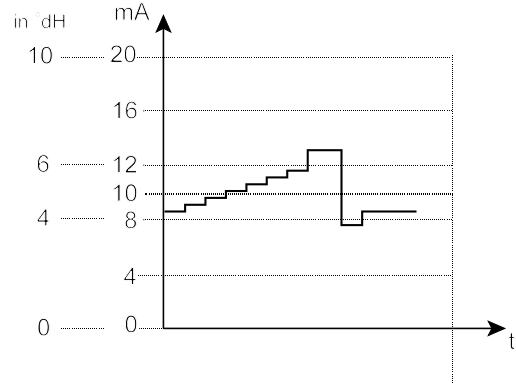

## Structure of menu



## Selection and input

### Start menu

Select one of the two menus by pressing the "M" or the "i" key.

### Selection

The active line position is displayed in CAPITALS. Using the "ENTER" key, the line is activated to enter a submenu. Using the arrow key "V", the next parameter appears below the lowest display line: in this way you scroll the menu.

### Entry function (only possible in the "M" menu)

- You select a programming step by means of the arrow keys "V" and "^" and activate the entry function by pressing the "ENTER" key.
- In the case of digits to be entered, the first digit to be modified flashes.
- You can change the value using the arrow keys "V" and "^".
- By pressing the arrow keys ">" and "<", you confirm the entry and simultaneously change to the next or the preceding digit (which then starts flashing).
- You terminate the entry function by pressing "ENTER".
- The following line is activated.
- By pressing the "M" key you change to the menu one level up.

### End menu

By pressing the "M" or the "i" key you return to the menu one level up. After returning from the highest menu level the unit is again in the display mode.

# Information Menu "i"

## Structure of the "i" menu

You can use the information menu to call up the active settings and status of the unit.

### Call (1)

You call up the information menu "i" by pressing the "i" key.

### Operating values (3)

Display of current values  
Reagent level  
Softwareversion

### Program values (4)

By pressing the arrow keys you can call up the menu item "Program values". By pressing "ENTER" you open the list with the set values. The active setting of a parameter can be queried by pressing "ENTER":  
For example (4a):

"i" → INFORMATION → PROGRAM VALUES → TYPE OF REAGENT

The selected function is marked by a star (in this context there are no active lines).

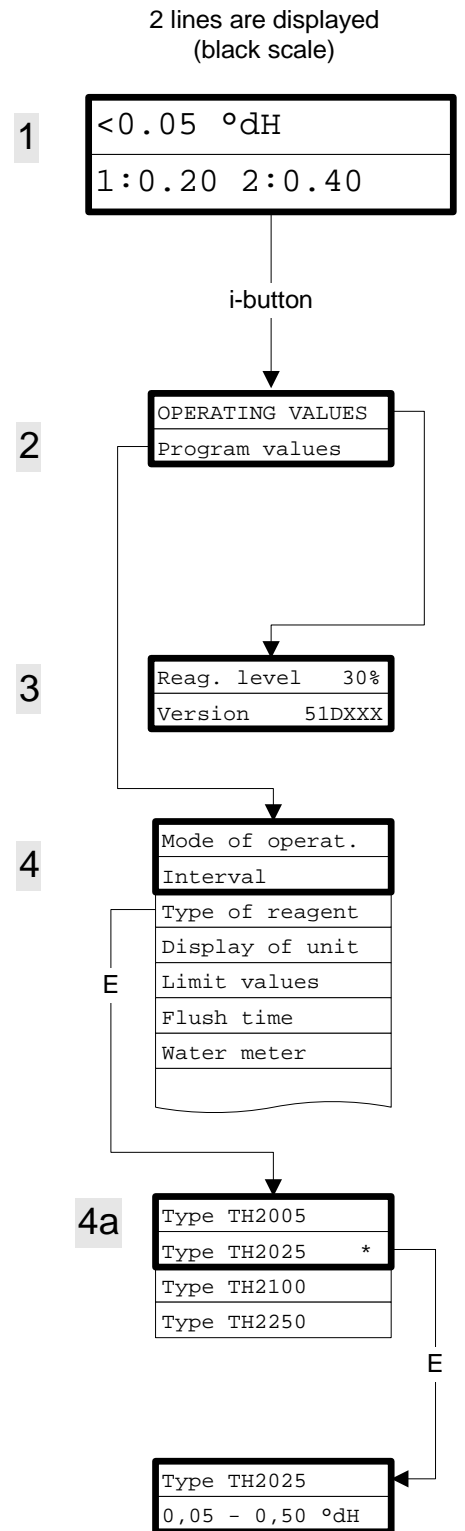

## Program Menu "M"

### Call (1)

By pressing the "M" key the program menu "M" is selected.

Except for the basic programming, you can call up all functions without pass word protection.

### Service I (2)

#### Input Reagent (3)

After **every** refill or replacement of the reagent bottle or of the reagent type, you have to enter the new level. As soon as the menu item for the filling level "INPUT REAGENT (0 - 100%)" has been selected by pressing "ENTER", the value is preset to 100%. If only a partially filled bottle is connected, enter the corresponding % value. When you have connected a full bottle, confirm this value by pressing "ENTER".

#### Manual operation (4)

After you have confirmed the information message (4) by pressing ENTER, you can select the desired function using the arrow keys and then activate them by pressing "ENTER".

These functions are only used for monitoring the operation and for commissioning.

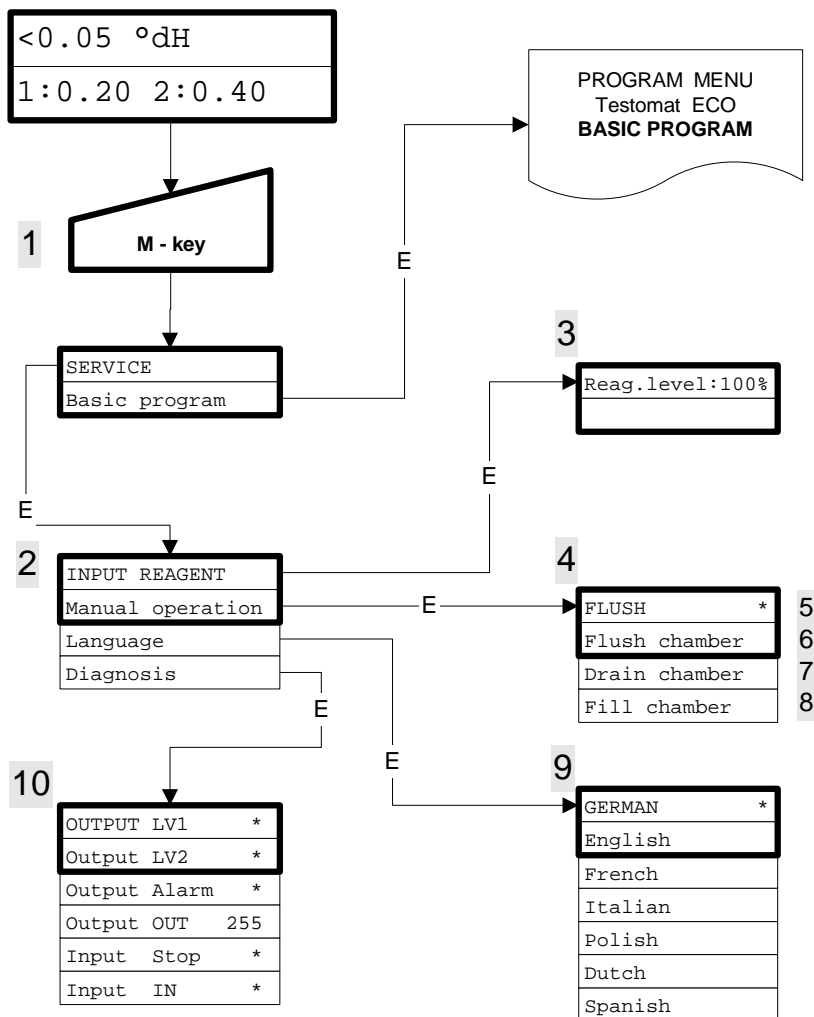

🔒 All manual functions can only be selected during an interval between two analyses. During manual operation, no analysis is carried out.  
All signal inputs and outputs are locked.

### Flush (5)

Start the flushing of the sampling tube through the internal valve by pressing "ENTER". When "ENTER" is pressed again, this function is terminated.

### Flush chamber (6)

By pressing "ENTER", the measuring chamber is flushed once.

### Drain chamber (7)

By pressing "ENTER" you open the outlet valve to drain the water from the measuring chamber. By pressing the "ENTER" key again, this function is terminated.

### Fill chamber (8)

When "ENTER" is pressed, the measuring chamber is filled.

### Language (9)

Chose language of display.

### Diagnosis (10)

You can call up the current status of the signal inputs and outputs from a list. An active status is marked with a \* (see menu structure).  
The value of the output OUT corresponds to 1/10 mA (e. g. 150 = 15.0mA).

# BASIC PROGRAM

After you have entered the menu with "ENTER", you can carry out the BASIC PROGRAMMING of the unit.

## PROGRAM VALUES

To call up the factory-set basic default setting, briefly hold down the "M" and "i" key while switching the unit "ON". Values and settings are described in the structure of the basic program.

## Structure of the BASIC PROGRAMMING

Abbreviations: s = seconds, m = minutes, h = hours, d = days, l = litres

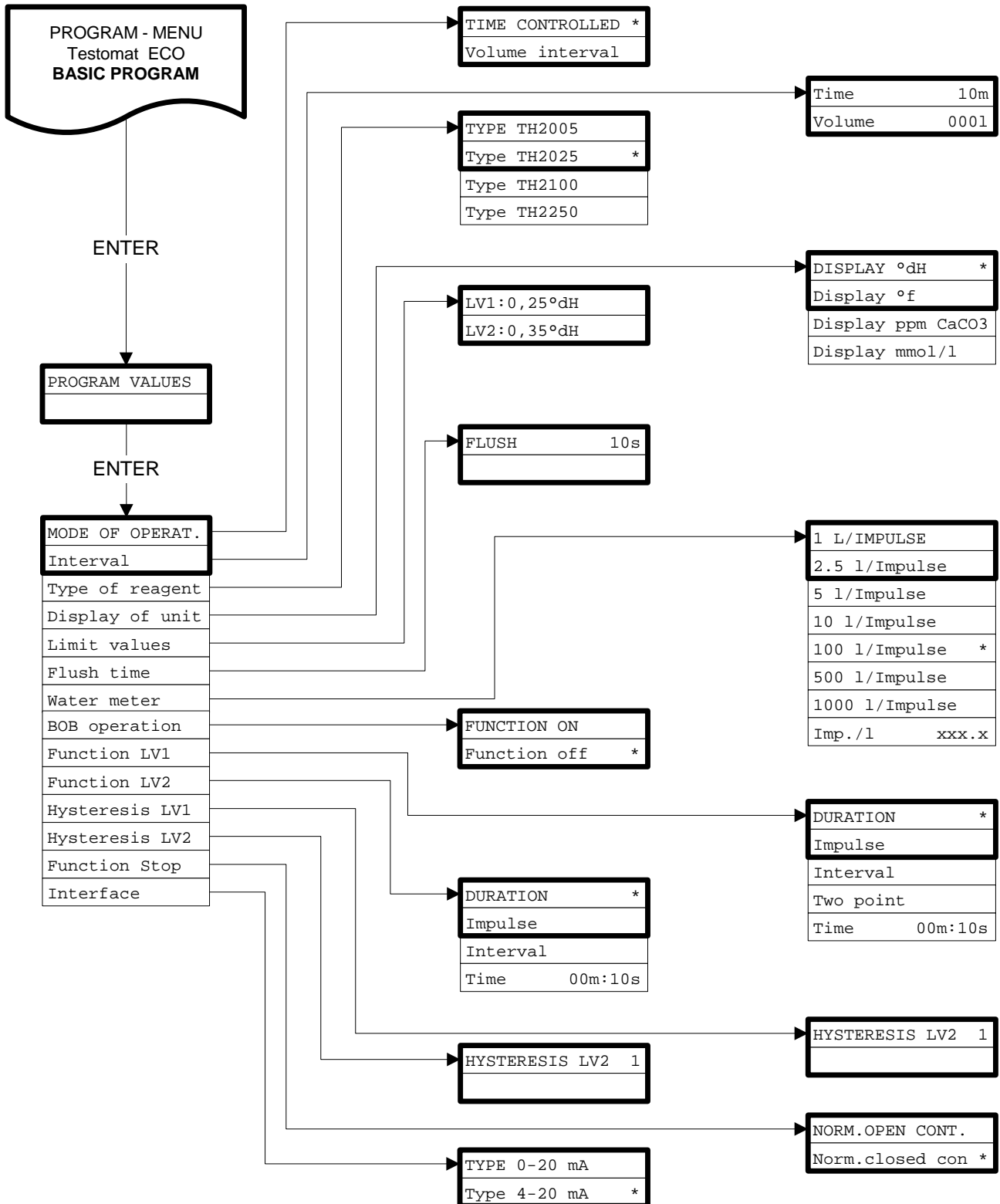

To call up the factory-set basic default setting, briefly hold down the "M" and "i" key while switching the unit "ON". CAUTION the last set of programming will be erased!

## Error Messages / Trouble Shooting

| Displayed Message<br>(flashes at selected display) | Unit result functions                                                                                                    | Possible causes                                                                                                                                                                                         | Remedies                                                                                                                                                                               |
|----------------------------------------------------|--------------------------------------------------------------------------------------------------------------------------|---------------------------------------------------------------------------------------------------------------------------------------------------------------------------------------------------------|----------------------------------------------------------------------------------------------------------------------------------------------------------------------------------------|
| Ff. DOSING PUMP<br>CANCEL WITH HORN-KEY            | <ul style="list-style-type: none"> <li>- After programming: Continuous alarm</li> <li>- Standby</li> </ul>               | <ul style="list-style-type: none"> <li>• Dosing pump defective</li> <li>• No dosing message from the dosing pump</li> </ul>                                                                             | <p>Replace dosing pump<br/>Check cable to the dosing pump for correct connection</p>                                                                                                   |
| Mf. TURBID<br>CANCEL WITH HORN-KEY                 | <ul style="list-style-type: none"> <li>- After programming: Continuous alarm</li> <li>- Continue measurements</li> </ul> | <ul style="list-style-type: none"> <li>• The water is turbid / dirty</li> </ul>                                                                                                                         |                                                                                                                                                                                        |
| MEASURING RANGE EXCEEDED<br>CANCEL WITH HORN-KEY   | <ul style="list-style-type: none"> <li>- After programming: Continuous alarm</li> <li>- Continue measurements</li> </ul> | <ul style="list-style-type: none"> <li>• The measuring range is exceeded</li> </ul>                                                                                                                     | <p>Choose another type of reagent (Basic program)</p>                                                                                                                                  |
| LOW WATER-PRESSURE<br>CANCEL WITH HORN-KEY         | <ul style="list-style-type: none"> <li>- After programming: Continuous alarm</li> <li>- Standby</li> </ul>               | <ul style="list-style-type: none"> <li>• No water input although LED "IN" lights up</li> <li>• Inlet pressure too low</li> <li>• Overflow reagent is not active</li> </ul>                              | <p>Check water inlet<br/>Connector of the inlet valve oxidised<br/>Clean filter strainer<br/>Replace valve block<br/>Extract pressure regulator valve<br/>Carry out adjustment</p>     |
| Ff. OUTLET TO DRAIN<br>CANCEL WITH HORN-KEY        | <ul style="list-style-type: none"> <li>- After programming: Continuous alarm</li> <li>- Standby</li> </ul>               | <ul style="list-style-type: none"> <li>• Water remains in the measuring chamber although LED "OUT" lights up</li> </ul>                                                                                 | <p>Check water outlet<br/>Connector of the outlet valve oxidised<br/>Replace valve block</p>                                                                                           |
| REAGENT LOW<br>CANCEL WITH HORN-KEY                | <ul style="list-style-type: none"> <li>- After programming: Continuous alarm</li> <li>- Continue measurements</li> </ul> | <ul style="list-style-type: none"> <li>• Reagent quantity is below minimum setting without BOB: 50 ml (10 %), with BOB: after calculation!</li> </ul>                                                   | <p>Check reagent level, fill up if necessary<br/>(enter level: "M" → SERVICE)</p>                                                                                                      |
| Mf. DIRTINESS<br>CANCEL WITH HORN-KEY              | <ul style="list-style-type: none"> <li>- After programming: Continuous alarm</li> <li>- Continue measurements</li> </ul> | <ul style="list-style-type: none"> <li>• Sight-glass windows dirty</li> </ul>                                                                                                                           | <p>Clean sight-glass windows</p>                                                                                                                                                       |
| Ff. OPTICS<br>CANCEL WITH HORN-KEY                 | <ul style="list-style-type: none"> <li>- After programming: Continuous alarm</li> <li>- Standby</li> </ul>               | <ul style="list-style-type: none"> <li>• Plug-in circuit board defective</li> <li>• Error at the optic component (Transmitter or Receiver defective)</li> </ul>                                         | <p>Replace plug-in circuit board<br/>Replace measuring chamber sealing rings</p>                                                                                                       |
| Mf. ANALYSIS<br>CANCEL WITH HORN-KEY               | <ul style="list-style-type: none"> <li>- After programming: Continuous alarm</li> <li>- Standby</li> </ul>               | <p>Incorrect analysis, e.g:</p> <ul style="list-style-type: none"> <li>• Air in the dosing capillary</li> <li>• incomplete blending</li> <li>• Reagent too old or use of third-party reagent</li> </ul> | <p>Tighten connections of the dosing pump<br/>Replace stirring mechanism<br/>Replace suction insert in the bottle<br/>Replace reagent, only use <b>HEYL Testomat® 2000 reagent</b></p> |
| Ff. DOSING FAULT<br>CANCEL WITH HORN-KEY           | <ul style="list-style-type: none"> <li>- After programming: Continuous alarm</li> <li>- Continue measurements</li> </ul> | <ul style="list-style-type: none"> <li>• Dosing inaccuracy of the dosing pump</li> </ul>                                                                                                                | <p>Replace dosing pump or return to the supplier for calibration</p>                                                                                                                   |

Ff. = Function fault

Mf. = Measuring fault

## Further Information

| Fault                                        | Possible causes                                                                                                                                                                                                                                                                             | Remedies                                                                                                                                                                          |
|----------------------------------------------|---------------------------------------------------------------------------------------------------------------------------------------------------------------------------------------------------------------------------------------------------------------------------------------------|-----------------------------------------------------------------------------------------------------------------------------------------------------------------------------------|
| Interface works incorrectly                  | <ul style="list-style-type: none"> <li>• incorrect measuring value at the output or no power supply</li> </ul>                                                                                                                                                                              | <ul style="list-style-type: none"> <li>– Max. load exceeded</li> </ul>                                                                                                            |
| Although unit is switched "ON"<br>No display | <ul style="list-style-type: none"> <li>• Fuse F9, F5 or F2 (240 V: F1) defective</li> <li>• Power switch defective</li> <li>• Multi-pin strap cable at display circuit board or base circuit board loose contact</li> <li>• Fault on display circuit board or base circuit board</li> </ul> | <ul style="list-style-type: none"> <li>– Replace fuses</li> <li>– Replace power switch</li> <li>– Check and reconnect</li> <li>– Replace display or base circuit board</li> </ul> |

## Maintenance

### Regular maintenance is necessary in order to ensure trouble-free operation of the unit!

Please carry out the maintenance work described in the following section when

- the programmed maintenance date has been reached (display "maintenance date exceeded")
- the unit displays the following error messages: "Mf.dirtiness" or "Reagent low level"
- the last maintenance was carried out more than 6 months ago

 Never use organic solvents to clean the measuring chamber and other plastic parts!  
Please observe the safety rules when handling cleaning agents!

 If the measuring range has been exceeded over an extended period, a coloured coating can form on the sight-glass windows. This stubborn coating can be easily removed with alcohol.

## Description of maintenance work

### Cleaning the measuring chamber and the sight-glass windows

1. Switch the unit 'off' or press the "STANDBY" key (drain measuring chamber completely !).
2. Close the hand-operated valve on the branch line to the TESTOMAT® ECO.
3. Unhook toggle type fastener, tip the measuring chamber upwards and extract.
4. Slacken both sight-glass window holders, extract and clean the sight-glass windows.
5. This stubborn coating can be easily removed with alcohol.
6. Clean the measuring chamber with 10% hydrochloric acid and then rinse well.
7. After cleaning, replace the sight-glass windows and secure these with the sight-glass windows holder (do not forget the O-ring seals and check for correct seating in the recess).
8. Insert the measuring chamber by tilting it backwards until the slot engages with the rear guide bar and press down. Finally secure the chamber with the toggle type fastener.



### Cleaning the filter housing

1. Close the hand-operated valve on the branch line to the TESTOMAT® ECO.
2. Undo the hose connections to the filter housing.
3. Unscrew inlet connection remove sealing ring, spring and filter strainer and clean.
4. Extract the retaining pin and withdraw the flow regulator and finally remove the valve body.
5. Clean filter housing with water or alcohol and and reassemble.  
Insert filter strainer point downwards!
6. Install the hose connections to the filter housing.

 Water Leakage from of the seals can result in damage to parts of the unit

- ✓Tip: Please check the unit for leaks before carrying out the first analysis
- switch the unit to STANDBY
  - manually fill the measuring chamber
  - manual reagent dosing (key "Manual")
  - check the connections and seals for leaks

## Note on care for the unit

The surface of the unit has not been treated. Therefore, a contamination with reagent, oil or grease should be avoided. Should the housing, however, be contaminated, please clean the surface with isopropanol (never use other solvents).

## SPARE PARTS LIST Testomat® ECO

| Item No.                            | Pressure regulator                                  |
|-------------------------------------|-----------------------------------------------------|
| 40120                               | Regulator / filter housing                          |
| 40129                               | Regulator plug T2000, kpl.                          |
| 11225                               | Flow regulator valve (1 - 8 bar)                    |
| 11230                               | Retaining pin for regulator plug                    |
| 11217                               | Inlet filter                                        |
| 11218                               | Spring for inlet filter                             |
| 40121                               | Inlet connector                                     |
| 40153                               | Plug in connector - G 1/4" -6                       |
| Measuring chamber                   |                                                     |
| 40173                               | Sight-glass window 30 x 3 with seal                 |
| 40170                               | Sight-glass window 30 x 3                           |
| 40176                               | Sight-glass retaining disc                          |
| 33253                               | Screw spindle M3x40                                 |
| 40032                               | Latch fastener TL 800-7-1                           |
| 11203                               | Plastic plug                                        |
| 40022                               | Measuring chamber T2000                             |
| Holding block for measuring chamber |                                                     |
| 40029                               | Holding block complete (without solenoid valve)     |
| 40050                               | Magnetic stirrer                                    |
| 40186                               | Plug in connector -G 3/8" -10                       |
| 40056                               | Solenoid valve, 2/2-Way                             |
| 40181                               | Rear guide bar for measuring chamber 5 x 60         |
| Dosing pump DOSIClip®               |                                                     |
| 40001                               | Jet pump complete, complete                         |
| 40011                               | Suction capillary complete                          |
| 40016                               | Pressure capillary complete                         |
| 40040                               | Valve-set                                           |
| 37232                               | Base circuit board TI, complete                     |
| 34668                               | Magnet 24 VDC                                       |
| 32046                               | Plastic cover CNH 45 N                              |
| Bottle connection/Suction tube      |                                                     |
| 40131                               | Screwed cap with bottle insert T2000                |
| 40130                               | Screwed cap GL32 - only                             |
| 40135                               | Bottle insert for screwed cap with push-fit suction |

| Item No                                             | Electrical components                               |     |
|-----------------------------------------------------|-----------------------------------------------------|-----|
| 31582                                               | Fuse M4A                                            |     |
| 37245                                               | Base circuit board T-ECO, complete 230V             |     |
| 40192                                               | Control circuit board T-ECO, complete.              |     |
| 40071                                               | EPROM T-ECO                                         |     |
| 40190                                               | Cable sleeve 5 -7                                   |     |
| 40191                                               | Cable sleeve 7 -10                                  |     |
| 40197                                               | Mains on / off switch Testomat 2000                 |     |
| 40198                                               | Cover for Mains on / off switch                     |     |
| 31713                                               | Multi-pin strap cable 10 pol. with EMI filter clamp |     |
| 40096                                               | Multi-pin strap cable 26 pol. with EMI filter clamp |     |
| 40060                                               | Cable loom 2V complete (for valves)                 |     |
| 40062                                               | Cable loom 2P complete (for max. 2 dosing pumps)    |     |
| 40200                                               | Cable loom for Mains on / off switch complete       |     |
| 31622                                               | Fuse T0,16A                                         |     |
| 31592                                               | Fuse T1,0A                                          |     |
| Spare parts requirement for 2 -3 years of operation |                                                     |     |
| 40173                                               | Sight-glass window 30 x 3 with seal                 | 2 x |
| 11217                                               | Inlet filter                                        | 1 x |
| 40124                                               | Gasket set T2000 (after maintenance)                | X*  |
| 31622                                               | Fuse T0,16A                                         | 1   |
| 31592                                               | Fuse T1,0A                                          | 1   |

X\* Accurate operation of the TESTOMAT® ECO can be assured only with regular maintenance and replacements of seals / gaskets (see text on maintenance).

### Accessories:

#### Order no.

- 040123 Optional adapter for water inlet (Quick-acting plug and -coupling).
- 040127 Additional set pressure regulator (Regulator / filter housing with tube )

### Reagents:

#### Order no.

|        |        |                                                  |
|--------|--------|--------------------------------------------------|
| 152005 | TH2005 | Water hardness 0.89 - 8.93 ppm CaCO <sub>3</sub> |
| 152025 | TH2025 | Water hardness 4.47 - 44.7 ppm CaCO <sub>3</sub> |
| 152100 | TH2100 | Water hardness 17.9 - 179 ppm CaCO <sub>3</sub>  |
| 152250 | TH2250 | Water hardness 44.8 - 448 ppm CaCO <sub>3</sub>  |

# Technical Appendix

## Block diagram Testomat® ECO

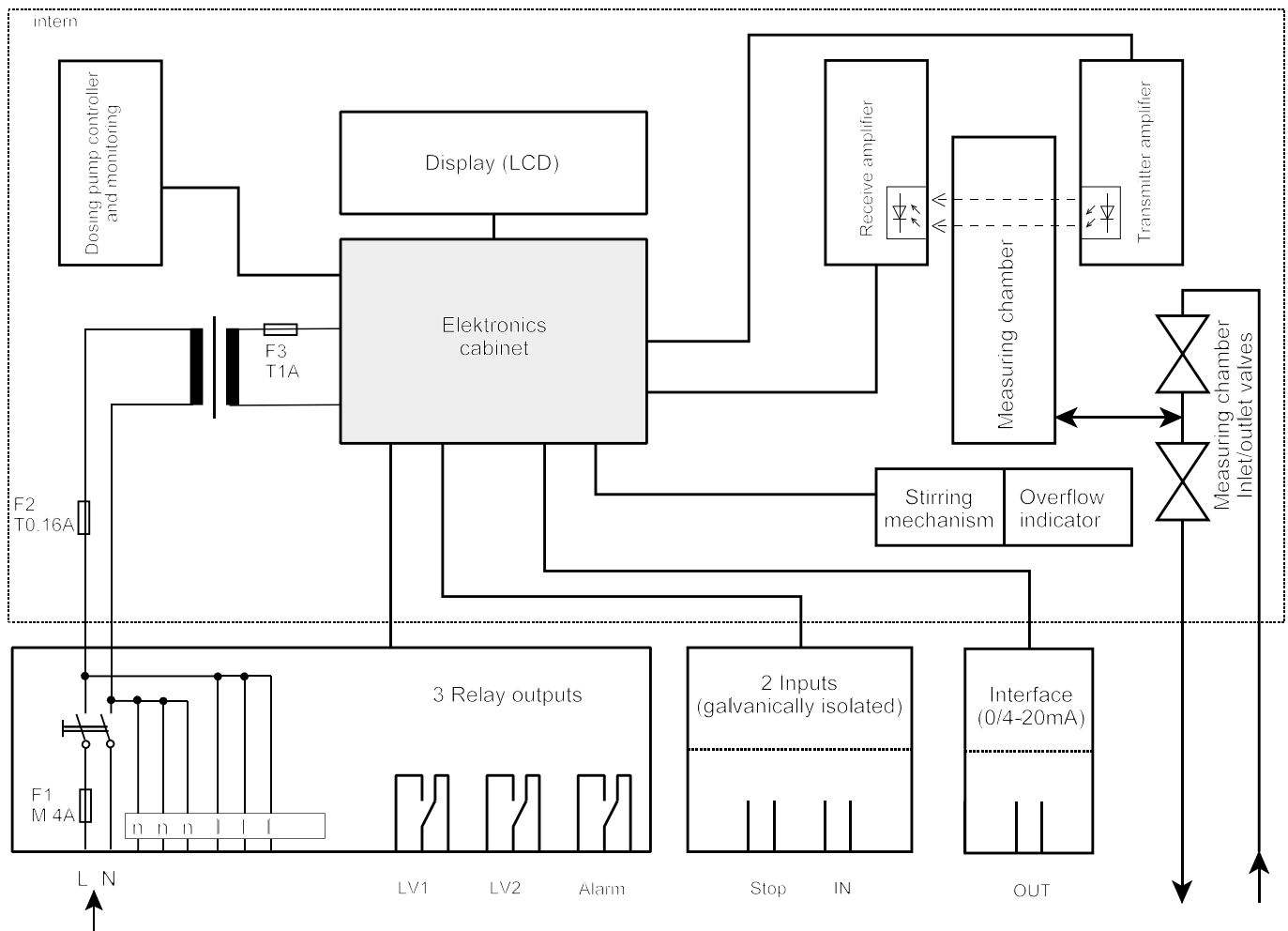

### Technical data

**Power supply:** 230 V or 24 V  $\pm$  10 %, 50 - 60 Hz, fuse M4A  
**Unit protection:** 230 V: M0.16A  
 24 V: T1.0A

**Power consumption:** max. 30VA  
**Degree of protection:** IP 65  
**Protection class:** I  
**Conformity:** EN50081-1, EN50082-2, EN 61010-1  
**Ambient temperature:** 10 - 45 °C  
**Contact rating of the relay outputs:** 4 A resistive load, fuse M4A  
**Measuring range:** see page 1  
**Interface:** 0/4 - 20 mA, max. load 350 Ohm  
**Water supply:** 0.3 - 8 bar  
**Water temperature:** max. 40 °C  
**Dimensions (W x H x D):** 380 x 480 x 280 mm  
**Weight:** approx. 9 kg



We reserve the right to make technical changes without notice in the interest of constantly improving our products!