

**GEMU®**

**InterApp IA®**

**DESPONIA**  
Butterfly valve DN25-1400

Large choice of materials  
for most of the industrial applications





[www.interapp.net](http://www.interapp.net)

**FLUIDS UNDER CONTROL**

DESPONIA\_0811

## DESPONIA Butterfly valve DN25-1400

### ● Characteristics:

<b>DESPONIA</b>	Centric butterfly valve with elastomer liner		
<b>Application fields</b>	For liquids and gases in the industrial range, general services, water treatment, ...		
<b>Body construction</b>	<b>D1</b> Wafer DN 25-800	<b>D3</b> LUG DN 25-400	<b>D4</b> U-section DN 150-1400
			
<b>Face to face dimension</b>	according to ISO 5752/20, EN 558-1/20		
<b>Top flange</b>	according to EN ISO 5211		
<b>Max. working pressure</b>	16 bar		
<b>Rating</b>	PN6, PN10, PN16, ANSI cl. 150		
<b>Temperature range</b>	Standard -10°C ÷ 95°C with EPDM liner, max. -10°C ÷ 200°C according to material, other temperatures on request		
<b>Tightness test</b>	according to EN 12266-1/P12 leakage rate A, test fluid water		
<b>CE</b>	The butterfly valves DESPONIA meet the safety requirements of the pressure Equipments Directive 97/23/EC (PED) appendix 1 for fluids of the groups 1 and 2.		

### ● Construction:

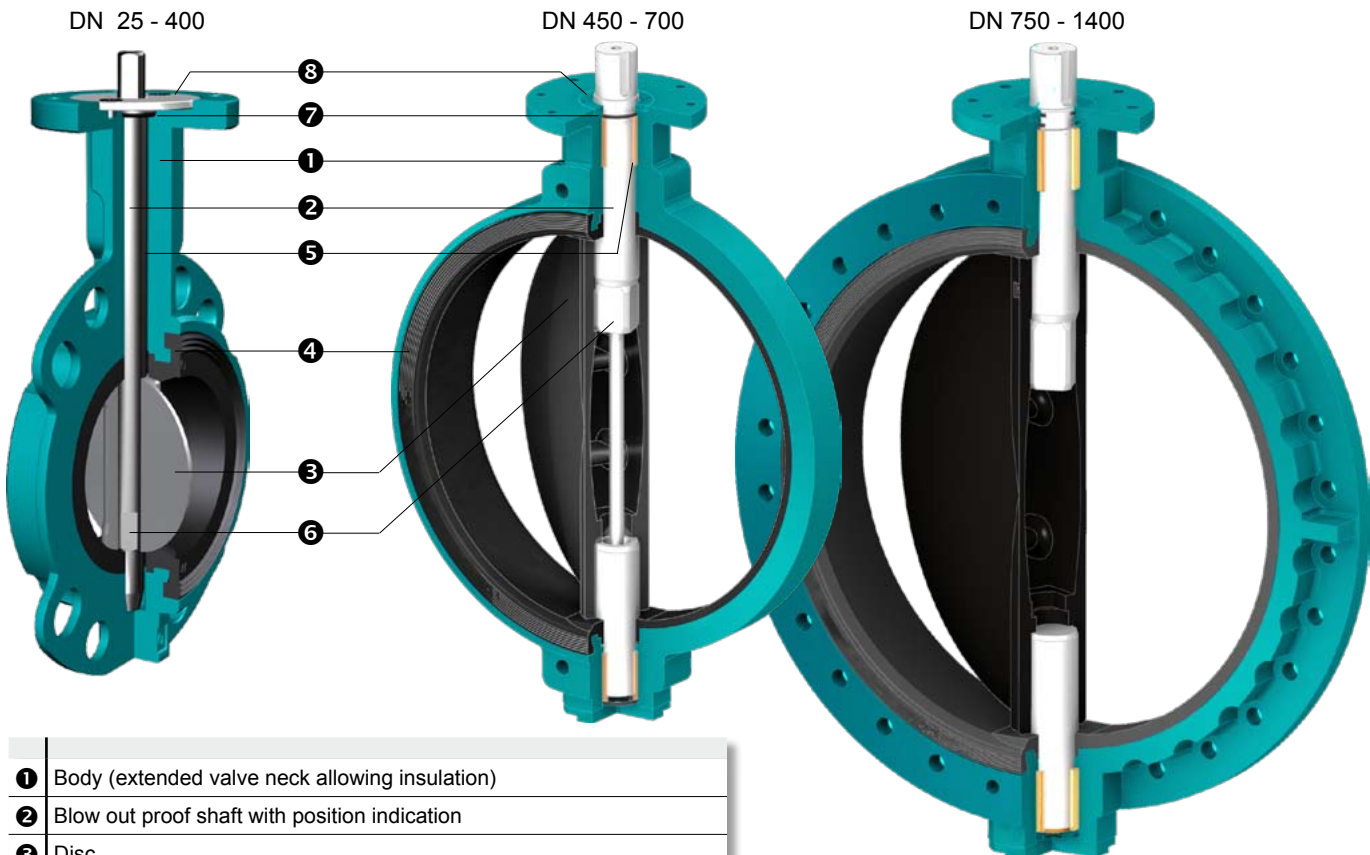

<b>1</b>	Body (extended valve neck allowing insulation)
<b>2</b>	Blow out proof shaft with position indication
<b>3</b>	Disc
<b>4</b>	Exchangeable liner with sealing grooves on the tightening face
<b>5</b>	Shaft bearing (DN25-400 rilsan, DN450-1400 bronze)
<b>6</b>	Square driven disc
<b>7</b>	External shaft sealing
<b>8</b>	Retaining washer (blow out protection)

## DESPONIA Butterfly valve DN25-1400

• Code key:

**D1** **0100** . **33** - **2AR** . **4A** . **2AR** . **E**



①      ②      ③④      ⑤      ⑥      ⑦      ⑧

① Body type	D1	Wafer	DN25-800						
	D3	LUG body	DN25-400						
	D4	U-section body	DN150-1400						
② Nominal diameter	0025-1400 mm								
③ Working pressure	1	6 bar (special execution with reduced disc diameter)							
	*	10/16 bar, see table below							
④ Rating	**	PN6/10/16 see table below. Other ratings on request							
⑤ Body	1AR	Cast iron GG25, Epoxy (Resicoat®) coated 200µ	DN250-400						
	1AE	Cast iron GG25, Polyurethan coated 70µ	DN450-1400						
	2AR	Ductile iron GGG40, Epoxy (Resicoat®) coated 200µ	DN25-400						
	2AE	Ductile iron GGG40, Polyurethan coated 70µ	DN450-1400						
⑥ Shaft	4A	Stainless steel 1.4028, AISI420							
	4L	Stainless steel 1.4542 / 17-4PH							
⑦ Disc	2AR	Ductile iron GGG40, Rilsan coated 250µ (max.90°C)	DN25-700						
	2AE	Ductile iron GGG40, Epoxy coated 70µ	DN800-1400						
	2AC	Ductile iron GGG40, Chrome coated							
	4C0	Stainless steel 1.4408, AISI316							
	4CP	Stainless steel 1.4408, AISI316, polished							
	4CH	Stainless steel 1.4408, AISI316, Halar coated min.600µ							
	4D0	Uranus B6							
	5C0	Alubronze G-Cu Al 10 Ni / 2.0976 / C95800 / ASTM B148-958							
7H0	Hastelloy C								
⑧ Liner	E	EPDM (max.95°C)	N	Nitrile (NBR)	B	Butyl	SV	Silicone for steam	
	EA	EPDM ACS FDA (max.130°C)	NC	Nitrile carboxylit	H	CSM	SA	Silicone for food industry	
			RN	Natural rubber	S	Silicone	V	FKM	
	Other materials and white liners on request								

\* Working pressure (Code)

Body material	DN→	25	32	40	50	65	80	100	125	150	200	250	300	350	400	450	500	600	700	800	900	1000	1200	1400	
GG25 (1A)	10 bar																								
GGG40 (2A)	10 bar																								
	16 bar																								

\*\*Rating (Code)

DESPONIA	DN→	25	32	40	50	65	80	100	125	150	200	250	300	350	400	450	500	600	700	800	900	1000	1200	1400	
 D1	PN6																								
	PN10																								
	PN16																								
 D3	PN10																								
	PN16																								
 D4	PN10																								
	PN16																								

When mounting the valve at the end of a line please note:

- Body type: D3 possible without counter flange, D4 only with counter flange
- Body material: 2A (GGG40) only for liquids, 10+30°C
- Medium: DN25-200 10 bar, DN250-600 6 bar, DN700-1400 2,5 bar
- Max. working pressure
- no water hammer !!!

please consult our document "Flanges"

Other executions on request !



Pressure and temperature limits of application are dependent of the working conditions.

**FLUIDS UNDER CONTROL**

## DESPONIA Butterfly valve DN25-1400

● Kv values m³/h

DN	25/32	40	50	65	80	100	125	150	200	250	300	350	400	450	500	600	700	800	900	1000	1200	1400
kv	40	50	100	210	360	650	1050	1770	3400	5090	7360	9800	12900	16800	21700	29800	35100	45900	59300	82100	102700	≈170000

● D1 Wafer, DN 25-800

DN 25/32



DN 40/50/65



DN 80/100



DN 125/150/200

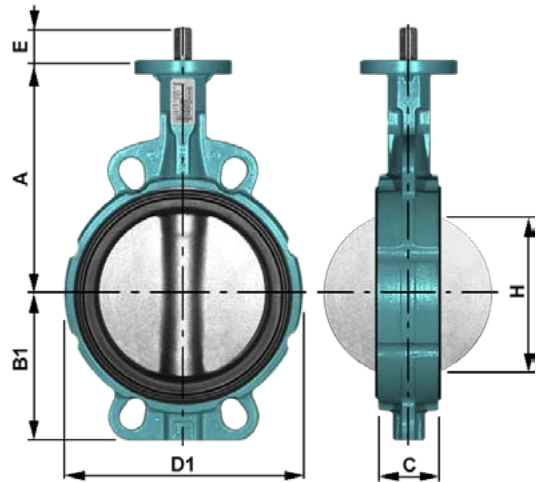

DN 250-400



DN 450-800



DN	A	B1	C	D1	E	H*	[kg]
25/32	110	50	30	72	19	17,0	1,4
40	130	60	33	86	19	27,0	2,0
50	135	72	43	101	19	30,0	3,0
65	150	82	46	121	19	49,0	3,6
80	160	92	46	138	19	68,5	4,0
100	180	102	52	160	19	88,5	5,5
125	195	120	56	189	19	114,5	7,5
150	210	133	56	214	19	142,0	8,6
200	240	163	60	272	25	193,5	12,7
250	280	196	68	324	32	243,5	22,2
300	315	232	78	378	32	292,5	30,8
350	330	257	78	425	40	329,5	41,5
400	365	292	102	475	40	375,5	57,2
450	400	359	114	538	65	426	95,0
500	440	397	127	595	65	477	125
600	525	467	154	695	80	572	180
700	565	518	165	800	80	663	280
800	632	562	190	908	80	780	387

\* When using plastic stubs please check dimension H to avoid damaging of disc

**DESPONIA** Butterfly valve DN25-1400

● **D3 LUG body, DN 25-400**

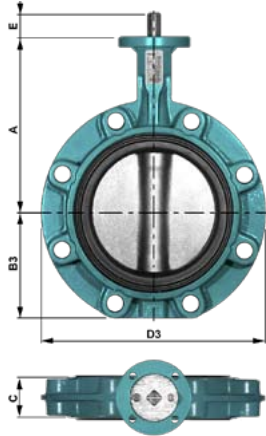

DN	A	B3	C	D3	E	H*	[kg]
25/32	110	50	30	72	19	17,0	1,4
40	130	60	33	86	19	27,0	2,0
50	135	72	43	117	19	30,0	3,2
65	150	82	46	130	19	49,0	4,0
80	160	88	46	188	19	68,5	6,1
100	180	102	52	219	19	88,5	8,5
125	195	116	56	248	19	114,5	10,0
150	210	128	56	274	19	142,0	11,0
200	240	161	60	332	25	193,5	19,6
250	280	199	68	402	32	243,5	28,7
300	315	234	78	472	32	292,5	41,2
350	330	258	78	520	40	329,5	55,0
400	365	290	102	584	40	375,5	75,0

● **D4 U-section body, DN 150-1400**

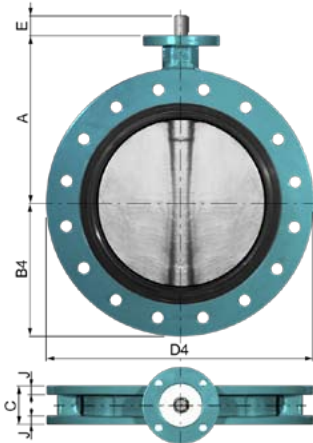

DN	A	B4	C	D4	H*	J	E	[kg]
150	210	143	56	285	142,0	10,0	19	15,0
200	240	170	60	340	193,5	12,5	25	19,5
250	280	200	68	406	243,5	15,0	32	30,5
300	315	239	78	482	292,5	15,0	32	44,0
350	330	265	78	533	329,5	18,0	40	59,0
400	365	296	102	596	375,5	20,0	40	82,0
450	400	359	114	640	426	24,0	65	118
500	440	397	127	715	477	26,0	65	175
600	525	467	154	840	572	28,5	80	260
700	565	503	165	927	663	31,5	80	345
(750)	590	541	170	985	712	34,0	80	435
800	630	580	190	1060	780	36,5	80	510
900	695	650	203	1170	855	38,0	100	660
1000	748	696	216	1255	960	44,0	100	790
(1100)	768	738	218	1340	1055	44,0	100	850
1200	882	809	254	1485	1150	47,0	120	1180
1400	990	938	280	1680	1340	40,0	120	1700

● **Top flange according to ISO 5211**

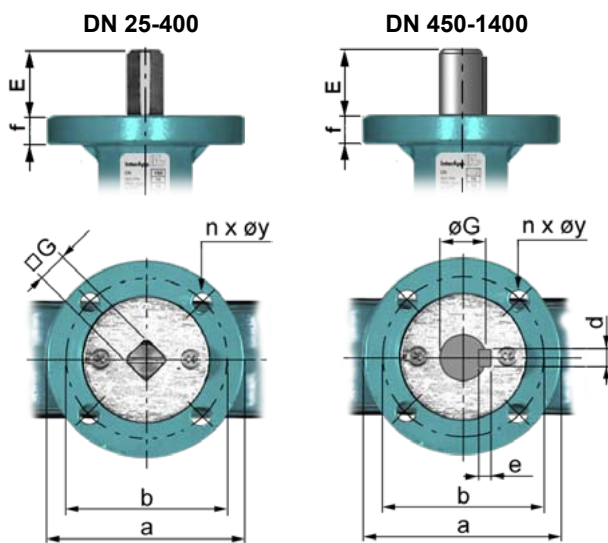

DN	E	G	d	e	f	ISO	a	b	n x øy
25/32	19	□ 8	-	-	12	F07	90	70	4 x 9
40	19	□ 8	-	-	12	F07	90	70	4 x 9
50	19	□ 11	-	-	12	F07	90	70	4 x 9
65	19	□ 11	-	-	12	F07	90	70	4 x 9
80	19	□ 11	-	-	12	F07	90	70	4 x 9
100	19	□ 11	-	-	12	F07	90	70	4 x 9
125	19	□ 14	-	-	12	F07	90	70	4 x 9
150	19	□ 14	-	-	12	F07	90	70	4 x 9
200	25	□ 17	-	-	12	F07	90	70	4 x 9
250	32	□ 22	-	-	18	F10/F12	155	102/125	4 x 10 / 4 x 13
300	32	□ 22	-	-	18	F10/F12	155	102/125	4 x 10 / 4 x 13
350	40	□ 22	-	-	18	F12	155	125	4 x 13
400	40	□ 27	-	-	18	F12	155	125	4 x 13
450	65	ø 45	14	9	25	F14	175	140	4 x 18
500	65	ø 45	14	9	25	F14	175	140	4 x 18
600	80	ø 70	20	12	25	F16	220	165	4 x 22
700	80	ø 70	20	12	25	F25	300	254	8 x 18
(750)	80	ø 70	20	12	30	F25	300	254	8 x 18
800	80	ø 70	20	12	30	F25	300	254	8 x 18
900	100	ø 80	22	14	30	F30	350	298	8 x 22
1000	100	ø 80	22	14	30	F30	350	298	8 x 22
(1100)	100	ø 80	22	14	30	F30	350	298	8 x 22
1200	120	ø 100	28	16	30	F30	350	298	8 x 22
1400	120	ø 120	32	18	35	F30	350	298	8 x 22

**DESPONIA** Butterfly valve DN25-1400

● **Handlever (DN25-300):**

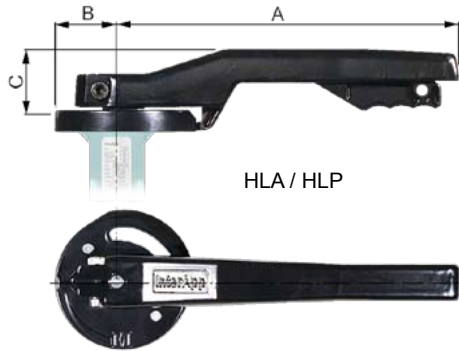

Aluminium, Epoxy coated

DN		A	B	C	(kg)
25-40	<b>HLA.F0708.180</b>	180	45,5	41	0,4
50-65	<b>HLA.F0711.180</b>	180	45,5	41	0,4
80-100	<b>HLA.F0711.240</b>	243	45,5	43	0,5
125-150	<b>HLA.F0714.340</b>	340	45,5	51	0,6
200	<b>HLA.F0717.340</b>	340	45,5	51	0,6
250-300	<b>HLA.F1222.500</b>	500	77,5	40	2,2

Polyamide PA 6, 30% glass fibers reinforced

DN		A	B	C	(kg)
25-40	<b>HLP.F0708.240</b>	243	45,5	41	0,3
50-65	<b>HLP.F0711.240</b>	243	45,5	41	0,3
80-100	<b>HLP.F0711.240</b>	243	45,5	43	0,3
125-150	<b>HLP.F0714.340</b>	340	45,5	51	0,5
200	<b>HLP.F0717.340</b>	340	45,5	51	0,5

● **Plumber square (DN25-200):**

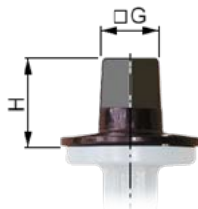

DN		G	H
25-40	<b>PO.F0708.30</b>	30	65
50-100	<b>PO.F0711.30</b>	30	65
125-150	<b>PO.F0714.30</b>	30	65
200	<b>PO.F0717.30</b>	30	65

● **Handwheel (DN25-150):**

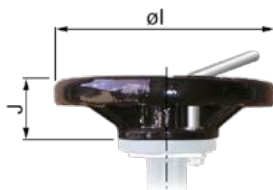

DN		I	J
25-40	<b>HW.F0708.200</b>	200	52
50-100	<b>HW.F0711.200</b>	200	52
125-150	<b>HW.F0714.250</b>	250	52

**DESPONIA** Butterfly valve DN25-1400

● **Gearbox:**

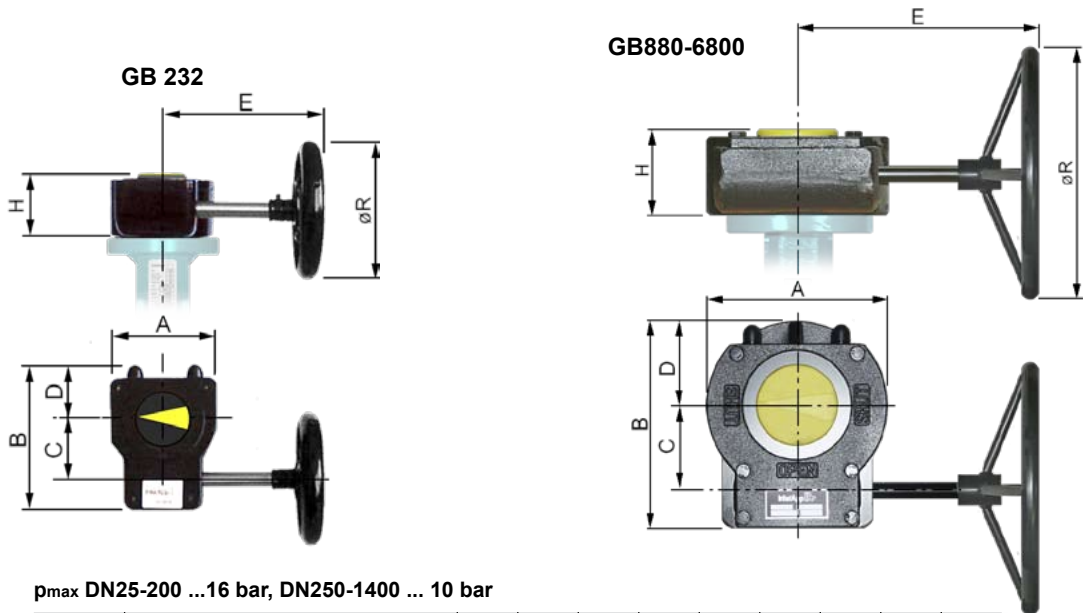

p<sub>max</sub> DN25-200 ... 16 bar, DN250-1400 ... 10 bar

DN		A	B	C	D	E	H	øR	n*	[kg]
25-40	<b>GB232-05.F05-F0711.100(R08)</b>	80	114	42,5	48	121	53	100	10	0,8
50-100	<b>GB232-05.F05-F0711.100</b>	80	114	42,5	48	121	53	100	10	0,8
125-150	<b>GB232-05.F05-F0714.100</b>	80	114	42,5	48	121	53	100	10	0,8
200	<b>GB232-06.F05-F0717.160</b>	80	114	42,5	48	179	59	160	10	0,9
250-300	<b>GB232-08.F07-F1022.250</b>	100	131	50	56	209	67	250	9,25	1,55
350	<b>GB232-13.F10-F1222.300</b>	175	209	80	83	361	84	300	10	5,4
400	<b>GB232-13.F10-F1227.500</b>	175	209	80	83	396	84	500	10	5,4
450	<b>GB232-14.F1445.600</b>	175	209	80	83	396	84	600	10	5,4
500	<b>GB1250N.F1445.500</b>	220	258	105	110	326	100	500	13,75	22
600	<b>GB1250N.F1665.700-SH100</b>	220	258	105	110	446	100	700	13,75	22
700	<b>GB1950N/HR.F2570.600</b>	285	402,5	211	142,5	467	155	600	21	32
750	<b>GB1950N/HR.F2570.600</b>	285	402,5	211	142,5	467	155	600	21	32
800	<b>GB1950N/HR.F2570.700-SH100</b>	285	402,5	211	142,5	487	155	700	21	32
900	<b>GB6800N/SP4.F3080.500</b>	370	482	263	170	500	160	500	79,25	70
1000	<b>GB6800N/SP4.F3080.500</b>	370	482	263	170	500	160	500	79,25	70
1100	<b>GB6800N/SP4.F3080.500</b>	370	482	263	170	500	160	500	79,25	70
1200	<b>GB6800N/SP4.F30100.500</b>	370	482	263	170	500	160	500	79,25	70
1400	<b>GBA250G/SP9.F30120.800</b>	510	725	431	235	629	169	800	176	225

Material:

GB232 : Aluminium, Polyurethan coated  
 GB880-GB6800 : Cast iron, Polyurethan coated

\* n = Handwheel turns ON/OFF

- **Further documentation:**
  - pneumatic actuators
  - electric actuators
  - **Accessories**
 according separate data sheets

- **Important guides:**
  - **Installation guide**
  - **Maintenance guide**
  - **Flanges**

Please consult these guides for the installation and maintenance of our butterfly valves

You can find most of these documents as well as the declaration of conformity and other certificates in several languages at our homepage



## Switzerland

InterApp AG  
Grundstrasse 24  
CH-6343 Rotkreuz

Tel. +41 (0)41 798 22 33  
Fax +41 (0)41 798 22 34  
info@ch.interapp.net



## Austria

InterApp Ges.m.b.H.  
Kolpingstraße 19  
A-1230 Wien

Tel. +43 (0)1 616 23 71 0  
Fax +43 (0)1 616 23 71 99  
info@at.interapp.net



## Italy

InterApp Italiana S.r.l.  
Via A. Gramsci 29  
I-20016 Pero (Milano)

Tel. +39 02 33 93 71  
Fax +39 02 33 93 7200  
info@it.interapp.net



## Spain

InterApp Válvulas S.A.  
Igarsa 40  
E-28860 Paracuellos de Jarama

Tel. +34 (0)91 6584360  
Fax +34 (0)91 6581430  
info@es.interapp.net



## Hungary

InterApp Kft  
Bécsi út 100  
H-1034 Budapest

Tel. +36 (1) 436 9702  
Fax +36 (1) 436 9700  
info@hu.interapp.net



## Germany

GEMÜ Gebr. Müller  
Fritz-Müller-Strasse 6-8  
74653 Ingelfingen-Criesbach

Tel. ++49-7940-12 30  
Fax ++49-7940-12 31 92 (Domestic)  
Fax ++49-7940-12 32 24 (Export)  
e-mail: info@gemue.de

[www.gemue.de](http://www.gemue.de)

The technical data are noncommittal and do not assure you of any properties. Please refer to our general sales conditions.

Modifications without notice

Copyright © by InterApp